

Access Integration Services



# Using and Configuring Features Version 3.4



Access Integration Services



# Using and Configuring Features Version 3.4

**Note**

Before using this document, read the general information under "Notices" on page xxiii.

**Third Edition (October 1999)**

This edition applies to Version 3 Release 4 of the IBM Access Integration Services and to all subsequent releases and modifications until otherwise indicated in new editions or technical newsletters.

Order publications through your IBM representative or the IBM branch office serving your locality. Publications are not stocked at the address below.

IBM welcomes your comments. A form for readers' comments is provided at the back of this publication. If the form has been removed, you may address your comments to:

Department CGF  
Design & Information Development  
IBM Corporation  
P.O. Box 12195  
Research Triangle Park NC 27709  
U.S.A.

If you prefer, you may use the IBM support Web site to submit comments. To do this, click *Overall Site Feedback* at URL:

<http://www.networking.ibm.com>

When you send information to IBM, you grant IBM a non-exclusive right to use or distribute the information in any way it believes appropriate without incurring any obligation to you.

© **Copyright International Business Machines Corporation 1994, 1999. All rights reserved.**

US Government Users Restricted Rights – Use, duplication or disclosure restricted by GSA ADP Schedule Contract with IBM Corp.

---

# Contents

<b>Figures</b> . . . . .	xix
<b>Tables</b> . . . . .	xxi
<b>Notices</b> . . . . .	xxiii
<b>Trademarks</b> . . . . .	xxv
<b>Preface</b> . . . . .	xxvii
Who Should Read This Manual . . . . .	xxvii
Getting Additional Information . . . . .	xxvii
About the Software. . . . .	xxvii
Conventions Used in This Manual . . . . .	xxviii
Library Overview . . . . .	xxviii
Summary of Changes for the IBM 2212 Software Library . . . . .	xxx
Getting Help . . . . .	xxxii
Exiting a Lower Level Environment. . . . .	xxxii
<b>Chapter 1. Using Bandwidth Reservation and Priority Queuing</b> . . . . .	1
Bandwidth Reservation System . . . . .	1
Bandwidth Reservation over Frame Relay . . . . .	3
Queuing Support . . . . .	4
Discard Eligibility. . . . .	4
Default Circuit Definitions for Traffic Class Handling . . . . .	4
Configuring BRS for Voice over Frame Relay . . . . .	4
Priority Queuing . . . . .	5
Priority Queuing Without Bandwidth Reservation . . . . .	6
Configuring Traffic Classes . . . . .	6
BRS and Filtering . . . . .	7
MAC Address Filtering and Tags . . . . .	7
TCP/UDP Port Number Filtering . . . . .	7
IPv4 TOS Bit Filtering . . . . .	8
Using IP Version 4 Precedence Bit Processing for SNA Traffic in IP Secure Tunnels and Secondary Fragments . . . . .	9
SNA and APPN Filtering for Bridged Traffic . . . . .	10
Order of Filtering Precedence . . . . .	11
Sample Configurations . . . . .	11
Using Default Circuit Definitions for Traffic Class Handling of Frame Relay Circuits . . . . .	11
<b>Chapter 2. Configuring and Monitoring Bandwidth Reservation</b> . . . . .	19
Bandwidth Reservation Configuration Overview . . . . .	19
Bandwidth Reservation Configuration Commands . . . . .	20
Activate-IP-precedence-filtering . . . . .	23
Add-circuit-class . . . . .	24
Add-class . . . . .	24
Assign . . . . .	25
Assign-circuit . . . . .	28
Change-circuit-class . . . . .	28
Change-class . . . . .	28
Circuit . . . . .	28
Clear-block . . . . .	29
Create-super-class . . . . .	30

Deactivate-IP-precedence-filtering . . . . .	30
Deassign . . . . .	30
Deassign-circuit . . . . .	30
Default-circuit-class . . . . .	30
Del-circuit-class. . . . .	31
Default-class. . . . .	31
Del-class . . . . .	31
Disable. . . . .	32
Disable-hpr-over-ip-port-numbers . . . . .	32
Enable . . . . .	32
Enable-hpr-over-ip-port-numbers . . . . .	33
Interface . . . . .	34
List . . . . .	34
Queue-length . . . . .	37
Set-circuit-defaults . . . . .	38
Show . . . . .	38
Tag . . . . .	38
Untag . . . . .	39
Use-circuit-defaults . . . . .	39
Accessing the Bandwidth Reservation Monitoring Prompt . . . . .	40
Bandwidth Reservation Monitoring Commands . . . . .	40
Circuit . . . . .	41
Clear . . . . .	41
Clear-Circuit-Class . . . . .	41
Counters . . . . .	42
Counters-circuit-class . . . . .	42
Interface . . . . .	43
Last . . . . .	43
Last-circuit-class . . . . .	43
Bandwidth Reservation Dynamic Reconfiguration Support . . . . .	43
CONFIG (Talk 6) Delete Interface . . . . .	43
GWCON (Talk 5) Activate Interface . . . . .	44
GWCON (Talk 5) Reset Interface . . . . .	44
CONFIG (Talk 6) Immediate Change Commands . . . . .	44
<b>Chapter 3. Using MAC Filtering . . . . .</b>	<b>47</b>
MAC Filtering and DLSw Traffic. . . . .	47
MAC Filtering Parameters . . . . .	47
Filter-Item Parameters . . . . .	48
Filter-List Parameters . . . . .	48
Filter Parameters . . . . .	48
Using MAC Filtering Tags . . . . .	49
<b>Chapter 4. Configuring and Monitoring MAC Filtering . . . . .</b>	<b>51</b>
Accessing the MAC Filtering Configuration Prompt. . . . .	51
MAC Filtering Configuration Commands. . . . .	51
Attach . . . . .	52
Create . . . . .	52
Default . . . . .	52
Delete . . . . .	53
Detach . . . . .	53
Disable. . . . .	53
Enable . . . . .	54
List . . . . .	54
Move . . . . .	54
Reinit . . . . .	55

Set-Cache . . . . .	55
Update . . . . .	55
Update Subcommands . . . . .	55
Add . . . . .	56
Delete . . . . .	57
List . . . . .	57
Move . . . . .	58
Set-Action. . . . .	58
Accessing the MAC Filtering Monitoring Prompt . . . . .	58
MAC Filtering Monitoring Commands . . . . .	59
Clear . . . . .	59
Disable . . . . .	59
Enable . . . . .	60
List . . . . .	60
Reinit . . . . .	60
MAC Filtering Dynamic Reconfiguration Support . . . . .	61
CONFIG (Talk 6) Delete Interface . . . . .	61
GWCON (Talk 5) Activate Interface . . . . .	61
GWCON (Talk 5) Reset Interface . . . . .	61
GWCON (Talk 5) Component Reset Command . . . . .	61
CONFIG (Talk 6) Activate Command . . . . .	61
<b>Chapter 5. Using WAN Restoral . . . . .</b>	<b>63</b>
Overview for WAN Restoral, WAN Reroute, and Dial-on-Overflow . . . . .	63
WAN Restoral . . . . .	63
WAN Reroute . . . . .	63
Dial-on-overflow . . . . .	64
Before You Begin . . . . .	65
Configuration Procedure for WAN Restoral . . . . .	65
Secondary Dial Circuit Configuration . . . . .	66
<b>Chapter 6. Configuring and Monitoring WAN Restoral . . . . .</b>	<b>67</b>
WAN Restoral, WAN Reroute, and Dial-on-Overflow Configuration Commands . . . . .	67
Add . . . . .	67
Disable . . . . .	68
Enable . . . . .	69
List . . . . .	70
Remove . . . . .	71
Set . . . . .	72
Accessing the WAN Restoral Interface Monitoring Process . . . . .	74
WAN Restoral Monitoring Commands . . . . .	74
Clear . . . . .	75
Disable . . . . .	75
Enable . . . . .	76
Set . . . . .	77
List . . . . .	79
WAN Restoral and WAN Reroute Dynamic Reconfiguration Support . . . . .	84
CONFIG (Talk 6) Delete Interface . . . . .	84
GWCON (Talk 5) Activate Interface . . . . .	84
GWCON (Talk 5) Reset Interface . . . . .	84
GWCON (Talk 5) Temporary Change Commands . . . . .	84
<b>Chapter 7. The WAN Reroute Feature . . . . .</b>	<b>87</b>
WAN Reroute Overview . . . . .	87
Dial-on-Overflow . . . . .	88
Configuring WAN Reroute . . . . .	89

Sample WAN Reroute Configuration . . . . .	89
--	----

<b>Chapter 8. Using the Network Dispatcher Feature . . . . .</b>	<b>95</b>
Overview of Network Dispatcher . . . . .	95
Balancing TCP and UDP Traffic Using Network Dispatcher. . . . .	96
High Availability for Network Dispatcher . . . . .	97
Failure Detection . . . . .	98
Database Synchronization. . . . .	98
Recovery Strategy . . . . .	98
IP Takeover . . . . .	98
Configuring Network Dispatcher. . . . .	99
Configuration Steps. . . . .	101
Using Network Dispatcher with TN3270 Server . . . . .	106
Keys to Configuration . . . . .	106
Explicit LUs and Network Dispatcher . . . . .	109
Using Network Dispatcher with Cluster Address Advertising . . . . .	109
Using Network Dispatcher with Web Server Cache . . . . .	110
Using Network Dispatcher with eNetwork Host On-Demand Client Cache . . . . .	111
Using Network Dispatcher with Scalable High Availability Cache (SHAC) . . . . .	111

<b>Chapter 9. Configuring and Monitoring the Network Dispatcher Feature . . . . .</b>	<b>113</b>
Accessing the Network Dispatcher Configuration Commands . . . . .	113
Network Dispatcher Configuration Commands . . . . .	113
Add . . . . .	113
Clear . . . . .	120
Disable . . . . .	120
Enable . . . . .	121
List. . . . .	123
Remove . . . . .	124
Set. . . . .	126
Accessing the Network Dispatcher Monitoring Commands . . . . .	131
Network Dispatcher Monitoring Commands . . . . .	132
List. . . . .	132
Quiesce . . . . .	133
Report . . . . .	134
Status. . . . .	136
Switchover . . . . .	139
Unquiesce . . . . .	139
Network Dispatcher Dynamic Reconfiguration Support . . . . .	140
CONFIG (Talk 6) Delete Interface . . . . .	140
GWCON (Talk 5) Activate Interface . . . . .	140
GWCON (Talk 5) Reset Interface. . . . .	140
CONFIG (Talk 6) Immediate Change Commands . . . . .	140
Non-Dynamically Reconfigurable Commands . . . . .	141

<b>Chapter 10. Configuring and Monitoring IBM eNetwork Host On-Demand Client Cache . . . . .</b>	<b>143</b>
Configuring the Host On-Demand Client Cache . . . . .	144
Accessing the Host On-Demand Client Cache Configuration Environment . . . . .	148
Host On-Demand Client Cache Commands . . . . .	148
Activate . . . . .	148
Add . . . . .	149
Delete. . . . .	149
List. . . . .	149
Modify . . . . .	150
Accessing the Host On-Demand Client Cache Monitoring Environment . . . . .	151



Host On-Demand Client Cache Monitoring Commands . . . . .	151
Activate . . . . .	151
Clear . . . . .	152
Enable . . . . .	152
Delete. . . . .	152
Disable . . . . .	153
List. . . . .	153
Modify . . . . .	155
Host On-Demand Client Cache Dynamic Reconfiguration Support . . . . .	155
CONFIG (Talk 6) Delete Interface . . . . .	155
GWCON (Talk 5) Activate Interface . . . . .	155
GWCON (Talk 5) Reset Interface. . . . .	155
GWCON (Talk 5) Component Reset Commands . . . . .	155
CONFIG (Talk 6) Activate Commands . . . . .	157
GWCON (Talk 5) Temporary Change Commands . . . . .	157
<b>Chapter 11. Using Web Server Cache . . . . .</b>	<b>159</b>
Web Server Cache Overview . . . . .	159
Caching . . . . .	161
Using the HTTP Proxy. . . . .	163
Scalable High Availability Cache . . . . .	164
External Cache Control Manager Overview . . . . .	168
Dependency Table . . . . .	169
External Cache Control Protocol . . . . .	170
External Cache Control Protocol (ECCP) Vector Formats . . . . .	172
<b>Chapter 12. Configuring and Monitoring Web Server Cache . . . . .</b>	<b>197</b>
Configuring the Web Server Cache . . . . .	197
Accessing the Web Server Cache Environment . . . . .	203
Web Server Cache Commands . . . . .	203
Activate . . . . .	203
Add . . . . .	203
Delete. . . . .	204
List. . . . .	205
Modify . . . . .	206
Accessing the Web Server Cache Monitoring Environment . . . . .	209
Web Server Cache Monitoring Commands . . . . .	210
Activate . . . . .	210
Clear . . . . .	210
Enable . . . . .	211
Delete. . . . .	211
Disable . . . . .	212
List. . . . .	212
Modify . . . . .	215
Web Server Cache Dynamic Reconfiguration Support . . . . .	215
CONFIG (Talk 6) Delete Interface . . . . .	215
GWCON (Talk 5) Activate Interface . . . . .	215
GWCON (Talk 5) Reset Interface. . . . .	215
GWCON (Talk 5) Component Reset Commands . . . . .	216
CONFIG (Talk 6) Activate Commands . . . . .	217
GWCON (Talk 5) Temporary Change Commands . . . . .	218
<b>Chapter 13. Configuring and Monitoring the Encoding Subsystem . . . . .</b>	<b>219</b>
Configuring the Encoding Subsystem . . . . .	219
List. . . . .	220
Set. . . . .	220

Monitoring the Encoding Subsystem . . . . .	221
List . . . . .	222
Encoding Subsystem Dynamic Reconfiguration Support . . . . .	225
CONFIG (Talk 6) Delete Interface . . . . .	225
GWCON (Talk 5) Activate Interface . . . . .	225
GWCON (Talk 5) Reset Interface . . . . .	225
Non-Dynamically Reconfigurable Commands . . . . .	225
<b>Chapter 14. Configuring and Monitoring Data Compression . . . . .</b>	<b>227</b>
Data Compression Overview . . . . .	227
Data Compression Concepts . . . . .	227
Data Compression Basics . . . . .	228
Considerations . . . . .	230
Configuring and Monitoring Data Compression on PPP Links . . . . .	232
Configuring Data Compression on PPP Links . . . . .	232
Monitoring Data Compression on PPP Links . . . . .	233
Configuring and Monitoring Data Compression on Frame Relay Links . . . . .	234
Configuring Data Compression on Frame Relay Links . . . . .	234
Monitoring Data Compression on Frame Relay Links . . . . .	236
Example: Monitoring Compression on a Frame Relay Interface or Circuit . . . . .	236
<b>Chapter 15. Using Local or Remote Authentication . . . . .</b>	<b>239</b>
Using Authentication, Authorization, and Accounting (AAA) Security . . . . .	239
What is AAA Security? . . . . .	239
Using PPP . . . . .	240
Valid PPP Security Protocols . . . . .	240
Using Login . . . . .	240
Valid Login/Admin Security Protocols . . . . .	241
Using Tunnels . . . . .	242
Valid Tunnel Security Protocols . . . . .	242
Password Rules . . . . .	242
Understanding Authentication Servers . . . . .	243
SecurID Support . . . . .	243
<b>Chapter 16. Configuring Authentication . . . . .</b>	<b>245</b>
Accessing the Authentication Configuration Prompt . . . . .	245
Authentication Configuration Commands . . . . .	245
Disable . . . . .	245
Enable . . . . .	246
List . . . . .	246
Login . . . . .	248
Nets-info . . . . .	250
Password-rules . . . . .	250
PPP . . . . .	252
Servers . . . . .	253
Set . . . . .	257
Tunnel . . . . .	259
User-profiles . . . . .	260
Authentication (AAA) Dynamic Reconfiguration Support . . . . .	264
CONFIG (Talk 6) Delete Interface . . . . .	264
GWCON (Talk 5) Activate Interface . . . . .	264
GWCON (Talk 5) Reset Interface . . . . .	265
CONFIG (Talk 6) Immediate Change Commands . . . . .	265
Non-Dynamically Reconfigurable Commands . . . . .	265
<b>Chapter 17. Using and Configuring Encryption Protocols . . . . .</b>	<b>267</b>

PPP Encryption Using Encryption Control Protocol . . . . .	267
Configuring ECP Encryption for PPP . . . . .	267
Monitoring ECP Encryption for PPP . . . . .	268
Microsoft Point-to-Point Encryption (MPPE) . . . . .	268
Configuring MPPE . . . . .	268
Monitoring MPPE . . . . .	269
Configuring Encryption on Frame Relay Interfaces . . . . .	269
Monitoring Encryption on Frame Relay Interfaces . . . . .	270
<b>Chapter 18. Using the Policy Feature . . . . .</b>	<b>271</b>
Overview of Policy . . . . .	271
Policy Decision and Enforcement. . . . .	271
Policy Objects. . . . .	273
LDAP and Policy Database Interaction. . . . .	278
Policy Schema . . . . .	280
Generating Rules . . . . .	282
Configuration Examples . . . . .	283
IPSec/ISAKMP Policy with QoS . . . . .	283
IPSec/ISAKMP Only Policy . . . . .	293
Drop All Public Traffic (Filter Rule) . . . . .	295
Configuring and Enabling the LDAP Policy Search Engine . . . . .	298
Policy Quick Config Example . . . . .	300
Predefined Policy Objects . . . . .	302
<b>Chapter 19. Configuring and Monitoring the Policy Feature . . . . .</b>	<b>309</b>
Accessing the Policy Configuration Prompt . . . . .	309
Policy Configuration Commands . . . . .	309
Add . . . . .	309
Change . . . . .	324
Copy . . . . .	324
Delete. . . . .	324
Disable . . . . .	324
Enable . . . . .	324
List. . . . .	324
Qconfig . . . . .	325
LDAP Policy Server Configuration Commands . . . . .	327
Disable LDAP . . . . .	328
Enable LDAP . . . . .	328
Set Default-Policy . . . . .	328
Set LDAP . . . . .	330
Set Refresh . . . . .	331
Accessing the Policy Monitoring Prompt . . . . .	332
Policy Monitoring Commands . . . . .	332
Cache-LDAP-Plcys . . . . .	332
Check-Consistency . . . . .	333
Disable . . . . .	334
Enable . . . . .	334
Flush-Cache . . . . .	334
Reset . . . . .	334
Search . . . . .	335
Status. . . . .	335
List. . . . .	335
Test . . . . .	336
Policy Dynamic Reconfiguration Support . . . . .	337
CONFIG (Talk 6) Delete Interface . . . . .	337
GWCON (Talk 5) Activate Interface . . . . .	337

GWCON (Talk 5) Reset Interface . . . . .	337
GWCON (Talk 5) Component Reset Commands . . . . .	337
CONFIG (Talk 6) Immediate Change Commands . . . . .	339

<b>Chapter 20. Using IP Security . . . . .</b>	<b>341</b>
IP Security Overview . . . . .	341
Using Secure Tunnels . . . . .	341
IP Security Concepts . . . . .	341
IP Security Terminology . . . . .	342
IP Authentication Header . . . . .	344
IP Encapsulating Security Payload . . . . .	344
Using AH and ESP . . . . .	345
Security Associations . . . . .	345
Tunnel Mode and Transport Mode . . . . .	345
Tunnel-in-Tunnel Mode . . . . .	348
Path Maximum Transmission Unit Discovery . . . . .	348
Diagram of a Network with an IP Security Tunnel . . . . .	349
Using the Internet Key Exchange . . . . .	350
Internet Key Exchange Phases . . . . .	351
Negotiating an IP Security Tunnel . . . . .	351
Using Public Key Infrastructure . . . . .	352
Configuring PKI . . . . .	353
Using Manual IP Security (IPv4) . . . . .	356
Using Manual IP Security (IPv6) . . . . .	356

<b>Chapter 21. Configuring and Monitoring IP Security . . . . .</b>	<b>357</b>
Configuring Internet Key Exchange (IPv4) . . . . .	357
Configuring Public Key Infrastructure (IPv4) . . . . .	357
Obtaining a Certificate . . . . .	358
Public Key Infrastructure Configuration Commands . . . . .	358
Add . . . . .	358
Change . . . . .	359
Delete . . . . .	359
List . . . . .	360
Load . . . . .	361
Configuring Manual IP Security (IPv4) . . . . .	361
Configuring the Algorithms . . . . .	361
Configuring Encryption Keys . . . . .	362
Accessing the IP Security Configuration Environment . . . . .	362
Manual IP Security Configuration Commands . . . . .	362
Add Tunnel . . . . .	363
Change Tunnel . . . . .	367
Delete Tunnel . . . . .	367
Disable . . . . .	368
Enable . . . . .	368
List . . . . .	369
Set . . . . .	370
Configuring a Manual Tunnel (IPv4) . . . . .	370
Configuring the Tunnel for Router A . . . . .	370
Configuring the Tunnel for Router B . . . . .	371
Example: Manually Configuring an IP Security Tunnel with ESP . . . . .	371
Example: Manually Configuring an IP Security Tunnel with ESP and ESP-NULL . . . . .	371
Configuring Manual IP Security (IPv6) . . . . .	372
Configuring the Algorithms . . . . .	372
Configuring Encryption Keys . . . . .	372

Accessing the IP Security Configuration Environment . . . . .	372
Manual IP Security Configuration Commands . . . . .	373
Configuring a Manual Tunnel (IPv6). . . . .	373
Creating the IP Security Tunnel for Router A . . . . .	373
Configuring Packet Filters for Router A . . . . .	373
Configuring Packet Filter Access Control Rules for Router A. . . . .	374
Resetting IP Security and IP on Router A. . . . .	374
Creating the IP Security Tunnel for Router B . . . . .	375
Configuring Packet Filters for Router B . . . . .	375
Configuring Packet-Filter Access Control Rules for Router B. . . . .	375
Resetting IP Security and IPv6 on Router B. . . . .	375
Example: Configuring an IP Security Tunnel with ESP . . . . .	376
Example: Configuring an IP Security Tunnel with ESP and ESP-NULL . . . . .	376
Monitoring Manual IP Security (IPv4) . . . . .	376
Accessing the Internet Key Exchange Environment . . . . .	376
Internet Key Exchange Monitoring Commands . . . . .	377
Accessing the Public Key Infrastructure Environment (IPv4) . . . . .	378
Public Key Infrastructure Monitoring Commands . . . . .	378
Accessing the IP Security Monitoring Environment (IPv4) . . . . .	381
IP Security Monitoring Commands (IPv4). . . . .	381
Monitoring Manual IP Security (IPv6) . . . . .	387
Accessing the IP Security Monitoring Environment . . . . .	387
IP Security Monitoring Commands (IPv6). . . . .	387
IP Security Dynamic Reconfiguration Support . . . . .	387
CONFIG (Talk 6) Delete Interface . . . . .	387
GWCON (Talk 5) Activate Interface . . . . .	387
GWCON (Talk 5) Reset Interface. . . . .	387
GWCON (Talk 5) Component Reset Commands . . . . .	387
GWCON (Talk 5) Temporary Change Commands . . . . .	388
Non-Dynamically Reconfigurable Commands . . . . .	389
<b>Chapter 22. Using the Differentiated Services Feature . . . . .</b>	<b>391</b>
Overview of Differentiated Services . . . . .	391
Understanding the DiffServ Codepoint . . . . .	393
Understanding the Meters and Policer . . . . .	394
Understanding Buffer and Queue Management . . . . .	395
Understanding the Scheduler . . . . .	396
Differentiated Services Terminology . . . . .	396
Configuring Differentiated Services . . . . .	397
<b>Chapter 23. Configuring and Monitoring the Differentiated Services Feature . . . . .</b>	<b>399</b>
Accessing the Differentiated Services Configuration Prompt . . . . .	399
Differentiated Services Configuration Commands . . . . .	399
Delete. . . . .	399
Disable . . . . .	400
Enable . . . . .	400
List. . . . .	400
Set. . . . .	401
Accessing the Differentiated Services Monitoring Environment . . . . .	403
Differentiated Services Monitoring Commands . . . . .	404
Clear . . . . .	404
DScache. . . . .	404
List. . . . .	405
Differentiated Services Dynamic Reconfiguration Support . . . . .	410
CONFIG (Talk 6) Delete Interface . . . . .	410

GWCON (Talk 5) Activate Interface . . . . .	410
GWCON (Talk 5) Reset Interface . . . . .	410
Non-Dynamically Reconfigurable Commands . . . . .	410
<b>Chapter 24. Using the Random Early Detection Feature . . . . .</b>	<b>413</b>
Using Random Early Detection . . . . .	413
<b>Chapter 25. Configuring and Monitoring the Random Early Detection</b>	
<b>Feature . . . . .</b>	<b>415</b>
Accessing the Random Early Detection Configuration Prompt . . . . .	415
Random Early Detection Configuration Commands . . . . .	415
Delete. . . . .	415
Disable . . . . .	416
Enable . . . . .	416
List. . . . .	416
Set. . . . .	417
Accessing the Random Early Detection Monitoring Environment . . . . .	417
Random Early Detection Monitoring Commands . . . . .	417
Clear . . . . .	418
List. . . . .	418
<b>Chapter 26. Using Layer 2 Tunneling (L2TP, PPTP, L2F) . . . . .</b>	<b>419</b>
Overview of L2TP . . . . .	419
L2TP Terms . . . . .	420
Supported Features. . . . .	420
Timing Considerations. . . . .	422
LCP Considerations . . . . .	422
Configuring Layer 2 Tunneling . . . . .	422
<b>Chapter 27. Configuring and Monitoring Layer 2 Tunneling Protocols</b>	<b>427</b>
Accessing the L2T Interface Configuration Prompt . . . . .	427
L2 Tunneling Interface Configuration Commands . . . . .	427
Disable . . . . .	427
Enable . . . . .	428
Encapsulator . . . . .	428
List. . . . .	428
Set. . . . .	428
Accessing the L2 Tunneling Feature Configuration Prompt . . . . .	429
L2 Tunneling Feature Configuration Commands . . . . .	429
Add . . . . .	430
Disable . . . . .	430
Enable . . . . .	431
Encapsulator . . . . .	432
List. . . . .	432
Set. . . . .	433
Accessing the L2 Tunneling Monitoring Prompt . . . . .	434
L2 Tunneling Monitoring Commands . . . . .	435
Call . . . . .	435
Kill . . . . .	438
Memory . . . . .	438
Start . . . . .	438
Stop . . . . .	438
Tunnel . . . . .	438
L2 Tunneling Dynamic Reconfiguration Support . . . . .	441
CONFIG (Talk 6) Delete Interface . . . . .	441
GWCON (Talk 5) Activate Interface . . . . .	441

	GWCON (Talk 5) Reset Interface . . . . .	442
	CONFIG (Talk 6) Immediate Change Commands . . . . .	442
	Non-Dynamically Reconfigurable Commands . . . . .	443
	<b>Chapter 28. Using Network Address Translator . . . . .</b>	<b>445</b>
	Network Address Port Translator . . . . .	446
	Static Address Mappings . . . . .	447
	NAT Static Address Mapping . . . . .	447
	NAPT Static Address Mapping . . . . .	447
	Setting Packet Filters and Access Control Rules for NAT . . . . .	448
	Example: Configuration of NAT With IP Filters and Access Control Rules . . . . .	448
	<b>Chapter 29. Configuring and Monitoring Network Address Translator . . . . .</b>	<b>451</b>
	Accessing the Network Address Translator Configuration Environment . . . . .	451
	Network Address Translator Configuration Commands . . . . .	451
	Change . . . . .	451
	Delete. . . . .	452
	Disable . . . . .	453
	Enable . . . . .	453
	List. . . . .	453
	Map . . . . .	454
	Reserve . . . . .	455
	Reset . . . . .	456
	Set. . . . .	456
	Translate . . . . .	457
	Accessing the Network Address Translator Monitoring Environment . . . . .	457
	Network Address Translator Monitoring Commands . . . . .	458
	List. . . . .	458
	Reset . . . . .	459
	NAT Dynamic Reconfiguration Support. . . . .	459
	CONFIG (Talk 6) Delete Interface . . . . .	459
	GWCON (Talk 5) Activate Interface . . . . .	459
	GWCON (Talk 5) Reset Interface. . . . .	459
	GWCON (Talk 5) Component Reset Commands . . . . .	459
	CONFIG (Talk 6) Immediate Change Commands . . . . .	460
	<b>Chapter 30. Using a Dial-In Access to LANs (DIALs) Server . . . . .</b>	<b>461</b>
	Before Using Dial-In-Access . . . . .	462
	Configuring Dial-In Access . . . . .	462
	Configuring Dial-In Interfaces . . . . .	462
	Before Configuring Dial-Out Interfaces . . . . .	464
	Null Modem Usage . . . . .	464
	Configuring Dial-Out Interfaces . . . . .	465
	Before Configuring Global DIALs Parameters . . . . .	466
	Server Provided IP Addresses . . . . .	466
	Dynamic Host Configuration Protocol (DHCP) . . . . .	467
	Dynamic Domain Name Server (DDNS) . . . . .	468
	<b>Chapter 31. Configuring DIALs . . . . .</b>	<b>471</b>
	Accessing the DIALs Global Configuration Environment . . . . .	471
	DIALs Global Configuration Commands . . . . .	471
	Add . . . . .	472
	Delete. . . . .	472
	Disable . . . . .	473
	Enable . . . . .	474
	List. . . . .	474

Set . . . . .	476
Accessing the DIALs Global Monitoring Environment . . . . .	479
DIALs Global Monitoring Commands . . . . .	479
Clear . . . . .	479
List . . . . .	480
Reset . . . . .	481
dial-out Interface Configuration Commands . . . . .	482
Set . . . . .	482
Monitoring Dial-In Interfaces . . . . .	483
Monitoring dial-out Interfaces . . . . .	483
Clear . . . . .	483
List . . . . .	483
DIALs Server Dynamic Reconfiguration Support . . . . .	484
CONFIG (Talk 6) Delete Interface . . . . .	484
GWCON (Talk 5) Activate Interface . . . . .	484
GWCON (Talk 5) Reset Interface . . . . .	484
GWCON (Talk 5) Component Reset Commands . . . . .	485
CONFIG (Talk 6) Immediate Change Commands . . . . .	487
Non-Dynamically Reconfigurable Commands . . . . .	487
Dial-Out Dynamic Reconfiguration Support . . . . .	487
CONFIG (Talk 6) Delete Interface Command . . . . .	488
GWCON (Talk 5) Activate Interface Command . . . . .	488
GWCON (Talk 5) Reset Interface Command . . . . .	488
<b>Chapter 32. Using DHCP Server . . . . .</b>	<b>489</b>
Introduction to DHCP . . . . .	489
DHCP Operation . . . . .	489
Lease Renewals . . . . .	490
Client Movement . . . . .	491
Changing Server Options . . . . .	491
Number of DHCP servers . . . . .	491
A Single DHCP server . . . . .	491
Multiple DHCP servers . . . . .	492
BOOTP Servers . . . . .	492
Special DHCP Clients . . . . .	492
Lease Times . . . . .	493
Concepts and Terminology . . . . .	493
DHCP Server and Lease Parameters . . . . .	496
DHCP Options . . . . .	496
Option Formats . . . . .	496
Base Options Provided to the Client . . . . .	498
IP Layer Parameters per Host Options . . . . .	500
IP Layer Parameters per Interface Options . . . . .	501
Link Layer Parameters per Interface Options . . . . .	501
TCP Parameter Options . . . . .	502
Application and Service Parameter Options . . . . .	502
DHCP Extensions Options . . . . .	504
IBM-specific Options . . . . .	507
Vendor Options . . . . .	507
Configuring IP for DHCP . . . . .	507
Adding an IP Address . . . . .	508
Using IP Simple-Internet-Access . . . . .	508
Sample DHCP Server Configuration . . . . .	509
ASCII Text File . . . . .	509
OPCON (Talk 6) Configuration . . . . .	510



<b>Chapter 33. Configuring and Monitoring DHCP Server.</b>	515
Accessing the DHCP Server Configuration Environment	515
DHCP Server Configuration Commands	515
Add	515
Change	521
Delete.	525
Disable	529
Enable	529
List.	529
Set.	536
Accessing the DHCP Server Monitoring Environment	543
DHCP Server Monitoring Commands	544
Disable	544
Enable	544
List.	544
Reset.	545
Request	545
DHCP Dynamic Reconfiguration Support	547
CONFIG (Talk 6) Delete Interface	547
GWCON (Talk 5) Activate Interface	547
GWCON (Talk 5) Reset Interface.	547
GWCON (Talk 5) Component Reset Commands	547
GWCON (Talk 5) Temporary Change Commands	548
Non-Dynamically Reconfigurable Commands	549
<b>Chapter 34. Using Thin Server Feature.</b>	551
Network Station Overview	551
Thin Server Feature Overview	551
BootP/DHCP Support	553
Protocols Used to Communicate with the Network Stations	553
Using RFS	554
Using TFTP	554
Using NFS	554
File Cache Updates.	555
Configuring the Thin Server Environment	556
Configuration Recommendations	556
Configuring the BootP/DHCP Server	557
Configuring the Server for the Thin Server Environment	557
Configuring BootP Relay	557
Configuring the Internal IP Address	558
Configuring the TSF	558
Sample Configuration	558
Configuring the AS/400	558
Configuring the IBM 2212 (TSF)	560
<b>Chapter 35. Configuring and Monitoring Thin Server Function</b>	563
Accessing the TSF Configuration Environment	563
TSF Configuration Commands	563
Add	563
Delete.	570
List.	570
Modify	571
Set.	572
Accessing the TSF Monitoring Environment	574
TSF Monitoring Commands	575
Delete.	575

Flush . . . . .	575
List . . . . .	576
Refresh . . . . .	579
Reset . . . . .	579
Restart . . . . .	579
Set . . . . .	580
TSF Dynamic Reconfiguration Support. . . . .	580
CONFIG (Talk 6) Delete Interface . . . . .	580
GWCON (Talk 5) Activate Interface . . . . .	580
GWCON (Talk 5) Reset Interface . . . . .	580
GWCON (Talk 5) Component Reset Commands . . . . .	580
GWCON (Talk 5) Temporary Change Commands . . . . .	581
Non-Dynamically Reconfigurable Commands . . . . .	581
<b>Chapter 36. Configuring and Monitoring VCRM . . . . .</b>	<b>583</b>
Accessing the VCRM Configuration Environment . . . . .	583
Accessing the VCRM Monitoring Environment . . . . .	583
VCRM Monitoring Commands . . . . .	584
Clear . . . . .	584
Queue . . . . .	584
<b>Chapter 37. Using the Voice Feature. . . . .</b>	<b>587</b>
Voice Adapter Overview . . . . .	587
Voice Features . . . . .	587
Configuration Concepts . . . . .	587
Voice over Frame Relay Configuration Information . . . . .	588
Communicating with an IBM 9783 . . . . .	589
Network Configurations without an IBM 9783 . . . . .	592
<b>Chapter 38. Configuring and Monitoring the Voice Feature . . . . .</b>	<b>593</b>
Accessing the Voice Feature Commands . . . . .	593
Voice Feature Commands . . . . .	593
Add . . . . .	594
Delete. . . . .	594
List . . . . .	595
Modify . . . . .	595
Set . . . . .	595
VoFR . . . . .	599
Accessing the Voice Interface Commands . . . . .	599
Voice Interface Commands . . . . .	600
List . . . . .	600
Set . . . . .	601
Accessing the Voice over Frame Relay (VoFR) Commands . . . . .	604
Voice over Frame Relay (VoFR) Commands . . . . .	605
Add . . . . .	605
Delete. . . . .	608
Disable . . . . .	608
Enable . . . . .	608
List . . . . .	608
Modify . . . . .	610
Reorder-call-rule . . . . .	611
Set . . . . .	611
Accessing the Voice Interface Monitoring Environment . . . . .	612
Voice Interface Monitoring Commands . . . . .	612
Calls . . . . .	612
Status. . . . .	614

Trace Call . . . . .	616
Voice Feature Dynamic Reconfiguration Support . . . . .	616
CONFIG (Talk 6) Delete Interface . . . . .	616
GWCON (Talk 5) Activate Interface . . . . .	616
GWCON (Talk 5) Reset Interface . . . . .	616
Voice Interfaces Dynamic Reconfiguration Support . . . . .	616
CONFIG (Talk 6) Delete Interface . . . . .	616
GWCON (Talk 5) Activate Interface . . . . .	616
GWCON (Talk 5) Reset Interface . . . . .	616
<b>Appendix. Remote AAA Attributes . . . . .</b>	<b>617</b>
Radius . . . . .	617
Keywords . . . . .	618
Example of RADIUS Configuration File . . . . .	619
TACACS+ . . . . .	621
<b>List of Abbreviations . . . . .</b>	<b>623</b>
<b>Glossary . . . . .</b>	<b>633</b>
<b>Index . . . . .</b>	<b>657</b>
<b>Readers' Comments — We'd Like to Hear from You . . . . .</b>	<b>671</b>



## Figures

1.	PPP BRS Traffic Class and Traffic Class Priority Queue Relationship . . . . .	2
2.	Frame Relay BRS Circuit Class and Traffic Class Relationship . . . . .	2
3.	WAN Reroute . . . . .	88
4.	Sample WAN Reroute Configuration. . . . .	90
5.	Example of Network Dispatcher Configured With a Single Cluster and 2 Ports . . . . .	99
6.	Example of Network Dispatcher Configured With 3 Clusters and 3 URLs . . . . .	100
7.	Example of Network Dispatcher Configured with 3 Clusters and 3 Ports . . . . .	101
8.	High Availability Network Dispatcher Configuration . . . . .	102
9.	Lan Connected Servers . . . . .	112
10.	Network Dispatcher without Web Server Cache . . . . .	159
11.	Network Dispatcher with Web Server Cache and No Cache Hit . . . . .	160
12.	Network Dispatcher with Web Server Cache and Cache Hit . . . . .	161
13.	Cache Request Found . . . . .	165
14.	Request Forwarded to the Responsible Cache . . . . .	166
15.	Request Forwarded to Backend Server . . . . .	166
16.	Request Forwarded to the Responsible Cache and Not Found . . . . .	167
17.	Two caches with Network Dispatcher, client and backend server . . . . .	168
18.	Command Response Vector . . . . .	172
19.	Subvector Format . . . . .	176
20.	Subfield Format . . . . .	192
21.	Example of Bidirectional Data Compression with Data Dictionaries . . . . .	230
22.	Example of Configuring Compression on a PPP Link . . . . .	233
23.	Monitoring Compression on a PPP Interface . . . . .	234
24.	Example of Configuring Compression on a Frame Relay Link . . . . .	235
25.	SecurID Username and Passcode . . . . .	243
26.	SecurID Passcode with Next Token . . . . .	244
27.	IP Packet Flow and the Policy Database. . . . .	272
28.	Relationship of Policy Configuration Objects . . . . .	278
29.	Securing Traffic Across the Internet . . . . .	280
30.	Policy Schema Structure . . . . .	281
31.	Configuring IPSec/ISAKMP with QoS . . . . .	283
32.	Configuring IPSec and Reusing a Previous Definition . . . . .	293
33.	Creation of an HMAC MD5-Authenticated Message . . . . .	344
34.	AH-Protected Datagram Format . . . . .	346
35.	ESP-Protected Datagram Format . . . . .	347
36.	Nesting ESP Within an AH Tunnel . . . . .	347
37.	IPSec-Protected L2TP Packet . . . . .	348
38.	Network with IPSec and NAT . . . . .	350
39.	DiffServ Data Packet Path . . . . .	391
40.	Relationship of Policer, Buffers, Queues, and Scheduler . . . . .	393
41.	DiffServ Codepoint Format for IPv4 TOS Octet Header . . . . .	393
42.	DiffServ Codepoint Format for AF PHB Header . . . . .	394
43.	Sample L2TP Network . . . . .	420
44.	Network Running NAT . . . . .	446
45.	Network Running NAT . . . . .	448
46.	An Example of a DIALs Server Supporting Dial-In . . . . .	461
47.	An Example of a DIALs Server Supporting Dial-Out . . . . .	462
48.	Adding a Dial-In Interface . . . . .	464
49.	Scope Concepts . . . . .	494
50.	Remote Network Station without a Thin Server . . . . .	552
51.	Remote Network Station with a Thin Server . . . . .	553
52.	TSF Sample Configuration . . . . .	558
53.	IBM 9783 to 2212 Voice Interfaces Communication. . . . .	589

| 54. Configuring Voice Port Call Processing Information . . . . . 590

## Tables

1.	Bandwidth Reservation Configuration Command Summary (Available from BRS Config> prompt)	20
2.	BRS Interface Configuration Commands Available from BRS [i #] Config> prompt for Frame Relay Interfaces	21
3.	BRS Traffic Class Handling Commands	22
4.	Bandwidth Reservation Monitoring Command Summary	40
5.	MAC Filtering Configuration Command Summary	51
6.	Update Subcommands Summary	55
7.	MAC Filtering Monitoring Command Summary	59
8.	WAN Restoral Configuration Commands Summary	67
9.	WAN Restoral Monitoring Commands	74
10.	Commands to alias the loopback device (lo0) for Dispatcher	104
11.	Commands to Delete Routes for Various Operating Systems	106
12.	Network Dispatcher Configuration Commands	113
13.	Advisor Names and Port Numbers	114
14.	Parameter Configuration Limits	120
15.	Network Dispatcher Monitoring Commands	132
16.	Host On-Demand Client Cache Configuration Commands Summary	148
17.	Host On-Demand Client Cache Monitoring Commands Summary	151
18.	Web Server Cache Configuration Commands Summary	203
19.	Web Server Cache Monitoring Commands Summary	210
20.	ES Configuration Commands	220
21.	ES Monitoring Command	221
22.	PPP Data Compression Configuration Commands	233
23.	PPP Data Compression Monitoring Commands	233
24.	Data Compression Configuration Commands	235
25.	Frame Relay Data Compression Monitoring Commands	236
26.	Set PPP Security Protocols	240
27.	Set Login Security Protocols	242
28.	Set Tunnel Security Protocols	242
29.	Authentication Configuration Commands	245
30.	Login Subcommands	248
31.	Login Subcommands	250
32.	PPP Subcommands	252
33.	Server Subcommands	253
34.	Tunnel Subcommands	259
35.	User-profile Configuration Commands	260
36.	IKE Phase 1 Queries and the Decisions Returned	273
37.	IKE Phase 2 Queries and the Decisions Returned	273
38.	Policy Configuration Commands	309
39.	LDAP Configuration Commands	327
40.	Policy Monitoring Commands	332
41.	Algorithms Configured with Various Tunnel Policies	361
42.	IP Security Configuration Commands Summary	362
43.	Algorithms Configured with Various Tunnel Policies	372
44.	IKE Monitoring Commands Summary	377
45.	PKI Monitoring Commands Summary	378
46.	IP Security Monitoring Commands Summary	381
47.	DiffServ Configuration Commands	399
48.	DiffServ Monitoring Commands	404
49.	Random Early Detection Configuration Commands	415
50.	RED Monitoring Commands	417
51.	L2 Tunneling Interface Configuration Commands	427
52.	L2 Tunneling Feature Configuration Commands	429

53.	L2 Tunneling Monitoring Commands . . . . .	435
54.	NAT Configuration Commands . . . . .	451
55.	NAT Monitoring Commands . . . . .	458
56.	DIALs Global Configuration Commands . . . . .	471
57.	DIALs Global Monitoring Commands . . . . .	479
58.	dial-out Interface Configuration Commands. . . . .	482
59.	dial-out Interface Monitoring Commands. . . . .	483
60.	DHCP Server Configuration Command Summary . . . . .	515
61.	DHCP Server Monitoring Command Summary . . . . .	544
62.	TSF Configuration Command Summary . . . . .	563
63.	TSF Monitoring Command Summary . . . . .	575
64.	VCRM Monitoring Commands . . . . .	584
65.	Voice Feature Command Summary . . . . .	593
66.	Voice Interface Command Summary . . . . .	600
67.	VoFR Configuration Command Summary . . . . .	605
68.	Voice Interface Monitoring Command Summary . . . . .	612



---

## Notices

IBM may not offer the products, services, or features discussed in this document in other countries. Consult your local IBM representative for information on the products and services currently available in your area. Any reference to an IBM product, program, or service is not intended to state or imply that only that IBM product, program, or service may be used. Any functionally equivalent product, program, or service that does not infringe any IBM intellectual property right may be used instead. However, it is the user's responsibility to evaluate and verify the operation of any non-IBM product, program, or service.

IBM may have patents or pending patent applications covering the subject matter in this document. The furnishing of this document does not give you any license to these patents. You can send license inquiries, in writing, to:

IBM Director of Licensing  
IBM Corporation  
North Castle Drive  
Armonk, NY 10504-1785  
U.S.A.

For license inquiries regarding double-byte (DBCS) information, contact the IBM Intellectual Property Department in your country or send inquiries, in writing, to:

IBM World Trade Asia Corporation  
Licensing  
2-31 Roppongi 3-chome, Minato-ku  
Tokyo 106, Japan

The following paragraph does not apply to the United Kingdom or any other country where such provisions are inconsistent with local law: INTERNATIONAL BUSINESS MACHINES CORPORATION PROVIDES THIS PUBLICATION "AS IS" WITHOUT WARRANTY OF ANY KIND, EITHER EXPRESS OR IMPLIED, INCLUDING, BUT NOT LIMITED TO, THE IMPLIED WARRANTIES OF NON-INFRINGEMENT, MERCHANTABILITY, OR FITNESS FOR A PARTICULAR PURPOSE. Some states do not allow disclaimer of express or implied warranties in certain transactions, therefore, this statement may not apply to you.



## Trademarks

The following terms are trademarks of International Business Machines Corporation in the United States, or other countries, or both:

Advanced Peer-to-Peer Networking  
APPN  
eNetwork  
IBM  
OS/2  
SecureWay  
VTAM

Microsoft, Windows, Windows NT, and the Windows logo are trademarks or registered trademarks of Microsoft Corporation.

UNIX is a registered trademark in the United States and other countries licensed exclusively through X/Open Company Limited.

NetView is a trademark of Tivoli Systems, Inc. in the United States or other countries or both.

Java and all Java-based trademarks and logos are trademarks of Sun Microsystems, Inc. in the United States, other countries, or both.

Other company, product, and service names may be trademarks or service marks of others.



---

## Preface

This manual contains the information that you will need to use the router user interface for configuration and operation of the features installed on your IBM 2212. A specific IBM 2212 might not support all of the features described in this manual. If a feature is device-specific, you are informed of that by:

- A notice in the relevant chapter or section
- A section in the preface that lists the features and the devices that support them

This manual supports the IBM 2212 and refers to it as either a “router” or a “device.” The examples in the manual represent the configuration of an IBM 2212, but the actual output you see may vary. Use the examples as a guideline to what you might see while configuring your device.

---

## Who Should Read This Manual

This manual is intended for persons who install and manage computer networks. Although experience with computer networking hardware and software is helpful, you do not need programming experience to use the protocol software.

---

## Getting Additional Information

Changes may be made to the documentation after the books are printed. If additional information is available or if changes are required after the books have been printed, the changes will be in a file (named README) on the CD-ROM. You can view the file with an ASCII text editor.

---

## About the Software

IBM Access Integration Services is the software that supports the IBM 2212 (licensed program number 5639-F73). This software has these components:

- The base code, which consists of:
  - The code that provides the routing, bridging, data link switching, and SNMP agent functions for the device.
  - The router user interface, which allows you to configure, monitor, and use the Access Integration Services base code installed on the device. The router user interface is accessed locally through an ASCII terminal or emulator attached to the service port, or remotely through a Telnet session or modem-attached device.

The base code is installed at the factory on the 2212.

- The Configuration Program for IBM Access Integration Services (referred to in this book as the *Configuration Program*) is a graphical user interface that enables you to configure the device from a stand-alone workstation. The Configuration Program includes error checking and online help information.

The Configuration Program is not pre-loaded at the factory; it is shipped separately from the device as part of the software order.

You can also obtain the Configuration Program for IBM Access Integration Services from the IBM Networking Technical Support home page. See *Configuration Program User's Guide for Nways Multiprotocol and Access Services*, GC30-3830, for the server address and directories.

---

## Conventions Used in This Manual

The following conventions are used in this manual to show command syntax and program responses:

1. The abbreviated form of a command is underlined as shown in the following example:

```
reload
```

In this example, you can enter either the whole command (reload) or its abbreviation (rel).

2. Keyword choices for a parameter are enclosed in brackets and separated by the word or. For example:

```
command [keyword1 or keyword2]
```

Choose one of the keywords as a value for the parameter.

3. Three periods following an option mean that you enter additional data (for example, a variable) after the option. For example:

```
time host ...
```

In this example, you enter the IP address of the host in place of the periods, as explained in the description of the command.

4. In information displayed in response to a command, defaults for an option are enclosed in brackets immediately following the option. For example:

```
Media (UTP/STP) [UTP]
```

In this example, the media defaults to UTP unless you specify STP.

5. Keyboard key combinations are indicated in text in the following ways:
  - **Ctrl-P**
  - **Ctrl -**

The key combination **Ctrl -** indicates that you should press the Ctrl key and the hyphen simultaneously. In certain circumstances, this key combination changes the command line prompt.

6. Names of keyboard keys that you press are indicated like this: **Enter**
7. Variables (that is, names used to represent data that you define) are denoted by italics. For example:

```
File Name: filename.ext
```

---

## Library Overview

**Information updates and corrections:** To keep you informed of engineering changes, clarifications, and fixes that were implemented after the books were printed, refer to the IBM 2212 home pages at:

<http://www.networking.ibm.com/2212/2212prod.html>

The following list shows the books in the IBM 2212 library, arranged according to tasks.

### **Planning** **GA27-4215**

*IBM 2212 Introduction and Planning Guide*

This book is shipped with the IBM 2212. It explains how to prepare for installation and perform an initial configuration.

## **Installation**

### **GA27-4216**

*IBM 2212 Access Utility Installation and Initial Configuration Guide*

This booklet is shipped with the IBM 2212. It explains how to install the IBM 2212 and verify its installation.

### **GX27-4048**

*2212 Hardware Configuration Quick Reference*

This reference card is used for entering and saving hardware configuration information used to determine the correct state of an IBM 2212.

## **Diagnostics and Maintenance**

### **GY27-0362**

*IBM 2212 Access Utility Service and Maintenance Manual*

This book is shipped with the IBM 2212. It provides instructions for diagnosing problems with and repairing the IBM 2212.

## **Operations and Network Management**

The following list shows the books that support the Access Integration Services program.

### **SC30-3988**

*Software User's Guide*

This book explains how to:

- Configure, monitor, and use the Access Integration Services software.
- Use the Access Integration Services command-line router user interface to configure and monitor the network interfaces and link-layer protocols shipped with the IBM 2212.

### **SC30-3989**

*Using and Configuring Features*

### **SC30-3990**

*Protocol Configuration and Monitoring Reference Volume 1*

### **SC30-3991**

*Protocol Configuration and Monitoring Reference Volume 2*

These books describe how to access and use the Access Integration Services command-line user interface to configure and monitor the routing protocol software shipped with the product.

They include information about each of the protocols that the devices support.

### **SC30-3682**

*Event Logging System Messages Guide*

This book contains a listing of the error codes that can occur, along with descriptions and recommended actions to correct the errors.

## **Configuration**

### **GC30-3830**

*Configuration Program User's Guide for Nways Multiprotocol and Access Services*

This book discusses how to use the Configuration Program.

## Safety

### SD21-0030

*Caution: Safety Information—Read This First*

This book, shipped with the IBM 2212, provides translations of caution and danger notices applicable to the installation and maintenance of a IBM 2212.

## Marketing

The following IBM Web page provides product information:

<http://www.networking.ibm.com/2212/2212prod.html>

---

## Summary of Changes for the IBM 2212 Software Library

The following list applies to the changes in the software that were made in Version 3 Release 4:

- Frame Relay enhancements:
  - New Frame Handler (FH) support
  - PU throttling to handle bursts of traffic in support of 3745 controllers
  - New interface type (Frame Relay subinterface) to allow virtual interfaces on the same physical interface
  - Unnumbered IP support
- VPN enhancements:
  - CPE enhancements:
    - Policy information from LDAP servers is locally stored.
    - Policy quick configuration.
    - Policy consistency checking.
    - Policy information may now be retrieved from LDAP servers within an administrative domain.
    - IPsec tunnel ping.
  - IP enhancements:
    - Voice routing enhancements:
      - IP Header Compression on PPP (RFCs 2507, 2508, 2509)
      - Interleaving voice traffic between fragmented data packets on multi-link PPP
      - Interleaving voice traffic between fragmented data packets on Frame Relay
      - Bypassing PPP or Frame Relay packet compression and encryption for voice traffic
    - IP loopback address  
This support allows users to define IP addresses on a special interface to support TN3270 Gateway, Network Dispatcher, and IPsec requirements.
    - IPv6
      - An inter-domain routing function (BGP4+) is provided for IPv6 that supports IPv6 routing and addressing information and uses TCP6 for transport.
    - Multiple forwarding paths  
IP routing can use up to four equal-cost static routes to support multiple parallel links to a given address and mask.
    - IP route aggregation



## Summary of Changes

- Multicast enhancements:
  - Protocol Independent Multicast-Dense Mode (PIM-DM) for IPv4.
  - Network administrators can now control the flow of IP multicast data into and out of their networks by using inbound and outbound traffic filters.
- Not-so-stubby area (NSSA)  
OSPF supports not-so-stubby area (NSSA) as defined in RFC 1587 and the latest Internet draft is now supported.
- Random Early Detection (RED)
- Differential services policing enhancements
- VRRP enhancements:
  - The hardware MAC address may be used instead of a virtual MAC address to identify a redundant gateway; this can offer a performance improvement.
  - When more than one backup candidate is available, preempt options can be configured.
  - For selecting the master IP router, additional criteria, such as available route or network interface, can be used to support non-IP functions.
- Dial-on-demand alternate interface for WAN reroute
- TN3270 enhancements
  - LU capping
  - LU-pool load balancing
  - Talk 5 disconnect of TN3270 sessions
  - Additional reporting information
  - Support of addresses 1 and 255
- Network Dispatcher enhancements
  - Advertising of network dispatcher cluster addresses by routing protocols
  - A new SSL Advisor
- DLSw SDLC PU1 support
- Ethernet encapsulation support for both ethernet type II (default) and 802.3 simultaneously on the same interface
- DHCP enhancements:
  - Hardfile backup for lease information
  - Multiple IP address support for DHCP interfaces
  - Short lease support
- RADIUS enhancements
  - Radius scalability
  - Login of Last Resort
- L2TP Scalability
- Thin Server enhancement  
Connection to an alternate or back-up master server
- Service file retrieval enhancements

### Clarifications and corrections

In hard copy and PDF, the technical changes and additions are indicated by a vertical line (|) to the left of the change.

## Summary of Changes

---

### Getting Help

At the command prompts, you can obtain help in the form of a listing of the commands available at that level. To do this, type **?** (the **help** command), and then press **Enter**. Use **?** to list the commands that are available from the current level. You can usually enter a **?** after a specific command name to list its options.

---

### Exiting a Lower Level Environment

The multiple-level nature of the software places you in secondary, tertiary, and even lower level environments as you configure or operate the 2212. To return to the next higher level, enter the **exit** command. To get to the secondary level, continue entering **exit** until you receive the secondary level prompt (either `Config>` or `+`).

For example, to exit the ASRT protocol configuration process:

```
ASRT config> exit  
Config>
```

If you need to get to the primary level (OPCON), enter the intercept character (**Ctrl-P** by default).

---

# Chapter 1. Using Bandwidth Reservation and Priority Queuing

This chapter describes the Bandwidth Reservation System and priority queuing features currently available for Frame Relay and PPP interfaces. It includes the following sections:

- “Bandwidth Reservation System”
- “Bandwidth Reservation over Frame Relay” on page 3
- “Priority Queuing” on page 5
- “BRS and Filtering” on page 7
- “Sample Configurations” on page 11

---

## Bandwidth Reservation System

The Bandwidth Reservation System (BRS) allows you to decide which packets to drop when demand (traffic) exceeds supply (throughput) on a network connection. When bandwidth utilization reaches 100%, BRS determines which traffic to drop based on your configuration.

Bandwidth reservation “reserves” transmission bandwidth for specified classes of traffic. Each class has an allocated minimum percentage of the connection’s bandwidth. See Figure 1 on page 2 and Figure 2 on page 2.

On PPP interfaces, you define traffic classes (t-classes) and each traffic class is allocated a percentage of the PPP interface’s bandwidth. There are at least two traffic classes:

1. A LOCAL class which is allocated bandwidth for packets that are locally originated by the router (for example, IP RIP packets)
2. A DEFAULT class to which all other traffic is initially assigned.

You can create additional traffic classes and assign protocols, filters and tags to the priority queues within a traffic class. See Figure 1 on page 2.

On Frame Relay interfaces, you define circuit classes (c-classes) and each circuit class is allocated a percentage of the Frame Relay interface’s bandwidth. There is at least one circuit class: the DEFAULT circuit class to which all circuits are initially assigned. You can create additional circuit classes and assign circuits to these c-classes. On each Frame Relay circuit, you can define traffic classes (t-classes) and each traffic class is allocated a percentage of the Frame Relay circuit’s bandwidth. The traffic class support for Frame Relay circuits is analogous to the traffic class support for PPP interfaces. See Figure 2 on page 2 for the Frame Relay Circuit Class and Traffic Class Relationships.

## Using BRS and Priority Queuing

Traffic Class	Percentage of Interface Bandwidth	Priority Queue	Type of Traffic
LOCAL	10%		
DEFAULT	40%	URGENT	(Protocol, Tag, Filter)
		HIGH	(Protocol, Tag, Filter)
		NORMAL	Protocol (Tag, Filter)
CLASS A	xx%	URGENT	(Protocol, Tag, Filter)
		HIGH	(Protocol, Tag, Filter)
		LOW	(Protocol, Tag, Filter)

PPP Connection (BRS [i #])

**Note:** All protocols are initially assigned to the NORMAL priority queue of the DEFAULT traffic class. You can assign a protocol, filter, or tag to any priority queue within a traffic class.

Figure 1. PPP BRS Traffic Class and Traffic Class Priority Queue Relationship

Circuit Class	Bandwidth Percentage	Circuit Number	BRS Filtering	Traffic Class Specification
DEFAULT	40%	16	enabled	using default *
		17	disabled	no traffic filtering
		18	enabled	circuit specific:
				LOCAL 10%
				DEFAULT 40%
				URGENT (protocol, tag, filter) DE **
				HIGH (protocol, tag, filter) DE
				NORMAL protocol (tag, filter) DE
				LOW (protocol, tag, filter) DE
CLASS A	xx%	20		using defaults *
		21		using defaults *
Other circuit class definitions ...				
** Represents that the data is discard eligible				
* Default circuit traffic class definitions (BRS [i #] [Circuit Default] Config>)				
LOCAL	10%			
DEFAULT	40%			URGENT (protocol, tag, filter) DE
				HIGH (protocol, tag, filter) DE
				NORMAL protocol (tag, filter) DE
				LOW (protocol, tag, filter) DE
% of Circuit class allocation for traffic class				

Frame Relay Connection (BRS [i #] Config>)

**Note:** All protocols are initially assigned to the NORMAL priority queue of the DEFAULT traffic class. You can assign a protocol, filter, or tag to any priority queue within a traffic class.

Figure 2. Frame Relay BRS Circuit Class and Traffic Class Relationship

These reserved percentages are a minimum *slice* of bandwidth for the network connection. If a network is operating to capacity, messages in any one class can be transmitted only until they use the configured bandwidth allocated for the class. In

this case, additional transmissions are held until other bandwidth transmissions have been satisfied. In the case of a light traffic path, a packet stream can use bandwidth exceeding its allowed minimum up to 100% if there is no other traffic.

Bandwidth reservation is really a *safeguard*. In general, a device should not attempt to use greater than 100% of its line speed. If it does, a faster line is probably needed. The “bursty” nature of traffic, however, can drive the requested transmission rate to exceed 100% for a short time. In these cases, bandwidth reservation is enabled and the higher priority traffic is ensured delivery (that is, is not discarded).

Bandwidth reservation runs over the following connection types:

- Frame Relay (serial line or dial circuit interface)
- PPP (serial line or dial circuit interface)

---

### Bandwidth Reservation over Frame Relay

Bandwidth reservation allows you to reserve bandwidth at two levels:

- At the interface level, you can assign a percentage of the interface’s bandwidth to circuit classes (*c-classes*). Each circuit class contains one or more circuits.
- At the circuit level, you can define traffic classes (*t-classes*) and allocate a percentage of the circuit’s bandwidth. (A traffic class created by the **create-super-class** command is not associated with any bandwidth but always takes priority over all other t-classes defined for the circuit.)

When BRS receives a packet from Frame Relay, the configured c-classes and t-classes are used to determine when that packet will be transmitted. BRS queues the packet according to these criteria: c-class, circuit, t-class, and priority within the t-class. The c-class to which the circuit has been assigned is put onto a queue of c-classes and the queue of c-classes is sorted according to a fair weighted queuing algorithm. Within a c-class, circuits that have packets to be transmitted are serviced in a round robin fashion. The t-classes within each c-class are also sorted according to a fair weighted queuing algorithm. Within the t-class, packets are further queued according to their priority (urgent, high, normal, or low).

A packet is removed from the queue and transmitted when it meets all these criteria:

1. Is the next packet in the next c-class
2. Is the next packet in the next circuit within the c-class
3. Is one of the packets in the next t-class for that c-class
4. Is the next packet in the next priority group for that t-class

When you enable the interface and one or more circuits for BRS and do not configure any c-classes or t-classes, all the circuits are assigned to one c-class called *default*. With this configuration, there will be only the default c-class on the queue of c-classes and each of the circuits in the c-class with packets for transmission will be handled in a round robin order. If you want BRS to do this, leave all circuits in the default c-class and do not create any other circuit classes.

Orphaned circuits and circuits without BRS explicitly enabled use this default BRS queuing environment in all situations. BRS assigns them to the default c-class.

To configure BRS, you should follow this sequence:

1. Enable BRS on the interface.
2. Enable BRS on the circuits and add the c-classes.

## Using BRS and Priority Queuing

3. Assign the circuits to the c-classes.
4. If desired, define t-classes for each of the c-classes.

You can use several bandwidth reservation monitoring commands to display reservation counters for the circuit classes for a given interface:

- clear-circuit-class
- counters-circuit-class
- last-circuit-class

See “Chapter 2. Configuring and Monitoring Bandwidth Reservation” on page 19 for more information on monitoring BRS.

The interface is the one shown at your prompt for the bandwidth monitoring commands. For example, BRS [i 5] is the prompt for interface 5.

## Queuing Support

With bandwidth reservation over Frame Relay, each circuit can queue frames while in the congested state, even for interfaces and circuits that are not enabled for bandwidth reservation.

## Discard Eligibility

The Frame Relay network may discard transmitted data exceeding CIR on a PVC. The DE bit can be set by the router to indicate that some traffic should be considered discard eligible. If appropriate, the Frame Relay network will discard frames marked as discard eligible, which may allow frames that are not marked discard eligible to make it through the network. When assigning a protocol, filter, or tag to a traffic class, you can specify whether or not the protocol, filter, or tag traffic is discard eligible. See “Assign” on page 25 for more information on how to configure traffic as discard eligible. Voice traffic (identified by the protocol VOFR) should always be configured as **not** discard-eligible.

## Default Circuit Definitions for Traffic Class Handling

Frame Relay interfaces can have many circuits defined. Rather than having to fully configure traffic class definitions for each circuit, BRS allows you to define a default set of traffic classes and protocol, filter, and tag assignments called default circuit definitions that can be used by any circuit on the interface. When BRS is initially enabled on a circuit, the circuit is initialized to use default circuit definitions. If a circuit cannot use the default circuit definitions for traffic class handling then you can create circuit-specific definitions by using the **add-class**, **change-class**, **assign**, **deassign**, **tag**, and **untag** commands.

If a circuit is using circuit specific definitions and you want it to use the default circuit definitions instead, you can use the **use-circuit-defaults** command at the circuit’s BRS prompt.

The default circuit definitions for traffic class handling are defined by using the **set-circuit-defaults** at the BRS Frame Relay interface prompt. This command gets you to a BRS circuit defaults prompt where you can add, change, and delete traffic classes, assign and deassign protocols, filters, and tags, and create BRS tags. Changes to the default circuit definitions for traffic classes result in dynamic updates to the traffic class handling for all circuits using the default circuit definitions.

## Configuring BRS for Voice over Frame Relay

Voice frames can be transported over dedicated circuits. In this situation, enable BRS on the interface and on the circuits and accept the defaults on circuits

associated with voice. You may want to create multiple c-classes and assign the circuits dedicated to voice to a c-class which is associated with a large bandwidth percentage and assign the circuits associated with data to a circuit class associated with a smaller bandwidth percentage.

If voice and other traffic are both transported over the same circuits, enable BRS on the interface and circuits. If you want all circuits serviced in a round robin fashion without favoring one or more circuits you may decide not to create additional c-classes beyond the default c-class. Then, for each circuit over which both voice and data will be transported, it is suggested that you create a t-class with the **create-super-class** command and assign your VOFR traffic to this class. Also create additional t-classes as needed and assign other types of traffic to these t-classes. This configuration will help to ensure that voice traffic gets priority over all other traffic and that unsegmented voice frames can be interleaved between fragmented data segments if fragmentation is enabled. It is recommended that you enable fragmentation on the Frame Relay interface if you will be sending voice and data over the same interface. Fragmentation will result in smaller frames and thus a smaller delay between consecutive voice frames.

Refer to the **enable fragmentation** command in the chapter “Configuring and Monitoring Frame Relay Interfaces” in the *Access Integration Services Software User’s Guide* for more information about enabling fragmentation.

---

## Priority Queuing

Bandwidth reservation allocates percentages of total connection bandwidth for specified traffic *classes*, or *t-classes*, defined by the user. Except for a t-class created by the **create-super-class** command which has priority over all other t-classes, BRS t-classes are associated with a bandwidth percentage. Protocols and filter data can be assigned to t-classes and to specific priority queues within a t-class. With priority queuing, a protocol or filter can be assigned to a specific queue within a traffic class with settings: A BRS t-class is a group of packets identified by the same name; for example, a class called “ipx” to designate all IPX packets.

With priority queuing, each bandwidth t-class can be assigned one of the following priority level settings:

- Urgent
- High
- Normal (the default setting)
- Low

for specified traffic classes, or t-classes, defined by the user.

Also, you can set the number of packets that are waiting in the queue for each priority level in each bandwidth t-class. The BRS **queue-length** command sets the maximum number of output buffers that can be queued in each BRS priority queue, and the maximum number of output buffers that can be queued in each BRS priority queue for when router input buffers are scarce. You can set up priority queue lengths for both PPP and Frame Relay.

**Attention:** If you set the values for queue length too high, you may seriously degrade the performance of your router.

For BRS, you can set priority queue lengths for PPP and Frame Relay WAN connections. See “Queue-length” on page 37 for a description of the **queue-length** command.

## Using BRS and Priority Queuing

The priority settings in one bandwidth t-class have no effect on other bandwidth classes. No one bandwidth class has priority over the others.

## Priority Queuing Without Bandwidth Reservation

When priority queuing is configured without bandwidth reservation, the highest priority traffic is delivered first. In instances of heavy high-priority traffic, lower priority levels can be overlooked. By combining priority queuing with bandwidth reservation, however, packet transmission can be allocated to all types of traffic.

## Configuring Traffic Classes

You create a traffic class using the **add-class** command and then assign types of traffic to the class using the **assign** command. Traffic is assigned to a traffic class based on its *protocol type* or based on a filter that further identifies a specific type of *protocol traffic* (for example, SNMP IP packets).

Supported protocol types are:

- IP
- ARP
- DNA
- VINES
- IPX
- OSI
- VOFR
- AP2
- ASRT
- SNA/APPN-ISR
- APPN-HPR<sup>®</sup>
- HPR/IP

### BRS Filters

Using bandwidth reservation, you can treat specific protocol traffic differently from other traffic that is using the same protocol type. For example, you can assign SNMP IP traffic to a different traffic class and priority than other IP traffic. In this example, SNMP is a BRS filter because it *filters* (that is, uniquely identifies) specific protocol traffic. IP, ASRT (bridging) and APPN-HPR protocol traffic can be filtered by bandwidth reservation. The following filters are supported:

- IP tunneling
- SDLC tunneling over IP (SDLC Relay)
- BSC tunneling over IP (BSC Relay)
- Rlogin
- Telnet
- SNA/APPN-ISR
- APPN-HPR
- SNMP
- IP Multicast
- DLSw
- MAC Filter
- NetBIOS
- Network-HPR
- High-HPR
- Medium-HPR
- Low-HPR
- XTP
- TCP/UDP port numbers or sockets
- TOS byte



- precedence bit

---

## BRS and Filtering

The following sections describe how to use BRS with various types of filtering.

### MAC Address Filtering and Tags

MAC Address filtering is handled by a joint effort between bandwidth reservation and MAC filtering (MCF) using *tags*. For example, a user with bandwidth reservation is able to categorize bridge traffic by assigning a tag to it.

The tagging process is done by creating a filter item in the MAC filtering configuration console and then assigning a tag number to it. This tag number is used to set up a traffic class for all packets associated with this tag. Tag values must currently be in the range 1 through 64. See “Chapter 3. Using MAC Filtering” on page 47 for additional information about MAC filtering.

**Note:** Tags can be applied *only* to bridged packets. On a PPP or Frame Relay connection, up to five tagged MAC filters can be assigned as bandwidth reservation filters and are designated as TAG1 through TAG5. TAG1 is searched for first, then TAG2, and so on up to TAG5. A single MAC filter tag can consist of any number of MAC Addresses set in MCF.

Once you have created a tagged filter in the MAC filtering configuration process, you can use the BRS tag configuration command to assign a BRS tag name (TAG1, TAG2, TAG3, TAG4, or TAG5) to the MAC filter tag number. Then use the BRS tag name on the BRS assign command to assign the corresponding MAC filter to a bandwidth traffic class and priority.

Tags also can refer to “groups,” as in the example of IP Tunnel. IP Tunnel endpoints can belong to any number of groups. Packets are assigned to a particular group through the tagging feature of MAC Address filtering. For additional information on MAC filtering, refer to “Chapter 3. Using MAC Filtering” on page 47 and “Chapter 4. Configuring and Monitoring MAC Filtering” on page 51.

To apply bandwidth reservation and queuing priority to tagged packets:

1. Use the MAC filtering configuration commands at the `filter config>` prompt to set up tags for packets passing through the bridge. Refer to “Chapter 3. Using MAC Filtering” on page 47 for more information.
2. Use the bandwidth reservation **tag** command to reference a tag for bandwidth reservation.
3. With the bandwidth reservation **assign** command, assign the BRS tag to a t-class. The **assign** command also prompts you for a queuing priority within that BRS t-class.

### TCP/UDP Port Number Filtering

You can assign TCP/IP packets from a range of TCP or UDP ports to a BRS t-class and priority based on the packet’s UDP or TCP port number and, optionally, upon a socket. You can specify up to 5 UDP/TCP port number filters, where the filters specify either an individual TCP or UDP port number, a range of TCP or UDP port numbers, or a socket identifier (combination of port number and IP address). You can then assign that filter to a BRS traffic class and priority within the class.

## Using BRS and Priority Queuing

If UDP/TCP port filtering is enabled, BRS looks at each TCP or UDP packet and checks to see if the destination or source port number matches one of the port numbers you have specified for filtering. Also, if you define an IP address as part of the BRS UDP/TCP filter and the destination or source IP address matches the filter address you define, BRS assigns the packet to the traffic class and priority for that port number filter.

For example, you can configure a UDP port number filter for UDP port numbers in the range 25 to 29 and assign the filter to traffic class 'A' with a priority of 'normal'. BRS queues any UDP packets with a source or destination port number from 25 to 29 on the normal priority queue for traffic class 'A'.

You can also configure a TCP port number filter for TCP port number 50 for IP address 5.5.5.25 and assign the filter to traffic class 'B' with priority 'urgent'. BRS queues any TCP packets whose source or destination port number is 50 and whose destination or source IP address is 5.5.5.25 on the urgent priority queue for traffic class 'B'.

## IPv4 TOS Bit Filtering

You can create filters that will distinguish different types of IP traffic based upon the settings of the Type of Service (TOS) bits. These TOS filters can be used to assign IPv4 traffic that has particular settings of the TOS bits to a different class and priority than other types of IP traffic. Each filter allows IPv4 traffic whose TOS byte value matches the definition of a configured TOS filter to be assigned a unique traffic class and priority. Configuration of a TOS filter includes a mask value specification to define which bits within the TOS byte are to be matched as well as specification of low and high range values for bits that fall within the mask. The filtering mechanism is based solely on IPv4 TOS values; therefore, it does not rely on identification of IPv4 protocol type or port number information as do most of the other IP filters.

This filter is more expansive in its application than BRS IPv4 precedence filtering, which is concerned only with the high-order 3 bits of the TOS byte. When combined with IP access control support to set TOS bits, BRS TOS bit filter support enables you to perform filtering for traffic that is sent over a secure tunnel, that is fragmented, or that cannot be identified using the BRS UDP and TCP port number filter support. Also, IP access control support allows you to set the TOS bits to a user-defined value instead of having to use the hard-coded precedence bit values for APPN and DLSw that are associated with BRS IPv4 precedence bit filtering. Therefore, it is recommended that you use IP access control and BRS TOS filter support instead of BRS IPv4 precedence bit filtering.

As indicated in "Order of Filtering Precedence" on page 11, TOS filter matches are checked prior to IPv4 precedence bit filters and other IP-specific filters. Checks for the TOS1 to TOS5 filter matches are done sequentially, beginning with the TOS1 filter. Up to 5 TOS filters can be defined.

**Important:** Keep in mind that a packet with a particular TOS value is handled according to the first TOS filter definition that the value matches. Be careful to set up your filters so that a particular TOS byte is filtered by the intended filter, not accidentally filtered by a lower-numbered filter. Refer to "Using IP" in *Using and Configuring Features* for more information.

## Using IP Version 4 Precedence Bit Processing for SNA Traffic in IP Secure Tunnels and Secondary Fragments

BRS normally differentiates IP TCP and UDP traffic according to its port numbers. However, BRS cannot identify the ports after traffic has been encapsulated twice, such as IP traffic transported through an IP secure tunnel or in a secondary UDP or TCP fragment. IP version 4 precedence bit processing has been added to BRS to enable BRS to filter IP secure tunnel packets or TCP and UDP secondary fragment packets.

**Note:** It is recommended that you use BRS IPv4 TOS bit filtering instead of IPv4 precedence bit processing. See “IPv4 TOS Bit Filtering” on page 8 for more details.

When APPN/HPR traffic is being routed over IP, each transmission priority of APPN-HPR (network, high, medium, and low) is mapped to a particular value of the three IP version 4 precedence bits.

- The HPR network transmission priority maps to the IPv4 precedence value of '110'b.
- The HPR high transmission priority maps to the IPv4 precedence value of '100'b.
- The HPR medium transmission priority maps to the IPv4 precedence value of '010'b.
- The HPR low transmission priority maps to the IPv4 precedence value of '001'b.

When IPv4 precedence filtering is enabled for BRS and the precedence bits in an IP packet match one of the values used for APPN/HPR traffic, then the packet is queued on the priority queue of the BRS t-class to which the corresponding HPR transmission priority is assigned. For example, if an IP packet has a precedence value of '110'b and the BRS HPR-Network filter is assigned to t-class A and priority level normal, then the packet is queued on the normal priority queue of t-class A. If a BRS HPR transmission priority filter is not configured, but the APPN-HPR filter is configured, then the packet is queued on the priority queue and t-class to which the APPN-HPR filter is assigned.

These three kinds of traffic map to the IPv4 precedence value '011'b:

- APPN/HPR XID traffic that is sent when APPN/HPR is routed over IP
- DLSw traffic
- TN3270 traffic

Because several types of traffic map to one value, BRS cannot distinguish between them when it is enabled to filter based on the IPv4 precedence bits. Therefore, when BRS encounters an IP packet with a precedence value of '011'b, it evaluates the BRS filters in the following order to determine whether or not the filter is enabled. When it finds a BRS filter that is configured, the packet is queued on the priority queue and t-class to which the BRS filter is assigned:

- SNA/APPN-ISR (used for APPN/HPR XID exchanges)
- DLSw
- Telnet

If a packet has one of the precedence values that are filtered by BRS, but none of the applicable BRS filter types are configured, the packet is queued on the priority queue and the BRS t-class to which the IP protocol is assigned.

When TN3270 traffic is sent by a client to the 2212 over a wide-area network where BRS is enabled, traffic from the client cannot be prioritized by BRS unless the client sets the precedence bits to '011'b.

## Using BRS and Priority Queuing

You must configure IPv4 precedence bit handling in multiple places:

1. In BRS you configure whether or not BRS should filter based on the IPv4 precedence bits. It only performs this type of filtering for IP secure tunnel packets or TCP and UDP secondary fragment packets.
2. When you configure DLSw, HPR over IP, and TN3270, you specify whether or not the 2212 should set the IPv4 precedence bits for packets that it originates for each of these protocol types.

Perform these three steps to use IPv4 precedence bit filtering:

1. Activate IPv4 precedence filtering in BRS.
2. Configure BRS t-classes and assign protocols and filters for various categories of SNA traffic, as you would for SNA traffic that is not transported in an IP secure tunnel or is not fragmented.
3. Enable the setting of the IPv4 precedence bits when configuring the DLSw, HPR over IP, and TN3270 protocols.
4. Configure IPSec to create a secure tunnel over which the DLSw, HPR over IP, and TN3270 traffic will flow.

## SNA and APPN Filtering for Bridged Traffic

The SNA/APPN-ISR filter allows you to assign SNA and APPN-ISR traffic that is being bridged to a BRS traffic class. SNA and APPN-ISR traffic is identified as any bridged packets with a destination or source SAP of 0x04, 0x08, or 0x0C and whose LLC (802.2) control field indicates that it is not an unnumbered information (UI) frame.

**Note:** Frame Relay BAN packets are in this category.

The APPN-HPR filters allow you to assign HPR traffic that is being bridged to a BRS t-class. HPR traffic is identified as any bridge packet with a destination or source SAP of X'04', X'08', X'0C', or X'C8' and whose LLC (802.2) control field indicates it is an unnumbered information (UI) frame.

The Network-HPR, High-HPR, Medium-HPR, and Low-HPR filters allow HPR bridge traffic to further be filtered according to the HPR transmission priority. For example, if you want to assign HPR traffic that uses the network transmission priority to one t-class and priority and all other HPR bridged traffic to a different t-class or priority, you would assign the Network-HPR filter to the appropriate t-class and priority and use the APPN-HPR filter to assign the rest of the HPR traffic to a different t-class or priority.

APPN-HPR traffic that is being routed over IP is filtered using the UDP port number assigned for network, high, medium and low HPR transmission priorities. An additional UDP port number is used for XID exchanges. All of the UDP port numbers used to support APPN-HPR over IP are configurable.

If APPN is not enabled in an intermediate router in the IP network, you can configure UDP port numbers for HPR over IP from the BRS Config> command prompt. If APPN is enabled in the device, BRS will use the values configured at the APPN Config> command prompt.

Other filters may help you to assign traffic. For example, the DLSw filter allows you to assign SNA-DLSw traffic that is being sent over a TCP connection to a BRS t-class.

For SNA/APPN-ISR and APPN-HPR filters, if you want to check for SAPs other than the ones above, create a sliding window filter using MAC filtering and tag that filter. Then assign the tagged MAC filter to a BRS t-class.

### Order of Filtering Precedence

It is possible for a packet to match more than one BRS filter type. For example, an IP tunneled bridge packet containing SNA data could match the IP tunneling filter and the SNA/APPN-ISR filter. The order in which the filters are evaluated to determine whether or not a packet matches a BRS filter type is as follows:

1. TOS filters (IP)
2. IPv4 precedence handling
3. MAC filter tag match for bridging packets (IP/ASRT)
4. NetBIOS for bridging (IP/ASRT)
5. SNA/APPN-ISR for bridging (IP/ASRT)
6. HPR-Network (IP/ASRT/APPN-HPR)
7. HPR-High (IP/ASRT/APPN-HPR)
8. HPR-Medium (IP/ASRT/APPN-HPR)
9. HPR-Low (IP/ASRT/APPN-HPR)
10. APPN-HPR (IP/ASRT)
11. UDP/TCP port number filters (IP)
12. IP tunneling (IP)
13. SDLC/BSC relay (IP)
14. DLSw (IP)
15. Multicast (IP)
16. SNMP (IP)
17. Rlogin (IP)
18. Telnet (IP)
19. XTP (IP)

**Note:** The protocols for which a filter applies are shown in parentheses.

---

## Sample Configurations

### Using Default Circuit Definitions for Traffic Class Handling of Frame Relay Circuits

#### Notes:

- 1** Configure feature BRS.
- 2** Enable BRS on interface 1.
- 3** Enable BRS on circuits 16, 17, 18. Default circuit definitions for traffic class handling are used for these circuits.
- 4** Access the set-circuit-defaults menu to define default circuit definitions for traffic class handling.
- 5** Add traffic classes and assign protocols and filters to the traffic classes.
- 6** List and show the BRS definitions for circuit 16. Since circuit 16 is using default circuit definitions, the traffic classes and protocol and filter assignments defined by the default circuit definitions are displayed.
- 7** Change circuit 17 from using default circuit definitions to use circuit-specific definitions for traffic class handling by creating a unique class, CIRC171. This class can have protocols, filters, or tags assigned to it.
- 8** Change the default circuit definitions such that the DEF1 and DEF2 traffic classes each reserve 10% of the bandwidth and then show that

## Using BRS and Priority Queuing

these changes are picked up by circuit 16 but not by circuit 17, since circuit 17 is now using circuit-specific definitions.

**9** Alter circuit 17 to use default circuit definitions for traffic class handling instead of circuit-specific definitions.

```
t 6
Gateway user configuration
Config>feature brs 1
Bandwidth Reservation User Configuration
BRS Config>interface 1 2
BRS [i 1]Config>enable
Please restart router for this command to take effect.
BRS [i 1] Config>circuit 16 3
BRS [i 1][dlci 16] Config>enable
Defaults are in effect for this circuit.
Please restart router for this command to take effect.
BRS [i 1][dlci 16] Config>exit
BRS [i 1]Config>circuit 17
BRS [i 1][dlci 17] Config>enable
Defaults are in effect for this circuit.
Please restart router for this command to take effect.
BRS [i 1][dlci 17] Config>exit
BRS [i 1]Config>circuit 18
BRS [i 1][dlci 18] Config>enable
Defaults are in effect for this circuit.
Please restart router for this command to take effect.
BRS [i 1][dlci 18] Config>
*restart
Are you sure you want to restart the gateway? (Yes or [No]): yes

*t 6
Gateway user configuration
Config>feature brs
Bandwidth Reservation User Configuration
BRS Config>interface 1
BRS[i 1] Config>list

BANDWIDTH RESERVATION listing from SRAM
bandwidth reservation is enabled
interface number 1
maximum queue length 10, minimum queue length 3
total bandwidth allocated 10%
total circuit classes defined (counting one default) 1

class DEFAULT has 10% bandwidth allocated
the following circuits are assigned:
    16 using defaults.
    17 using defaults.
    18 using defaults.

default class is DEFAULT

BRS [i 1] Config>?
ENABLE
DISABLE
SET-CIRCUIT-DEFAULTS
CIRCUIT
ADD-CIRCUIT-CLASS
DEL-CIRCUIT-CLASS
CHANGE-CIRCUIT-CLASS
DEFAULT-CIRCUIT-CLASS
ASSIGN-CIRCUIT
DEASSIGN-CIRCUIT
QUEUE-LENGTH
LIST
SHOW
CLEAR-BLOCK
EXIT
BRS [i 1] Config>set-circuit-defaults 4
BRS [i 1] [circuit defaults] Config>?
ADD-CLASS
DEL-CLASS
CHANGE-CLASS
DEFAULT-CLASS
```

```

TAG
UNTAG
ASSIGN
DEASSIGN
LIST
EXIT
BRS [i 1] [circuit defaults] Config>add 5
Class name [DEFAULT]?DEF1
Percent bandwidth to reserve [10]? 5
BRS [i 1] [circuit defaults] Config>add
Class name [DEFAULT]?DEF2
Percent bandwidth to reserve [10]?5
BRS [i 1] [circuit defaults] Config>assign ip
Class name [DEFAULT]?DEF1
Priority <URGENT/HIGH/NORMAL/LOW> [NORMAL]?
Frame Relay Discard Eligible <NO/YES> [NO]?
BRS [i 1] [circuit defaults] Config>assign asrt
Class name [DEFAULT]? DEF2
Priority <URGENT/HIGH/NORMAL/LOW> [NORMAL]?
Frame Relay Discard Eligible <NO/YES> [NO]?
BRS[i 1] [circuit defaults] Config>list

BANDWIDTH RESERVATION listing from SRAM
bandwidth reservation is enabled
interface number 1, default circuit
total bandwidth allocated 60%
total classes defined (counting one local and one default) 4

class LOCAL has 10% bandwidth allocated
  protocols and filters cannot be assigned to this class.

class DEFAULT has 40% bandwidth allocated
  the following protocols and filters are assigned:
    protocol ARP with default priority is not discard eligible
    protocol DNA with default priority is not discard eligible
    protocol VINES with default priority is not discard eligible
    protocol IPX with default priority is not discard eligible
    protocol OSI with default priority is not discard eligible
    protocol VOFR with default priority is not discard eligible
    protocol AP2 with default priority is not discard eligible

class DEF1 has 5% bandwidth allocated
  the following protocols and filters are assigned:
    protocol IP with priority NORMAL is not discard eligible

class DEF2 has 5% bandwidth allocated
  the following protocols and filters are assigned:
    protocol ASRT with priority NORMAL is not discard eligible

assigned tags:

default class is DEFAULT with priority NORMAL

BRS [i 1] [circuit defaults] Config>exit
BRS [i 1] Config>circuit 16 6
BRS [i 1][dlci 161] Config>list

BANDWIDTH RESERVATION listing from SRAM
bandwidth reservation is enabled
interface number 1, circuit number 16 using defaults.
maximum queue length 10, minimum queue length 3
total bandwidth allocated 60%
total classes defined (counting one local and one default) 4

class LOCAL has 10% bandwidth allocated
  protocols and filters cannot be assigned to this class.

class DEFAULT has 40% bandwidth allocated
  the following protocols and filters are assigned:
    protocol ARP with default priority is not discard eligible
    protocol DNA with default priority is not discard eligible
    protocol VINES with default priority is not discard eligible
    protocol IPX with default priority is not discard eligible
    protocol OSI with default priority is not discard eligible

```

## Using BRS and Priority Queuing

```
protocol VOFR with default priority is not discard eligible
protocol AP2 with default priority is not discard eligible

class DEF1 has 5% bandwidth allocated
the following protocols and filters are assigned:
protocol IP with priority NORMAL is not discard eligible

class DEF2 has 5% bandwidth allocated
the following protocols and filters are assigned:
protocol ASRT with priority NORMAL is not discard eligible

assigned tags:

default class is DEFAULT with priority NORMAL
```

```
BRS [i 1] [dlci 16] Config>show
```

```
BANDWIDTH RESERVATION currently in RAM
interface number 1, circuit number 16 using defaults.
maximum queue length 10, minimum queue length 3
4 current defined classes:
class LOCAL has 10% bandwidth allocated
class DEFAULT has 40% bandwidth allocated
class DEF1 has 5% bandwidth allocated
class DEF2 has 5% bandwidth allocated
```

```
protocol and filter assignments:
```

Protocol/Filter	Class	Priority	Discard Eligible
IP	DEF1	NORMAL	NO
ARP	DEFAULT	NORMAL	NO
DNA	DEFAULT	NORMAL	NO
VINES	DEFAULT	NORMAL	NO
IPX	DEFAULT	NORMAL	NO
OSI	DEFAULT	NORMAL	NO
VOFR	DEFAULT	NORMAL	NO
AP2	DEFAULT	NORMAL	NO
ASRT	DEF2	NORMAL	NO

```
BRS [i 1] [dlci 16] Config>exit
```

```
BRS [i 1] Config>circuit 17
BRS [i 1] [dlci 17] Config>list
```

```
BANDWIDTH RESERVATION listing from SRAM
bandwidth reservation is enabled
interface number 1, circuit number 17 using defaults.
maximum queue length 10, minimum queue length 3
total bandwidth allocated 60%
total classes defined (counting one local and one default) 4
```

```
class LOCAL has 10% bandwidth allocated
protocols and filters cannot be assigned to this class.
```

```
class DEFAULT has 40% bandwidth allocated
the following protocols and filters are assigned:
protocol ARP with default priority is not discard eligible
protocol DNA with default priority is not discard eligible
protocol VINES with default priority is not discard eligible
protocol IPX with default priority is not discard eligible
protocol OSI with default priority is not discard eligible
protocol VOFR with default priority is not discard eligible
protocol AP2 with default priority is not discard eligible
```

```
class DEF1 has 5% bandwidth allocated
the following protocols and filters are assigned:
protocol IP with priority NORMAL is not discard eligible
```

```
class DEF2 has 5% bandwidth allocated
the following protocols and filters are assigned:
protocol ASRT with priority NORMAL is not discard eligible
```

```
assigned tags:
```



## Using BRS and Priority Queuing

default class is DEFAULT with priority NORMAL

```
BRS [i 1] [dlci 17] Config>add-class 7
This circuit is currently using circuit defaults...
Are you sure you want to override the defaults?(Yes or [No]): yes
Class name [DEFAULT]? CIRC171
Percent bandwidth to reserve [10]? 5
BRS[i 1] [dlci 17] Config>assign vines
Class name [DEFAULT]? CIRC171
Priority <URGENT/HIGH/NORMAL/LOW> [NORMAL]?
Frame Relay Discard Eligible <NO/YES>[NO]?
```

```
BRS [i 1] [dlci 17] Config>list
```

```
BANDWIDTH RESERVATION listing from SRAM
bandwidth reservation is enabled
interface number 1, circuit number 17
maximum queue length 10, minimum queue length 3
total bandwidth allocated 65%
total classes defined (counting one local and one default) 5
```

```
class LOCAL has 10% bandwidth allocated
protocols and filters cannot be assigned to this class.
```

```
class DEFAULT has 40% bandwidth allocated
the following protocols and filters are assigned:
protocol ARP with default priority is not discard eligible
protocol DNA with default priority is not discard eligible
protocol IPX with default priority is not discard eligible
protocol OSI with default priority is not discard eligible
protocol VOFR with default priority is not discard eligible
protocol AP2 with default priority is not discard eligible
```

```
class DEF1 has 5% bandwidth allocated
the following protocols and filters assigned:
protocol IP with priority NORMAL is not discard eligible
```

```
class DEF2 has 5% bandwidth allocated
the following protocols and filters are assigned:
protocol ASRT with priority NORMAL is not discard eligible
```

```
class CIRC171 has 5% bandwidth allocated
the following protocols and filters are assigned:
protocol VINES with priority NORMAL is not discard eligible
```

assigned tags:

default class is DEFAULT with priority NORMAL

```
BRS [i 1] [dlci 17] Config>show
```

```
BANDWIDTH RESERVATION currently in RAM
interface number 1, circuit number 17
maximum queue length 10, minimum queue length 3
5 current defined classes:
class LOCAL has 10% bandwidth allocated
class DEFAULT has 40% bandwidth allocated
class DEF1 has 5% bandwidth allocated
class DEF2 has 5% bandwidth allocated
class CIRC171 has 5% bandwidth allocated
```

protocol and filter assignments:

Protocol/Filter	Class	Priority	Discard Eligible
IP	DEF1	NORMAL	NO
ARP	DEFAULT	NORMAL	NO
DNA	DEFAULT	NORMAL	NO
VINES	CIRC171	NORMAL	NO
IPX	DEFAULT	NORMAL	NO
OSI	DEFAULT	NORMAL	NO
VOFR	DEFAULT	NORMAL	NO

## Using BRS and Priority Queuing

```
AP2          DEFAULT          NORMAL          NO
ASRT         DEF2             NORMAL          NO

BRS [i 1] [dlci 17] Config>exit
BRS [i 1] Config>set-circuit-defaults
BRS [i 1] [circuit defaults] Config>change DEF1 8
Percent bandwidth to reserve [ 5]? 10
BRS [i 1] [circuit defaults] Config>change DEF2
Percent bandwidth to reserve [5]? 10
BRS [i 1] [circuit defaults] Config>list

BANDWIDTH RESERVATION listing from SRAM
bandwidth reservation is enabled
interface number 1, default circuit
total bandwidth allocated 70%
total classes defined (counting one local and one default) 4

class LOCAL has 10% bandwidth allocated
  protocols and filters cannot be assigned to this class.

class DEFAULT has 40% bandwidth allocated
  the following protocols and filters are assigned:
    protocol ARP with default priority is not discard eligible
    protocol DNA with default priority is not discard eligible
    protocol VINES with default priority is not discard eligible
    protocol IPX with default priority is not discard eligible
    protocol OSI with default priority is not discard eligible
    protocol VOFR with default priority is not discard eligible
    protocol AP2 with default priority is not discard eligible

class DEF1 has 10% bandwidth allocated
  the following protocols and filters are assigned:
    protocol IP with priority NORMAL is not discard eligible

class DEF2 has 10% bandwidth allocated
  the following protocols and filters are assigned:
    protocol ASRT with priority NORMAL is not discard eligible

assigned tags:

default class is DEFAULT with priority NORMAL

BRS [i 1] [circuit defaults] Config>exit

BRS [i 1] Config>circuit 16
BRS [i 1] [dlci 16] Config>list

BANDWIDTH RESERVATION listing from SRAM
bandwidth reservation is enabled
interface number 1, circuit number 16 using defaults.
maximum queue length 10, minimum queue length 3
total bandwidth allocated 70%
total classes defined (counting one local and one default) 4

class LOCAL has 10% bandwidth allocated
  protocols and filters cannot be assigned to this class.

class DEFAULT has 40% bandwidth allocated
  the following protocols and filters are assigned:
    protocol ARP with default priority is not discard eligible
    protocol DNA with default priority is not discard eligible
    protocol VINES with default priority is not discard eligible
    protocol IPX with default priority is not discard eligible
    protocol OSI with default priority is not discard eligible
    protocol VOFR with default priority is not discard eligible
    protocol AP2 with default priority is not discard eligible

class DEF1 has 10% bandwidth allocated
  the following protocols and filters are assigned:
    protocol IP with priority NORMAL is not discard eligible

class DEF2 has 10% bandwidth allocated
  the following protocols and filters are assigned:
```

## Using BRS and Priority Queuing

```
protocol ASRT with priority NORMAL is not discard eligible
assigned tags:
default class is DEFAULT with priority NORMAL
BRS [i 1] [dlci 16] Config>exit

BRS [i 1] Config>circuit 17
BRS [i 1] [dlci 17] Config>list

BANDWIDTH RESERVATION listing from SRAM
bandwidth reservation is enabled
interface number 1, circuit number 17
maximum queue length 10, minimum queue length 3
total bandwidth allocated 65%
total classes defined (counting one local and one default) 5

class LOCAL has 10% bandwidth allocated
protocols and filters cannot be assigned to this class.

class DEFAULT has 40% bandwidth allocated
the following protocols and filters are assigned:
protocol ARP with default priority is not discard eligible
protocol DNA with default priority is not discard eligible
protocol IPX with default priority is not discard eligible
protocol OSI with default priority is not discard eligible
protocol VOFR with default priority is not discard eligible
protocol AP2 with default priority is not discard eligible

class DEF1 has 5% bandwidth allocated
the following protocols and filters are assigned:
protocol IP with priority NORMAL is not discard eligible

class DEF2 has 5% bandwidth allocated
the following protocols and filters are assigned:
protocol ASRT with priority NORMAL is not discard eligible

class CIRC171 has 5% bandwidth allocated
the following protocols and filters are assigned:
protocol VINES with priority NORMAL is not discard eligible

assigned tags:
default class is DEFAULT with priority NORMAL

BRS [i 1] [dlci 17] Config>use-circuit-defaults 9
This circuit is currently NOT using circuit defaults...
Are you sure you want to delete current definitions and use defaults ? (Yes or
[No]): yes
Defaults are in effect for this circuit.
Please restart router for this command to take effect.
BRS [i 1] [dlci 17] Config>
*restart
Are you sure you want to restart the gateway? (Yes or [No] ):yes

*t 6
Gateway user configuration
Config>feature brs
Bandwidth Reservation User Configuration
BRS Config>interface 1
BRS [i 1] Config>circuit 17
BRS [i 1] [dlci 17] Config>list

BANDWIDTH RESERVATION listing from SRAM
bandwidth reservation is enabled
interface number 1, circuit number 17 using defaults.
maximum queue length 10, minimum queue length 3
total bandwidth allocated 70%
total classes defined (counting one local and one default) 4

class LOCAL has 10% bandwidth allocated
protocols and filters cannot be assigned to this class.
```

## Using BRS and Priority Queuing

```
class DEFAULT has 40% bandwidth allocated
  the following protocols and filters are assigned:
    protocol ARP with default priority is not discard eligible
    protocol DNA with default priority is not discard eligible
    protocol VINES with default priority is not discard eligible
    protocol IPX with default priority is not discard eligible
    protocol OSI with default priority is not discard eligible
    protocol VOFR with default priority is not discard eligible
    protocol AP2 with default priority is not discard eligible

class DEF1 has 10% bandwidth allocated
  the following protocols and filters are assigned:
    protocol IP with priority NORMAL is not discard eligible

class DEF2 has 10% bandwidth allocated
  the following protocols and filters are assigned:
    protocol ASRT with priority NORMAL is not discard eligible

assigned tags:

default class is DEFAULT with priority NORMAL
```

```
BRS [i 1] [d1ci 17] Config>show
```

```
BANDWIDTH RESERVATION currently in RAM
interface number 1, circuit number 17 using defaults.
maximum queue length 10, minimum queue length 3
4 current defined classes:
  class LOCAL has 10% bandwidth allocated
  class DEFAULT has 40% bandwidth allocated
  class DEF1 has 10% bandwidth allocated
  class DEF2 has 10% bandwidth allocated
```

```
protocol and filter assignments:
```

Protocol/Filter	Class	Priority	Discard Eligible
-----	----	-----	-----
IP	DEF1	NORMAL	NO
ARP	DEFAULT	NORMAL	NO
DNA	DEFAULT	NORMAL	NO
VINES	DEFAULT	NORMAL	NO
IPX	DEFAULT	NORMAL	NO
OSI	DEFAULT	NORMAL	NO
VOFR	DEFAULT	NORMAL	NO
AP2	DEFAULT	NORMAL	NO
ASRT	DEF2	NORMAL	NO

```
BRS [i 1] [d1ci 17] Config>exit
```

---

## Chapter 2. Configuring and Monitoring Bandwidth Reservation

This chapter describes the Bandwidth Reservation System (BRS) configuration and operational commands.

This chapter includes the following sections:

- “Bandwidth Reservation Configuration Overview”
- “Bandwidth Reservation Configuration Commands” on page 20
- “Accessing the Bandwidth Reservation Monitoring Prompt” on page 40
- “Bandwidth Reservation Monitoring Commands” on page 40
- “Bandwidth Reservation Dynamic Reconfiguration Support” on page 43

---

### Bandwidth Reservation Configuration Overview

To access bandwidth reservation configuration commands and configure bandwidth reservation on your router:

1. At the OPCON (\*) prompt, enter **talk 6**.
2. At the Config> prompt, enter **feature brs**.
3. At the BRS Config> prompt, enter **interface #**. The interface must be a point-to-point or Frame Relay interface. BRS cannot be configured on Frame Relay subinterfaces. See “Using Frame Relay Interfaces” in *Access Integration Services Software User’s Guide* for more information.
4. At the BRS [i 0] Config> prompt, enter **enable**.

This is the interface prompt level, and the interface number is zero in this instance. You need to repeat step 3 and step 4 for each interface you are configuring.

If you are configuring BRS on a Frame Relay interface, continue with step 4a:

If you are configuring BRS on any other interface, go directly to step 5.

- a. At the BRS [i 0] Config> prompt, enter **circuit #**, where # is the number of the circuit you want to configure.
  - b. At the BRS [i 0] [dlci 16] Config> prompt, enter **enable**. This is the circuit prompt level and the circuit (DLCI) number is 16 in this instance.
  - c. At the BRS [i 0] [dlci 16] Config> prompt, enter **exit** to return to the interface level prompt.
  - d. Repeat steps 4a through 4c for each circuit for which you want to define BRS t-classes.
5. Restart your router.
  6. Repeat steps 1 through 3 to configure bandwidth reservation for the particular interface that you have enabled.
  7. If you are configuring BRS on a PPP interface, at the BRS[i 0]Config> prompt, configure traffic classes and assign protocols, filters, and tags to the traffic classes using the configuration commands listed in Table 3 on page 22. If you are configuring BRS on a FR interface, follow steps 8 through 10.
  8. If you are configuring BRS on a FR interface, you can configure circuit classes and assign circuits to circuit classes using the commands listed in Table 2 on page 21
  9. If you want to use default circuit definitions then enter the **set-circuit-defaults** command at the BRS[i 0]Config> prompt. This gets you to the BRS[i 0] [circuit defaults] prompt where you can use the appropriate commands from Table 3 on page 22 to configure traffic classes and assign protocols, filters,

## Configuring BRS

and tags to the traffic classes. Once you are through defining default circuit definitions for traffic class handling, enter "exit" to return to the BRS[i 0] Config> prompt.

10. If you have FR circuits that cannot use default circuit definitions for traffic class handling, enter **circuit permanent-virtual-circuit circuit\_number**. This will access the circuit prompt where you can use the commands listed in Table 3 on page 22 to create circuit-specific definitions for traffic class handling.

**Note:** You do not need to restart the router for t-class and c-class configuration changes to take effect.

The **talk 6 (t 6)** command lets you access the configuration process.

The **feature brs** command lets you access the BRS configuration process. You can enter this command by using either the feature name (brs) or number (1).

The **interface #** command selects the particular interface that you want to configure for bandwidth reservation. Before configuring any BRS classes, you must use the **enable** command to enable BRS on the interface. In Step 4 on page 19, the prompt indicates that the selected interface's number is zero.

The **circuit #** command selects the circuit on the FR interface on which you want to configure BRS traffic classes. Before configuring any BRS t-classes for the circuit, you must use the **enable** command to enable BRS on the circuit. In step 4b on page 19, the prompt indicates that circuit 16 on interface 0 has been selected.

You must enable bandwidth reservation for the selected interface and circuit and then restart your router before configuring circuit classes (Frame Relay only), and traffic classes.

To return to the Config> prompt at any time, enter the **exit** command at the different levels of BRS prompts until you are at the Config> prompt.

---

## Bandwidth Reservation Configuration Commands

This section describes the Bandwidth Reservation configuration commands. The commands that can be used differ depending on the BRS configuration prompt that is displayed (BRS Config>, BRS [i x] Config>, or BRS [i x] [dlci y] Config>, or BRS [i x] [circuit defaults] Config>).

*Table 1. Bandwidth Reservation Configuration Command Summary (Available from BRS Config> prompt)*

Command	Function
? (Help)	Displays all the commands available for this command level or lists the options for specific commands (if available). See "Getting Help" on page xxxii.
Activate-IP-precedence-filtering	Activates BRS IPv4 precedence filtering of APPN and SNA packets that are sent over a secure IP tunnel or that are in secondary TCP or UDP fragments. You also must configure the setting of the IPv4 precedence bits when you configure DLSw, HPR over IP or TN3270.
Deactivate-IP-precedence-filtering	Deactivates IPv4 precedence filtering processing.

## Configuring BRS and Priority Queuing

Table 1. Bandwidth Reservation Configuration Command Summary (Available from BRS Config> prompt) (continued)

Command	Function
Enable-hpr-over-ip-port-numbers	Enables the use of BRS filtering for APPN-HPR over IP traffic and allows the configuration of the UDP port numbers used to identify HPR over IP packets. <b>Note:</b> If APPN is in the load image, this command is not supported since BRS learns from APPN if HPR over IP has been configured and, if it has been configured, learns the UDP port numbers that will be used for HPR over IP packets from the APPN support.
Disable-hpr-over-ip-port-numbers	Disables BRS filtering of APPN-HPR over IP traffic. <b>Note:</b> If APPN is in the load image, this command is not supported since BRS learns from APPN whether or not HPR over IP has been configured.
Interface	Selects an interface on which to configure bandwidth reservation. <b>Note:</b> This command must be entered before using any other configuration commands. See Table 2 and Table 3 on page 22.
List	Lists the interfaces that can support bandwidth reservation and, for each interface, indicates if bandwidth reservation is enabled or disabled.
Exit	Returns you to the previous command level. See "Exiting a Lower Level Environment" on page xxxii.

Table 2. BRS Interface Configuration Commands Available from BRS [i #] Config> prompt for Frame Relay Interfaces

Command	Function
? (Help)	Displays all the commands available for this command level or lists the options for specific commands (if available). See "Getting Help" on page xxxii.
Add-circuit-class	Sets the name of a bandwidth c-class and its percentage of bandwidth.
Assign-circuit	Assigns a specified circuit to the specified bandwidth c-class.
Change-circuit-class	Changes the amount of bandwidth configured for a bandwidth c-class.
Circuit	Accesses the BRS circuit-level prompt (BRS [i x][d1ci y] Config>) prompt where you can use the commands listed in Table 3 on page 22 to configure Bandwidth Reservation on the Frame Relay circuit.
Clear-block	Clears the configuration data associated with the current interface from SRAM. Circuit class configuration data and default circuit definitions for traffic class handling are cleared.
Deassign-circuit	Restores the specified circuit to the default c-class
Default-circuit-class	Assigns the name of a default bandwidth c-class and its percentage of the interface's bandwidth.
Del-circuit-class	Deletes the specified bandwidth c-class.
Disable	Disables bandwidth reservation on the interface .
Enable	Enables bandwidth reservation on the interface.

## Configuring BRS and Priority Queuing

Table 2. BRS Interface Configuration Commands Available from BRS [i #] Config> prompt for Frame Relay Interfaces (continued)

Command	Function
List	Displays the c-classes and assigned circuit definitions from SRAM.
Queue-length	Sets the maximum and minimum values for the number of packets in a priority queue.
Set-circuit-defaults	Accesses the BRS [i x] [circuit defaults] Config> command prompt so that you can use the appropriate commands from Table 3 to create default circuit definitions for traffic class handling.
Show	Displays the currently defined c-classes and assigned circuits from SRAM.
Exit	Returns you to the previous command level. See “Exiting a Lower Level Environment” on page xxxii.

The following table lists BRS circuit commands Available from BRS [i x] Config> for PPP interfaces, BRS [i x] dlci [y] Config> prompt for Frame Relay circuits, and from the BRS [i x] [circuit defaults] Config> prompt.

Table 3. BRS Traffic Class Handling Commands

Command	Function
? (Help)	Displays all the commands available for this command level or lists the options for specific commands (if available). See “Getting Help” on page xxxii.
Add-class	Allocates a designated amount of bandwidth to a user-defined traffic class.
Create-super-class	Defines the t-class called <i>super-class</i> .
Assign	Assigns a protocol or filter to a configured traffic class.
Change-class	Changes the amount of bandwidth configured for a bandwidth t-class.
Clear-block	Clears the traffic class and protocol, filter, and tag assignment configuration data from SRAM for the PPP interface or Frame Relay circuit. <b>Note:</b> This command cannot be used from the BRS [i x] [circuit defaults] Config> prompt.
Deassign	Restores the queuing of the specified packet or filter to the default t-class and priority.
Default-class	Sets the default t-class and priority to a desired value and assigns all unassigned protocols to the new default t-class.
Del-class	Deletes a previously configured bandwidth t-class.
Disable	Disables bandwidth reservation on the PPP interface or Frame Relay circuit. <b>Note:</b> BRS cannot be enabled or disabled from the BRS [i x] [circuit defaults] Config> prompt.
Enable	Enables bandwidth reservation on the PPP interface or Frame Relay circuit. <b>Note:</b> BRS cannot be enabled or disabled from the BRS [i x] [circuit defaults] Config> prompt.
List	Lists the configured t-classes and protocol, filter and tag assignments stored in SRAM.
Queue-length	Sets the maximum and minimum values for the number of packets in a priority queue. <b>Note:</b> This command is not supported at the BRS [i x] [circuit defaults] Config> prompt.
Show	Displays the currently defined t-classes and protocol, filter, and tag assignments stored in RAM. <b>Note:</b> This command is not supported at the BRS [i x] [circuit defaults] Config> prompt.



Table 3. BRS Traffic Class Handling Commands (continued)

Command	Function
Tag	Assigns a BRS tag name (TAG1 - TAG5) to a MAC filter that has been tagged during the configuration of the MAC Filtering feature.
Untag	Removes the relationship between a BRS tag name (TAG1 - TAG5) and a MAC filter that has been tagged during configuration of the MAC filtering feature.
Use-circuit-defaults	Allows the user to delete the circuit-specific definitions and use the circuit-defaults definitions for the traffic-class handling. This command is valid at the BRS [i x] dlci [y] Config> prompt for Frame Relay only. <b>Note:</b> The router must be restarted in order for the defaults to become operational.
Exit	Returns you to the previous command level. See “Exiting a Lower Level Environment” on page xxxii.

Use the appropriate commands to configure bandwidth reservation for the Point-to-Point protocol (PPP) and Frame Relay. For Frame Relay, you need to configure the circuit and the network interface. For PPP, you only need to configure the network interface.

### Notes:

1. When the **clear-block**, **disable**, **enable**, **list**, and **show** commands are issued from within the BRS interface menu, they affect or list the bandwidth reservation information configured for the selected interface. When these commands are issued from within the BRS circuit menu, only the Frame Relay bandwidth reservation information configured for the permanent virtual circuit (PVC) is affected or listed.
2. Before using the bandwidth reservation commands, keep the following in mind:
  - You must use the **interface** command to select an interface before you use any other configuration commands. (BRS configuration enforces this.)
  - The *Class-name* parameter is case-sensitive.
  - To view the current *class-names*, use the **list** or **show** command.
  - After you enable bandwidth reservation on an interface or circuit, you can add/delete/change circuit and traffic classes and assign circuits or protocols dynamically. The only commands that require a router restart before taking effect are the **enable**, **disable**, **use-circuit-defaults**, and **clear-block** commands.
3. You do not need to restart the router for t-class and c-class configuration changes to take effect.

## Activate-IP-precedence-filtering

Use the **activate-ip-precedence-filtering** command to activate BRS IPv4 precedence filtering of APPN and SNA packets that are sent over a secure IP tunnel or that are in secondary TCP or UDP fragments. You also must configure the setting of the IPv4 precedence bits when you configure DLSw, HPR over IP or TN3270. See “Using IP Version 4 Precedence Bit Processing for SNA Traffic in IP Secure Tunnels and Secondary Fragments” on page 9 for more information.

### Syntax:

**activate-ip-precedence-filtering**

## Configuring BRS and Priority Queuing

### Add-circuit-class

**Note:** Used only when configuring Frame Relay.

Use the **add-circuit-class** command at the interface level to allocate a designated amount of bandwidth to be used by the group of circuits assigned to the user-defined bandwidth c-class.

**Syntax:**

**add-circuit-class** *class-name* %

### Add-class

Use the **add-class** command to allocate a designated amount of bandwidth to a user-defined bandwidth t-class.

**Note:** If this command is used for a Frame Relay circuit that is currently using default circuit definitions for traffic class handling, you will be asked whether or not you want to override the default circuit definitions. If you answer “Yes”, the circuit will be changed to use circuit-specific definitions for traffic class handling and the command will be allowed. If you answer “No”, the command is aborted and default circuit definitions will continue to be used for the circuit. If you want to change the default circuit definitions, you should go to the BRS [i x] [circuit defaults]Config> command prompt.

**Syntax:**

**add-class** [*class-name* or *class#*] %

#### Example 1: Adding one class named CIRC17 on a Frame Relay circuit

```
BRS [i 1] [dlci 17] Config>add-class
This circuit is currently using circuit defaults...
Are you sure you want to override the defaults?(Yes or [No]):y
Class name [DEFAULT]? CIRC17
Percent bandwidth to reserve [10]?5
BRS [i 1] [dlci 17] Config>list

BANDWIDTH RESERVATION listing from SRAM
bandwidth reservation is enabled
interface number 1, circuit number 17
maximum queue length 10, minimum queue length 3
total bandwidth allocated 65%
total classes defined (counting one local and one default) 5

class LOCAL has 10% bandwidth allocated
  protocols and filters cannot be assigned to this class.

class DEFAULT has 40% bandwidth allocated
  the following protocols and filters are assigned:
  protocol DNA with default priority is not discard eligible
  protocol VINES with default priority is not discard eligible
  protocol IPX with default priority is not discard eligible
  protocol OSI with default priority is not discard eligible
  protocol VOFR with default priority is not discard eligible
  protocol AP2 with default priority is not discard eligible
  protocol ASRT with default priority is not discard eligible

class DEF1 has 5% bandwidth allocated
  protocol IP with priority NORMAL is not discard eligible.

class DEF2 has 5% bandwidth allocated
  protocol ARP with priority NORMAL is not discard eligible.
```

## Configuring BRS and Priority Queuing

```
class CIRC171 has 5% bandwidth allocated
  no protocols or filters are assigned to this class.
```

```
assigned tags:
```

```
default class is DEFAULT with priority NORMAL
```

### Example 2: Adding one class named class1 on a Frame Relay circuit

```
BRS [i 2] [dlci 128]>add
This circuit is currently using circuit defaults...
Are you sure you want to override the defaults?(Yes or [No]): y
Class name [DEFAULT]?
Class is already allocated.
BRS [i 2] [dlci 128]>add class1
Percent bandwidth to reserve [10]?
BRS [i 2] [dlci 128]>
```

```
BRS [i 2] [dlci 128]>list
```

```
BANDWIDTH RESERVATION listing from SRAM
bandwidth reservation is enabled
interface number 2, circuit number 128
maximum queue length 10, minimum queue length 3
total bandwidth allocated 60%
total classes defined (counting one local and one default) 3
```

```
class LOCAL has 10% bandwidth allocated
  protocols and filters cannot be assigned to this class.
```

```
class DEFAULT has 40% bandwidth allocated
  the following protocols and filters are assigned:
  protocol IP with default priority is not discard eligible
  protocol ARP with default priority is not discard eligible
  protocol DNA with default priority is not discard eligible
  protocol VINES with default priority is not discard eligible
  protocol IPX with default priority is not discard eligible
  protocol OSI with default priority is not discard eligible
  protocol VOFR with default priority is not discard eligible
  protocol AP2 with default priority is not discard eligible
  protocol ASRT with default priority is not discard eligible
```

```
class class1 has 10% bandwidth allocated
  no protocols or filters are assigned to this class.
```

```
assigned tags:
```

```
default class is DEFAULT with priority NORMAL
```

```
BRS [i 2] [dlci 128]>
```

## Assign

Use the **assign** command to assign specified tags, protocol packets, or filters to a given t-class and priority within that class. The four priority types include:

- Urgent
- High
- Normal (the default priority)
- Low.

**Note:** The protocol Voice over Frame Relay (VOFR) is used when voice packets are sent over a Frame Relay interface. If a circuit will carry voice packets only, assign only one t-class on the circuit and specify the protocol as VOFR. Only one t-class is allowed because one t-class does not have priority over another. If there is more than one t-class, a t-class that does not carry voice can get control of the bandwidth and interfere with the transmission of the voice traffic. To ensure that voice traffic will receive immediate transmission, VOFR traffic and VOFR traffic only should be given the priority type *Urgent*.

## Configuring BRS and Priority Queuing

Fragmentation over Frame Relay as described in the **enable fragmentation** command in the chapter “Configuring and Monitoring Frame Relay Interfaces” in *Access Integration Services Software User’s Guide* must be configured over the circuit if it will carry data traffic as well as voice. This is necessary so that large data packets will not use up the bandwidth and prevent the voice packets from getting through quickly enough.

### Syntax:

**assign** [protocol-class or TAG or filter-class] [class-name or class#]

The **assign** command also allows you to set the Discard-eligible (DE) bit for Frame Relay frames.

**Note:** If this command is used for a Frame Relay circuit that is currently using default circuit definitions for traffic class handling, you will be asked whether or not you want to override the default circuit definitions. If you answer “Yes”, the circuit will be changed to use circuit-specific definitions for traffic class handling and the command will be allowed. If you answer “No”, the command is aborted and default circuit definitions will continue to be used for the circuit. If you want to change the default circuit definitions, you should go to the BRS [i x][circuit defaults]Config> command prompt.

### Example 1:

```
assign IPX test
priority <URGENT/HIGH/NORMAL/LOW>: [NORMAL]? low
protocol IPX maps to class test with priority LOW Discard eligible <yes/no> [N]?
```

**Example 2: Assigning a TOS filter to class1; class1 has previously been added to the configuration using the *add class* command.**

```
BRS [i 2] [dldci 128]>assign ?
IP
ARP
DNA
VINES
IPX
OSI
VOFR
AP2
ASRT
TUNNELING-IP
SDLC/BSC-IP
RLOGIN-IP
TELNET-IP
NETBIOS
SNA/APPN-ISR
SNMP-IP
MULTICAST-IP
DLSW-IP
TAG1
TAG2
TAG3
TAG4
TAG5
APPN-HPR
NETWORK-HPR
HIGH-HPR
MEDIUM-HPR
LOW-HPR
XTP-IP
UDP_TCP1
UDP_TCP2
UDP_TCP3
UDP_TCP4
UDP_TCP5
TOS1
TOS2
```

## Configuring BRS and Priority Queuing

```
TOS3
TOS4
TOS5
Protocol or filter name [IP]? TOS1 1
Class name [DEFAULT]? class1 2
Priority [NORMAL]?
Frame Relay Discard Eligible [NO]?
TOS Mask [1-FF] [FF]?
TOS Range (Low) [0-FF] [0]? 1
TOS Range (High) [1]? 3
BRS [i 2] [dlci 128]> list

BANDWIDTH RESERVATION listing from SRAM
bandwidth reservation is enabled
interface number 2, circuit number 128
maximum queue length 10, minimum queue length 3
total bandwidth allocated 60%
total classes defined (counting one local and one default) 3

class LOCAL has 10% bandwidth allocated
  protocols and filters cannot be assigned to this class.

class DEFAULT has 40% bandwidth allocated
  the following protocols and filters are assigned:
    protocol IP with default priority is not discard eligible
    protocol ARP with default priority is not discard eligible
    protocol DNA with default priority is not discard eligible
    protocol VINES with default priority is not discard eligible
    protocol IPX with default priority is not discard eligible
    protocol OSI with default priority is not discard eligible
    protocol VOFR with default priority is not discard eligible
    protocol AP2 with default priority is not discard eligible
    protocol ASRT with default priority is not discard eligible

class class1 has 10% bandwidth allocated
  the following protocols and filters are assigned:
    filter TOS1 with priority NORMAL is not discard eligible
      with TOS range x1 - x3 and TOS mask xFF

assigned tags:

default class is DEFAULT with priority NORMAL

BRS [i 2] [dlci 128]>show

BANDWIDTH RESERVATION currently in RAM
interface number 2, circuit number 128
maximum queue length 10, minimum queue length 3
3 current defined classes:
  class LOCAL has 10% bandwidth allocated
  class DEFAULT has 40% bandwidth allocated
  class class1 has 10% bandwidth allocated

protocol and filter assignments:
```

Protocol/Filter	Class	Priority	Discard Eligible
-----	----	-----	-----
IP	DEFAULT	NORMAL	NO
ARP	DEFAULT	NORMAL	NO
DNA	DEFAULT	NORMAL	NO
VINES	DEFAULT	NORMAL	NO
IPX	DEFAULT	NORMAL	NO
OSI	DEFAULT	NORMAL	NO
VOFR	DEFAULT	NORMAL	NO
AP2	DEFAULT	NORMAL	NO
ASRT	DEFAULT	NORMAL	NO
TOS1	class1	NORMAL	NO
with TOS range x1 - x3			
and TOS mask xFF			

```
BRS [i 2] [dlci 128]>
```

**1** Using the TOS filter requires you to enter three parameters: TOS mask, TOS range-low, and TOS range-high. Refer to the command “Add” in the chapter

## Configuring BRS and Priority Queuing

“Configuring and Monitoring IP” in the *Protocol Configuration and Monitoring Reference Volume 1* for a description of these parameters.

## Assign-circuit

**Note:** Used only when configuring Frame Relay.

Use the **assign-circuit** command at the interface level to assign the specified circuit to the specified bandwidth c-class. Use the DLCI when assigning a PVC to a circuit class and the circuit name when assigning an SVC to a circuit class.

**Note:** You must use the **circuit** command to enable BRS on the virtual circuit and restart or reload the router before you can use this command to assign the circuit to a circuit class.

**Syntax:**

**assign-circuit**                      # class name

## Change-circuit-class

**Note:** Used only when configuring Frame Relay.

Use the **change-circuit-class** command at the interface level to change the percentage of the bandwidth to be used by the group of circuits assigned to the specified c-class.

**Syntax:**

**change-circuit-class**              class-name %

## Change-class

Use the **change-class** command to change the amount of bandwidth configured for a bandwidth t-class.

**Note:** If this command is used for a Frame Relay circuit that is currently using default circuit definitions for traffic class handling, you will be asked whether or not you want to override the default circuit definitions. If you answer “Yes”, the circuit will be changed to use circuit-specific definitions for traffic class handling and the command will be allowed. If you answer “No”, the command is aborted and default circuit definitions will continue to be used for the circuit. If you want to change the default circuit definitions, you should go to the BRS [i x][circuit defaults]Config> command prompt.

**Syntax:**

**change-class**                      [class-name or class#] %

## Circuit

**Note:** Used only when configuring Frame Relay.

Use the **circuit** command to configure a Frame Relay permanent virtual circuit (PVC) or switched virtual circuit (SVC). This command can only be issued from the BRS interface configuration prompt (BRS [i #] Config>).

### Syntax:

#### circuit

Before you can use the **add-class**, **assign**, **default-class**, **del-class**, **deassign**, or **change-class** commands, you must enable BRS on the circuit and restart or reload the router.

### PVC example:

```
BRS [i 1] Config> circuit
Circuit (PVC number or SVC name) to reserve bandwidth: [16]

BRS [i 1 ] [d]ci 16] Config> enable
```

### SVC example:

```
BRS [i 1] Config> circuit
Circuit (PVC number or SVC name) to reserve bandwidth: [16] svc01

BRS [i 1 ] [svc svc01] Config> enable
```

After the **enable** command is issued for the Frame Relay circuit and the router is restarted or reloaded, the following configuration commands are available for the circuit:

add-class	deassign	enable	tag
assign	default-class	exit	untag
change-class	del-class	list	clear-block
disable	show	use-circuit-defaults	

## Clear-block

Use the **clear-block** command to clear the current bandwidth reservation configuration data from SRAM.

### Syntax:

#### clear-block

- If you enter this command from the interface prompt for PPP, all BRS configuration data is cleared for the interface.
- If you enter this command from the interface prompt for Frame Relay, BRS is no longer enabled on the interface or on any circuits of the interface, and all circuit-class configuration data and default circuit definitions for traffic class handling are cleared. However, the traffic-class configuration data for each individual circuit is not cleared and is available if you re-enable BRS on the interface.
- To clear a circuit's traffic-class configuration data, you first enter the **circuit** command from the interface-level prompt and then the **clear-block** command from the circuit-level prompt. After you have cleared the traffic-class configuration data for each circuit, enter the **clear-block** command from the interface-level prompt to clear the circuit-class configuration data. The changes do not take effect until the router is restarted or reloaded.

### Example:

#### **clear-block**

```
You are about to clear BRS configuration information for this interface
Are you sure you want to do this (Yes or No): y
BRS [i 1] Config>
```

## Configuring BRS and Priority Queuing

### Create-super-class

Use the **create-super-class** command to configure a t-class called *super-class* on the PPP interface or Frame Relay circuit. Only one super-class can be configured for each PPP interface or Frame Relay circuit. No bandwidth percentage is associated with the super-class. Any protocol or filter data that is assigned to a super-class will be transmitted prior to protocol or filter data assigned to any other t-classes on the PPP interface or the Frame Relay circuit. A super-class for the Voice over Frame Relay (VOFR) protocol should be configured for a circuit that transports both voice and data packets. In this environment, configuring the super-class to carry voice helps to insure that voice packets get priority.

**Syntax:**

**create-super-class**

### Deactivate-IP-precedence-filtering

Use the **deactivate-ip-precedence-filtering** command to deactivate IPv4 precedence filtering processing.

**Syntax:**

**deactivate-ip-precedence-filtering**

### Deassign

Use the **deassign** command to restore the queuing of the specified protocol packet or filter to the default t-class and priority.

**Note:** If this command is used for a Frame Relay circuit that is currently using default circuit definitions for traffic class handling, you will be asked whether or not you want to override the default circuit definitions. If you answer “Yes”, the circuit will be changed to use circuit-specific definitions for traffic class handling and the command will be allowed. If you answer “No”, the command is aborted and default circuit definitions will continue to be used for the circuit. If you want to change the default circuit definitions, you should go to the BRS [i x][circuit defaults]Config> command prompt.

**Syntax:**

**deassign** [prot-class or filter-class]

### Deassign-circuit

**Note:** Used only when configuring Frame Relay.

Use the **deassign-circuit** command at the interface level to restore the queuing of the specified circuit to the default c-class.

**Syntax:**

**deassign-c** #

### Default-circuit-class

**Note:** Used only when configuring Frame Relay.



## Configuring BRS and Priority Queuing

Use the **default-circuit-class** command at the interface level to set the user-defined name of the default bandwidth c-class and the percentage of the bandwidth allocated to that class of circuits, including orphans, that are not assigned to a bandwidth c-class.

### Syntax:

**default-circuit-class** *class-name* %

## Del-circuit-class

**Note:** Used only when configuring Frame Relay.

Use the **del-circuit-class** command at the interface level to delete the specified bandwidth c-class.

### Syntax:

**del-circuit-class** *class-name*

## Default-class

Use the **default-class** command to set the default t-class and priority to a desired value. If no value has been previously assigned, system default values are used. Otherwise, the last previously assigned value is used.

**Note:** If this command is used for a Frame Relay circuit that is currently using default circuit definitions for traffic class handling, you will be asked whether or not you want to override the default circuit definitions. If you answer “Yes”, the circuit will be changed to use circuit-specific definitions for traffic class handling and the command will be allowed. If you answer “No”, the command is aborted and default circuit definitions will continue to be used for the circuit. If you want to change the default circuit definitions, you should go to the BRS [i x][circuit defaults]Config> command prompt.

### Syntax:

**default-cl** [*class-name* or *class#*] *priority*

## Del-class

Use the **del-class** command to delete a previously configured bandwidth t-class from the specified interface or circuit.

**Note:** If this command is used for a Frame Relay circuit that is currently using default circuit definitions for traffic class handling, you will be asked whether or not you want to override the default circuit definitions. If you answer “Yes”, the circuit will be changed to use circuit-specific definitions for traffic class handling and the command will be allowed. If you answer “No”, the command is aborted and default circuit definitions will continue to be used for the circuit. If you want to change the default circuit definitions, you should go to the BRS [i x][circuit defaults]Config> command prompt.

### Syntax:

**del-class** [*class-name* or *class#*]

## Configuring BRS and Priority Queuing

### Disable

Use the **disable** command to disable bandwidth reservation on the interface (if entered from the interface prompt) or on the circuit (if entered from the circuit prompt). The changes do not take effect until the router is restarted or reloaded.

To verify that bandwidth reservation is disabled, enter the **list** command.

#### Syntax:

**disable**

### Disable-hpr-over-ip-port-numbers

Use the **disable-hpr-over-ip-port-numbers** command to disable BRS filtering of HPR over IP traffic.

#### Syntax:

**disable-hpr-over-ip-port-numbers**

To verify that BRS filtering of HPR over IP traffic is disabled, enter the **list** command.

**Note:** If APPN is included in the load image, you configure whether or not HPR over IP traffic will be used at the APPN Config> command prompt.

### Enable

Use the **enable** command to enable bandwidth reservation on the interface (if entered from the interface prompt) or the circuit (if entered from the circuit prompt). The changes do not take effect until the router is restarted or reloaded.

#### Syntax:

**enable**

#### Notes:

1. When configuring BRS on a PPP interface, issue the **enable** command at the interface prompt, and then restart or reload the router before configuring any traffic classes and assigning protocols and filters to traffic classes.
2. When BRS is initially enabled on a Frame Relay circuit, the circuit is initialized to use default circuit definitions for traffic class handling. Issue the **enable** command at the interface prompt and at the circuit prompt of each circuit for which you want to define traffic classes. Then restart or reload the router before configuring circuit classes for the interface and traffic classes for each circuit. For example:

```
t 6
Gateway user configuration
Config>f brs
Bandwidth Reservation User Configuration
BRS Config>interface 1
BRS [i 1] Config>enable
Please restart router for this command to take effect
BRS [i 1] Config>list

BANDWIDTH RESERVATION listing from SRAM
bandwidth reservation is enabled
interface number 1
maximum queue length 10, minimum queue length 3
total bandwidth allocated 10%
total circuit classes defined (counting one default) 1
```

```
class DEFAULT has 10% bandwidth allocated
  no circuits are assigned to this class.

default class is DEFAULT

BRS [i 1] Config>circ 16
BRS [i 1] [dldci 16] Config>enable
Defaults are in effect for this circuit.
Please restart router for this command to take effect.
BRS [i 1] [dldci 16] Config>ex
Please restart router for this command to take effect.
BRS [i 1] [dldci 16] Config>
*restore
Are you sure you want to restart the gateway? (Yes or [No]): y
```

### Enable-hpr-over-ip-port-numbers

Use the **enable-hpr-over-ip-port-numbers** command to enable BRS filtering of APPN-HPR over IP traffic and to configure UDP port numbers used to identify HPR over IP packets.

**Note:** If APPN is included in the load image, you enable HPR over IP and specify the UDP port numbers used for HPR over IP traffic at the APPN Config> command prompt.

#### Syntax:

**enable-hpr-over-ip-port-numbers**

#### Example:

```
BRS Config> enable-hpr-over-ip-port-numbers
XID exchange port number [12000]?
HPR net trans prio port number [12001]?
HPR high trans prio port number [12002]?
HPR medium trans prio port number [12003]?
HPR low trans prio port number [12004]?
```

#### XID exchange port number

This parameter specifies the UDP port number to be used for XID exchange. This port number must be the same as the one defined on other devices in the network.

**Valid Values:** 1024 - 65535

**Default Value:** 12000

#### Network priority port number

This parameter specifies the UDP port number to be used for network priority traffic. This port number must be the same as the one defined on other devices in the network.

**Valid Values:** 1024 - 65535

**Default Value:**12001

#### High exchange port number

This parameter specifies the UDP port number to be used for high priority traffic. This port number must be the same as the one defined on other devices in the network.

**Valid Values:** 1024 - 65535

**Default Value:**12002

## Configuring BRS and Priority Queuing

### Medium exchange port number

This parameter specifies the UDP port number to be used for medium priority traffic. This port number must be the same as the one defined on other devices in the network.

**Valid Values:** 1024 - 65535

**Default Value:**12003

### Low exchange port number

This parameter specifies the UDP port number to be used for low priority traffic. This port number must be the same as the one defined on other devices in the network.

**Valid Values:** 1024 - 65535

**Default Value:**12004

## Interface

Use the **interface** command to select the serial interface to which bandwidth reservation configuration commands will be applied. *Bandwidth reservation is supported on routers running PPP (Point-to-Point Protocol) and Frame Relay interfaces.*

**Note:** Bandwidth Reservation is not supported over Frame Relay subinterfaces. See Using Frame Relay Interfaces in *Access Integration Services Software User's Guide* for more information.

### Syntax:

**interface** *interface#*

### Notes:

1. To enter bandwidth reservation commands for a new interface, this command must be entered **before** using any other bandwidth reservation configuration commands. If you have exited the bandwidth reservation prompt and wish to return to make bandwidth reservation changes to a previously configured interface, this command must again be entered first.
2. If WAN Restoral is used and BRS is configured on a primary interface, BRS should also be configured on the secondary interface. Typically when WAN Restoral is used, the secondary interface takes on the identity of the primary interface. This is not true for BRS; therefore, BRS needs to be configured on both the primary and secondary interfaces.

To enable Bandwidth Reservation on a particular interface, at the BRS Config> prompt, enter the number of the interface that supports the particular protocol or feature. You can then use the BRS Talk 6 **enable** command as described in this chapter. After enabling the interface number, you must restart or reload the 2212 for the command to take effect before you can make any other configuration changes to the interface.

**Note:** If you are configuring BRS on a Frame Relay interface, you can use the **circuit** command to select circuits and enable bandwidth reservation on those circuits before you restart or reload the router.

## List

Use the **list** command to display currently defined bandwidth classes and their guaranteed percentage rates.

## Configuring BRS and Priority Queuing

The **list** command and **show** command are similar. The **list** command displays the current SRAM definitions and the **show** command displays the current RAM definitions.

### Syntax:

```
list interface#
```

Depending on the prompt at which you issue the **list** command, various outputs are displayed. You can issue the **list** command from the following prompts:

- BRS [i 1] [dlci 16] Config>
- BRS [i 1] Config>
- BRS Config>
- BRS [i 1] [circuit defaults] Config>

**Note:** When you use this command from a Frame Relay circuit prompt (BRS [i x] [dlci y] Config>) it indicates if the circuit is using default circuit definitions or circuit-specific definitions for traffic class handling. If the circuit is using default circuit definitions, the traffic class, protocol, filter, and tag assignments currently defined for default circuit definitions are displayed. However, if you want to alter the default circuit definitions, you need to get to the BRS [i x] [circuit defaults] Config> prompt to make changes.

At the BRS interface level prompt (BRS [i 0]) for PPP interfaces and at the BRS circuit level prompt (BRS [i 0] [dlci 16] Config>) for Frame Relay interfaces, the **list** command lists the traffic classes, their configured bandwidth percentages, and the assigned protocols and filters.

At the BRS interface level prompt for Frame Relay, the **list** command lists the circuit classes, their configured bandwidth percentages, and the assigned circuits.

### Example 1

```
BRS Config>list
Bandwidth Reservation is available for 2 interfaces.

Interface  Type      State
-----  ----  -----
          1  FR      Enabled
          2  PPP     Enabled

The use of HPR over IP port numbers is disabled

BRS Config>interface 1
BRS [i 1] Config>list

BANDWIDTH RESERVATION listing from SRAM
bandwidth reservation is enabled
interface number 1
maximum queue length 10, minimum queue length 3
total bandwidth allocated 10%
total circuit classes defined (counting one default) 1

class DEFAULT has 10% bandwidth allocated
the following circuits are assigned:
  17
  16 using defaults.
  18 using defaults.

default class is DEFAULT

BRS [i 2] Config>exit
BRS Config>interface 2
BRS [i 2] Config>list

BANDWIDTH RESERVATION listing from SRAM
bandwidth reservation is enabled
```

## Configuring BRS and Priority Queuing

```
interface number 2
maximum queue length 10, minimum queue length 3
total bandwidth allocated 50%
total classes defined (counting one local and one default) 2

class LOCAL has 10% bandwidth allocated
  protocols and filters cannot be assigned to this class.

class DEFAULT has 40% bandwidth allocated
  the following protocols and filters are assigned:
  protocol IP with default priority
  protocol ARP with default priority
  protocol DNA with default priority
  protocol VINES with default priority
  protocol IPX with default priority
  protocol OSI with default priority
  protocol VOFR with default priority
  protocol AP2 with default priority
  protocol ASRT with default priority

assigned tags:

default class is DEFAULT with priority NORMAL

BRS [i 2] Config>
```

### Example 2

```
BRS [i 1] [d1ci 17] Config>list

BANDWIDTH RESERVATION listing from SRAM
bandwidth reservation is enabled
maximum queue length 10, minimum queue length 3
total bandwidth allocated 60%
total classes defined (counting one local and one default) 3

class LOCAL has 10% bandwidth allocated
  protocols and filters cannot be assigned to this class.

class DEFAULT has 40% bandwidth allocated
  the following protocols and filters are assigned:
  protocol ASRT with priority NORMAL is not discard eligible
  filter NETBIOS with priority NORMAL is not discard eligible

class CLASS1 has 10% bandwidth allocated
  the following protocols and filters are assigned:
  protocol IP with priority NORMAL is not discard eligible
  protocol ARP with priority NORMAL is not discard eligible
  protocol DNA with priority NORMAL is not discard eligible
  protocol VINES with priority NORMAL is not discard eligible
  protocol IPX with priority NORMAL is discard eligible
  protocol OSI with priority NORMAL is not discard eligible
  protocol VOFR with priority NORMAL is not discard eligible
  protocol AP2 with priority NORMAL is not discard eligible
```

### Example 3

```
BRS [i 1] [circuit defaults] Config>list

BANDWIDTH RESERVATION listing from SRAM
bandwidth reservation is enabled
interface number 1, default circuit
maximum queue length 10, minimum queue length 3
total bandwidth allocated 70%
total classes defined (counting one local and one default) 4

class LOCAL has 10% bandwidth allocated
  protocols and filters cannot be assigned to this class.

class DEFAULT has 40% bandwidth allocated
  the following protocols and filters are assigned:
  protocol DNA with default priority is not discard eligible
  protocol VINES with default priority is not discard eligible
  protocol IPX with default priority is not discard eligible
  protocol OSI with default priority is not discard eligible
  protocol VOFR with default priority is not discard eligible
  protocol AP2 with default priority is not discard eligible
  protocol ASRT with default priority is not discard eligible
```

## Configuring BRS and Priority Queuing

```
class DEF1 has 10% bandwidth allocated
  protocol IP with priority NORMAL is not discard eligible.
```

```
class DEF2 has 10% bandwidth allocated
  protocol ARP with priority NORMAL is not discard eligible.
```

assigned tags:

```
default class is DEFAULT with priority NORMAL
```

```
BRS [i 1] [circuit defaults] Config>
```

### Example 4

```
BRS Config>list
Bandwidth Reservation is available for 2 interfaces.
```

Interface	Type	State
1	FR	Enabled
2	PPP	Enabled

The use of HPR over IP port numbers is enabled.

Transmission Type	Port Number
XID exchange	12000
HPR network	12001
HPR high	12002
HPR medium	12003
HPR low	12004

## Queue-length

Use the **queue-length** command to set the number of packets that can be queued in each BRS priority queue. Each BRS class has a priority value assigned to its protocols, filters, and tags, and each priority queue can store the number of packets that you specify with this command.

### Syntax:

**queue-length** *maximum-length minimum-length*

This command sets the maximum number of buffers that can be queued in each BRS priority queue as well as the maximum number that can be queued in each BRS priority queue when there is a shortage of router input buffers.

If you issue **queue-length** for a PPP interface, the command sets the queue-length values for each priority queue of each BRS t-class that is defined for the interface.

If you issue **queue-length** for a Frame Relay interface (at the prompt: BRS [i 0] Config>), the command sets the default queue-length values for each priority queue of each BRS t-class that is defined for each permanent virtual circuit of the interface.

If you issue **queue-length** for a Frame-Relay PVC (at a prompt like this: BRS [i 0] [d1ci 16] Config>) the command sets the queue length values for each priority queue of each BRS t-class that is defined for the PVC. These values override the default queue length values set for the Frame Relay interface.

**Attention:** Do not use this command unless it is essential to do so. The default values for queue length are the recommended values for most users. If you set the values for queue length too high, you may seriously degrade the performance of your router.

## Configuring BRS and Priority Queuing

### Set-circuit-defaults

Use the **set-circuit-defaults** command to access the commands used to define default circuit definitions for traffic class handling. These default circuit definitions can then be used by any Frame Relay circuits on the interface that can use the same traffic classes and protocol, filter, and tag assignments.

#### Syntax:

**set-circuit-defaults**

### Show

Use the **show** command to display currently defined bandwidth classes stored in RAM.

#### Syntax:

**show** *interface#*

Depending on the prompt at which you issue the **show** command, various outputs are displayed. You can issue the **show** command from the following prompts:

- BRS [i x] Config> - interface level prompt for interface number x.
- BRS [i x] [dlci y] Config> - circuit level prompt for circuit y on Frame Relay interface number x. The following example shows the output of the show command from the circuit level prompt.

```
BRS [i 1] [dlci 17] Config>show
```

Protocol/Filter	Class	Priority	Discard Eligible
-----	----	-----	-----
IP	CLASS1	NORMAL	NO
ARP	CLASS1	NORMAL	NO
DNA	CLASS1	NORMAL	NO
VINES	CLASS1	NORMAL	NO
IPX	CLASS1	NORMAL	YES
OSI	CLASS1	NORMAL	NO
VOFR	CLASS1	NORMAL	NO
AP2	CLASS1	NORMAL	NO
ASRT	DEFAULT	NORMAL	NO
NETBIOS	DEFAULT	NORMAL	NO

At the interface prompt for PPP and the circuit prompt for Frame Relay, traffic class information is displayed. At the interface prompt for Frame Relay, circuit class information is displayed.

#### Notes:

1. When you use this command from a Frame Relay circuit prompt (BRS [i x] [dlci y] Config>) it indicates if the circuit is using default circuit definitions or circuit-specific definitions for traffic class handling. If the circuit is using default circuit definitions, the traffic class, protocol, filter, and tag assignments currently defined for default circuit definitions are displayed. However, if you want to alter the default circuit definitions, you need to get to the BRS [i x] [circuit defaults] Config> prompt to make changes.
2. This command cannot be used from the BRS [i x] [circuit defaults] Config> prompt.

### Tag

Use the **tag** command to assign a MAC filter item that has been tagged during the configuration of the MAC filtering feature to the next available BRS tag name. The BRS tag names are TAG1, TAG2, TAG3, TAG4, and TAG5. You use the BRS tag name on the assign command to assign the tag to a BRS traffic class.



### Syntax:

tag *mac\_filter\_tag#*

Use the **list** command to list which MAC filter tags have been assigned to a BRS tag name and which BRS tag names have been assigned to a bandwidth traffic class.

**Note:** If this command is used for a Frame Relay circuit that is currently using default circuit definitions for traffic class handling, you will be asked whether or not you want to override the default circuit definitions. If you answer “Yes”, the circuit will be changed to use circuit-specific definitions for traffic class handling and the command will be allowed. If you answer “No,” the command is aborted and default circuit definitions will continue to be used for the circuit. If you want to change the default circuit definitions, you should go to the BRS [i x][circuit defaults]Config> command prompt.

## Untag

Use the **untag** command to remove the MAC filter tag number and BRS tag name relationship. A tag can be removed only if its corresponding BRS tag name is not assigned to a bandwidth traffic class.

### Syntax:

untag *mac\_filter\_tag#*

Use the **list** command to show which MAC filter tags are assigned to a BRS tag name and which BRS tag names are assigned to a traffic class.

**Note:** If this command is used for a Frame Relay circuit that is currently using default circuit definitions for traffic class handling, you will be asked whether or not you want to override the default circuit definitions. If you answer “Yes”, the circuit will be changed to use circuit-specific definitions for traffic class handling and the command will be allowed. If you answer “No”, the command is aborted and default circuit definitions will continue to be used for the circuit. If you want to change the default circuit definitions, you should go to the BRS [i x][circuit defaults]Config> command prompt.

## Use-circuit-defaults

Use the **use-circuit-defaults** command at the circuit level to delete the circuit-specific definitions and use the circuit default definitions for traffic-class handling. You will be prompted to confirm that you want to use the circuit defaults.

### Syntax:

use-circuit-defaults

### Notes:

1. This command is used only when configuring Frame Relay
2. The router must be restarted or reloaded for the defaults to become operational.

### Example:

```
BRS [i 1] [dldi 17] Config>use-circuit-defaults
This circuit is currently NOT using circuit defaults...
Are you sure you want to delete current definitions and use defaults ? (Yes or
[No]): y
Defaults are in effect for this circuit.
Please restart router for this command to take effect.
```

## Configuring BRS and Priority Queuing

```
BRS [i 1] [d1ci 17] Config>
*restart
Are you sure you want to restart the gateway? (Yes or [No]): y
```

---

## Accessing the Bandwidth Reservation Monitoring Prompt

To access bandwidth reservation monitoring commands and to monitor bandwidth reservation on your router, do the following:

1. At the OPCON prompt (\*), type **talk 5**.
2. At the GWCON prompt (+), type **feature brs**.
3. At the BRS> prompt, type **interface #**, where # is the number of the interface that you want to monitor. This takes you to the BRS interface-level prompt, BRS [i x]>, where x is the interface number.
4. For Frame Relay only, type **circuit #** at the interface prompt to specify the circuit on this interface that you want to monitor.  
This takes you to the circuit-level prompt BRS [i x] [d1ci y]>, where x is the interface number and y is the circuit number.
5. At the prompt, type the appropriate monitoring command. (Refer to “Bandwidth Reservation Monitoring Commands”.)

The **talk 5 (t 5)** command lets you access the monitoring process.

The **feature brs** command lets you access the BRS monitoring process. You can enter this command by using either the feature name (brs) or number (1).

The **interface #** command selects the particular interface that you want to monitor for bandwidth reservation.

The **circuit #** command selects the DLCI of a Frame Relay permanent virtual circuit (PVC).

To return to the GWCON prompt at any time, type the **exit** command at the BRS> prompt.

Once you access the bandwidth reservation monitoring prompt (BRS>), you can enter any of the specific monitoring commands described in Table 4.

---

## Bandwidth Reservation Monitoring Commands

This section summarizes and explains the Bandwidth Reservation monitoring commands. 4 shows the Bandwidth Reservation monitoring commands. The commands that can be used differ depending on the BRS monitoring prompt (BRS>, BRS [i x]>, or BRS [i x] [d1ci y]>).

Table 4. Bandwidth Reservation Monitoring Command Summary

Command	Used Only With FR	Function
? (Help)		Displays all the commands available for this command level or lists the options for specific commands (if available). See “Getting Help” on page xxxii
Circuit	yes	Selects the DLCI of a Frame Relay permanent virtual circuit (PVC). To monitor Frame Relay bandwidth reservation traffic, you must be at the circuit prompt level.
Clear		Clears the current t-class counters and stores them as <b>last</b> t-class counters. Counters are listed by class.

Table 4. Bandwidth Reservation Monitoring Command Summary (continued)

Command	Used Only With FR	Function
Clear-circuit-class	yes	Clears the current c-class counters and stores them as <b>last</b> c-class counters. Counters are listed by class.
Counters		Displays the current t-class counters.
Counters-circuit-class	yes	Displays the current c-class counters.
Interface		Selects the interface to monitor. <b>Note:</b> This command must be entered before using any other bandwidth reservation monitoring commands.
Last		Displays the last saved t-class counters.
Last-circuit-class	yes	Displays the last saved c-class counters.
Exit		Returns you to the previous command level. See "Exiting a Lower Level Environment" on page xxxii

## Circuit

**Note:** Used only when monitoring Frame Relay.

Use the **circuit** command to select the DLCI of a Frame Relay PVC for monitoring. This command can be issued only from the BRS interface monitoring prompt (BRS [i #]>).

### Syntax:

**circuit** *permanent-virtual-circuit-#*

After the Frame Relay circuit has been selected, the following commands can be used at the circuit prompt:

```
CLEAR
COUNTERS
LAST
EXIT
```

## Clear

Use the **clear** command to save the current bandwidth reservation t-class counters so that they can be retrieved using the **last** command and clear the values. The counters are kept on a bandwidth traffic class basis.

### Syntax:

**clear**

## Clear-Circuit-Class

**Note:** Used only when monitoring Frame Relay.

Use the **clear-circuit-class** command to save the current bandwidth reservation c-class counters so that they can be retrieved using the **last-circuit-class** command and clear the values. The counters are kept on a circuit class basis.

### Syntax:

**clear-circuit-class**

## Monitoring BRS Counters

Use the **counters** command to display statistics describing bandwidth reservation traffic for the traffic classes configured for a PPP interface or Frame Relay circuit.

### Syntax:

#### counters

#### Example:

##### **counters**

```
Bandwidth Reservation Counters
interface number 1
Class      Pkt Xmit      Bytes Xmit      Bytes Ovf1      Pkt Ovf1      Q_len
LOCAL
  LOW      0              0              0              0              0
  NORMAL   10             914            0              0              0
  HIGH     0              0              0              0              0
  URGENT   0              0              0              0              0
DEFAULT
  LOW      0              0              0              0              0
  NORMAL   20             5020           0              0              0
  HIGH     0              0              0              0              0
  URGENT   35             535            0              0              0
CLASS_1
  LOW      0              0              0              0              0
  NORMAL   5              910            0              0              0
  HIGH     0              0              0              0              0
  URGENT   0              0              0              0              0
CLASS_2
  LOW      70             4123           0              0              0
  NORMAL   10             617            0              0              0
  NORMAL   55             3117           0              0              0
  HIGH     0              0              0              0              0
  URGENT   5              389            0              0              0
TOTAL      140            11502          0              0
```

#### **Bytes Ovf1**

Lists the number of bytes for packets that could not be transmitted because either the maximum queue-length was reached for a priority queue or the packet could not be queued because the priority queue was at the minimum queue length threshold and the packet came from an interface that was running low on receive buffers.

#### **Pkt Ovf1**

Lists the number of packets that could not be transmitted because either the maximum queue-length was reached for a priority queue or the packet could not be queued because the priority queue was at the minimum queue length threshold and the packet came from an interface that was running low on receive buffers.

**Q\_len** The current number of packets waiting for transmit on each of the priority queues within each traffic class.

## Counters-circuit-class

**Note:** Used only when monitoring Frame Relay.

Use the **counters-circuit-class** command to display statistics for the traffic classes configured for a Frame Relay circuit.

### Syntax:

#### counters-circuit-class

#### Example:

```
counters-circuit-class
```

Bandwidth Reservation Circuit Class Counters  
Interface 1

Class	Pkt Xmit	Bytes Xmit	Bytes Ovf1
DEFAULT	25	3402	26
CIRCLASS1	1	56	0
CIRCLASS2	0	0	0
TOTAL	26	3458	26

## Interface

Use the **interface** command to select the serial interface to which bandwidth reservation monitoring commands will be applied. *Bandwidth reservation is supported on routers running the PPP (Point-to-Point Protocol) and Frame Relay interfaces.*

### Syntax:

```
interface                interface#
```

**Note:** To enter bandwidth reservation commands for a new interface, this command must be entered before using any other bandwidth reservation monitoring commands. If you have exited the bandwidth reservation monitoring prompt (BRS>) and want to return to monitor bandwidth reservation, you must again enter this command first.

To monitor Bandwidth Reservation on a particular interface, at the BRS> monitoring prompt, type the number of the interface. You can then use bandwidth reservation monitoring commands as described in this chapter.

## Last

Use the **last** command to display the last saved t-class statistics. The t-class statistics are displayed in the same format as they are for the **counters** command.

### Syntax:

```
last
```

## Last-circuit-class

**Note:** Used only when monitoring Frame Relay.

Use the **last-circuit-class** command to display the last saved circuit class statistics. The c-class statistics are displayed in the same format as they are for the **counters-circuit-class** command.

### Syntax:

```
last-circuit-class
```

---

## Bandwidth Reservation Dynamic Reconfiguration Support

This section describes dynamic reconfiguration (DR) as it affects Talk 6 and Talk 5 commands.

### CONFIG (Talk 6) Delete Interface

Bandwidth Reservation supports the CONFIG (Talk 6) **delete interface** command with no restrictions.

## Monitoring BRS

### GWCON (Talk 5) Activate Interface

Bandwidth Reservation supports the GWCON (Talk 5) **activate interface** command with no restrictions.

All Bandwidth Reservation interface-specific commands are supported by the GWCON (Talk 5) **activate interface** command.

### GWCON (Talk 5) Reset Interface

Bandwidth Reservation supports the GWCON (Talk 5) **reset interface** command with no restrictions.

All Bandwidth Reservation interface-specific commands are supported by the GWCON (Talk 5) **reset interface** command.

### CONFIG (Talk 6) Immediate Change Commands

Bandwidth Reservation supports the following CONFIG commands that immediately change the operational state of the device. These changes are saved and are preserved if the device is reloaded, restarted, or you execute a dynamically reconfigurable command.

Commands
GWCON, feature brs, activate-ip-precedence-filtering
GWCON, feature brs, deactivate-ip-precedence-filtering
GWCON, feature brs, enable-hpr-over-ip-port-numbers
GWCON, feature brs, disable-hpr-over-ip-port-numbers
GWCON, feature brs, interface, add-circuit-class
GWCON, feature brs, interface, assign-circuit
GWCON, feature brs, interface, change-circuit-class
GWCON, feature brs, interface, deassign-circuit
GWCON, feature brs, interface, default-circuit-class
GWCON, feature brs, interface, del-circuit-class
GWCON, feature brs, interface, disable
GWCON, feature brs, interface, enable
GWCON, feature brs, interface, queue-length
GWCON, feature brs, interface, add-class <b>Note:</b> This command can also be used at the circuit level for Frame Relay interfaces.
GWCON, feature brs, interface, assign <b>Note:</b> This command can also be used at the circuit level for Frame Relay interfaces.
GWCON, feature brs, interface, change-class <b>Note:</b> This command can also be used at the circuit level for Frame Relay interfaces.
GWCON, feature brs, interface, create-super-class <b>Note:</b> This command can also be used at the circuit level for Frame Relay interfaces.
GWCON, feature brs, interface, deassign <b>Note:</b> This command can also be used at the circuit level for Frame Relay interfaces.
GWCON, feature brs, interface, default-class <b>Note:</b> This command can also be used at the circuit level for Frame Relay interfaces.
GWCON, feature brs, interface, del-class <b>Note:</b> This command can also be used at the circuit level for Frame Relay interfaces.

GWCON, feature brs, interface, disable <b>Note:</b> This command can also be used at the circuit level for Frame Relay interfaces.
GWCON, feature brs, interface, enable <b>Note:</b> This command can also be used at the circuit level for Frame Relay interfaces.
GWCON, feature brs, interface, tag <b>Note:</b> This command can also be used at the circuit level for Frame Relay interfaces.
GWCON, feature brs, interface, untag <b>Note:</b> This command can also be used at the circuit level for Frame Relay interfaces.

## Monitoring BRS



---

## Chapter 3. Using MAC Filtering

This chapter describes how to use medium access control (MAC) for specifying packet filters to be applied to packets during processing. It includes the following sections:

- “MAC Filtering and DLSw Traffic”
- “MAC Filtering Parameters”

Filters are a set of rules applied to a packet to determine how the packet should be handled during bridging. MAC filtering affects only bridged traffic.

**Note:** MAC Filtering is allowed on tunnel traffic.

During the filtering process, packets are processed, filtered, or tagged during bridging. The actions are:

- **Processed** – Packets are permitted to pass unaffected through the bridge.
- **Filtered** – Packets are not permitted to pass through the bridge.
- **Tagged** – Packets are allowed to pass through the bridge, but are marked with a number in the range 1 through 64 based on a configurable parameter.

A MAC filter consists of the following objects:

1. Filter-item – which is a single rule that is applied to the address field or an arbitrary window of data within a packet. The result of applying the rule is either a true (successful match) or false (no match) condition.
2. Filter-list – which contains a list of one or more filter-items.
3. Filter – which contains a set of filter-lists.

---

### MAC Filtering and DLSw Traffic

You can filter incoming LLC traffic for the DLSw network by implementing MAC Filtering.

To set up a filter for LLC, use the *Bridge Net* number as the interface number for the filter. Determine the Bridge Net number by adding two to the number of interfaces configured for your router. Enter the **list devices** command at the Config> prompt, or enter **configuration** at the + prompt to see a list of interfaces.

In the following example, the Bridge Net number is 7.

Ifc 0 Token Ring	Slot: 1	Port: 1
Ifc 1 Token Ring	Slot: 1	Port: 2
Ifc 2 Token Ring	Slot: 2	Port: 1
Ifc 3 Token Ring	Slot: 2	Port: 2
Ifc 4 Ethernet	Slot: 4	Port: 1
Ifc 5 Ethernet	Slot: 4	Port: 2

When you set up a filter for the Bridge Net, for example, the router does not drop frames that match exclusive filters. Instead, it forwards those frames to the bridge.

---

### MAC Filtering Parameters

You can specify some or all of the following parameters to create a filter:

- Source MAC address or destination MAC address
- Data to be matched within the packet
- Mask to be applied to the packet's fields to be filtered
- Interface number
- Input/Output designation

## Using MAC Filtering

- Include/Exclude/Tag designation
- Tag value (if the tag designation is given)

## Filter-Item Parameters

The following parameters are used to construct an address-filter-item:

- Address Type: SOURCE or DESTINATION
- Tag: a *tag-value*
- Address Mask: a *hex-mask*

Each filter-item specifies an address type (either SOURCE or DESTINATION) to match against the type in the packet.

The address mask is a string of numbers entered in hex, which is used in comparing the packet's addresses. The mask is applied to the SOURCE or DESTINATION MAC address of the packet before comparing it against the specified MAC address.

The address mask must be of equal length to the MAC address and specifies the bytes that are to be logically ANDed with the bytes in the MAC address before the equality comparison to the specified MAC address is made. If no mask is specified, it is assumed to be all 1s.

## Filter-List Parameters

The following parameters are used to construct a filter-list:

- Name: an *ASCII-string*
- Filter-item list: *filter-item 1 . . . filter-item n*
- Action: INCLUDE, EXCLUDE, TAG(*n*)

A filter-list is built from one or more filter-items. Each filter-list is given a unique name.

Applying a filter-list to a packet consists of comparing each filter-item in the order in which the filter-items were added to the list. If any filter-item in the list returns a TRUE condition then the filter-list will return its designated action.

## Filter Parameters

The following parameters are used to construct a filter:

- Filter-list names: *ASCII-string 1 . . . ASCII-string n*
- Interface number: an *IFC-number*
- Port direction: INPUT or OUTPUT
- Default action: INCLUDE, EXCLUDE, or TAG
- Default tag: a *tag-value*

A filter is constructed by associating a group of filter-list names with an interface number and assigning an INPUT or OUTPUT designation. The application of a filter to a packet means that each of the associated filter-lists should be applied to packets being received (INPUT) or sent (OUTPUT) on the specified numbered interface.

When a filter evaluates a packet to an INCLUDE condition, the packet is forwarded. When a filter evaluates a packet to an EXCLUDE condition, the packet is dropped. When a filter evaluates to a TAG condition, the packet being considered is forwarded with a tag.

An additional parameter of each filter is the default action, which is the result of non-match for all of its filter-lists. This default action is INCLUDE. It can be set to INCLUDE, EXCLUDE, or TAG. In addition, if the default action is TAG, a tag value is also given.

### Using MAC Filtering Tags

The following list includes some uses of MAC filtering tags

- MAC Address filtering is handled jointly by bandwidth reservation and the MAC Filtering feature (MCF) using tags. A user with bandwidth reservation is able to categorize bridge traffic, for example, by assigning a tag to it.
- The tagging process is done by creating a filter-item in the MAC Filtering configuration console and then assigning a tag to it. This tag is then used to set up a bandwidth class for all packets associated with this tag. Tag values must currently be in the range 1 to 64.
- Once a tagged filter has been created in the MAC Filtering configuration process, the Bandwidth Reservation (BRS) **tag** configuration command is used to assign a BRS tag name (TAG1, TAG2, TAG3, TAG4, or TAG5) to the MAC filter tag number. The BRS tag name is then used on the BRS **assign** configuration command to assign the corresponding MAC filter to a bandwidth traffic class and priority.
- Up to 5 tagged MAC addresses can be set from 1 to 5. TAG1 will be searched for first, then TAG2, all the way to TAG5.

Tags can also refer to “groups” in IP Tunnel. IP Tunnel end-points can belong to any number of groups, with packets assigned to a particular group through the tagging feature of MAC address filtering.



---

## Chapter 4. Configuring and Monitoring MAC Filtering

This chapter describes how to access the MAC Filtering configuration and monitoring prompts and how to use the available commands. It includes the following sections:

- “Accessing the MAC Filtering Monitoring Prompt” on page 58
- “MAC Filtering Monitoring Commands” on page 59
- “MAC Filtering Dynamic Reconfiguration Support” on page 61

---

### Accessing the MAC Filtering Configuration Prompt

Use the **feature** command from the CONFIG process to access the MAC filtering configuration commands. The **feature** command lets you access configuration commands for specific features outside the protocol and network interface configuration processes.

Enter a question mark after the **feature** command to obtain a listing of the features available for your software release. For example:

```
Config> feature ?  
WRS  
BRS  
MCF  
Feature name or number [MCF]?
```

To access the MAC filtering configuration prompt, enter the **feature** command followed by the *feature number* (3) or *short name* (MCF). For example:

```
Config> feature mcf  
MAC Filtering user configuration  
Filter config>
```

Once you access the MAC filtering configuration prompt, you can begin entering specific configuration commands. To return to the CONFIG prompt at any time, enter the **exit** command at the MAC filtering configuration prompt.

---

### MAC Filtering Configuration Commands

This section summarizes the MAC filtering configuration commands. Enter these commands at the Filter config> prompt.

Use the following commands to configure the MAC filtering feature.

*Table 5. MAC Filtering Configuration Command Summary*

Command	Function
? (Help)	Displays all the commands available for this command level or lists the options for specific commands (if available). See “Getting Help” on page xxxii.
Attach	Adds a filter list to a filter.
Create	Creates a filter list or an INPUT or OUTPUT filter.
Default	Sets the default action for the specified filter to EXCLUDE, INCLUDE, or TAG.
Delete	Removes all information associated with a filter list. Also deletes a filter that was created using the create filter command.
Detach	Removes a filter list from a filter.
Disable	Disables MAC Filtering entirely or disables a particular filter.
Enable	Enables MAC Filtering entirely or enables a particular filter.

## Configuring MAC Filtering

Table 5. MAC Filtering Configuration Command Summary (continued)

Command	Function
List	Lists a summary of all the filter lists and filters configured by the user. Also generates a list of attached filter lists for this filter and all subsequent information for the filter.
Move	Reorders the filter lists attached to a specified filter.
Reinit	Re-initializes the entire MAC Filtering system from an updated configuration, without affecting the rest of the router.
Set-Cache	Changes the cache size for a filter.
Update	Adds or deletes information from a specific filter list. Brings you to a menu of appropriate subcommands.
Exit	Returns you to the previous command level. See "Exiting a Lower Level Environment" on page xxxii.

## Attach

Use the **attach** command to add a filter-list to a filter.

A filter is constructed by associating a group of filter-lists with an interface number. A filter-list is built from one or more filter-items.

### Syntax:

**attach** *filter-list-name filter-number*

## Create

Use the **create** command to create a filter-list or an INPUT or OUTPUT filter.

### Syntax:

**create** *list filter-list-name*  
*filter [input or output] interface-number*

#### **list** *filter-list-name*

Creates a filter-list. Lists are named by a unique string (Filter-list-name) of up to 16 characters of the user's choice. This name is used to identify a filter-list that is being built. This name is also used with other commands associated with the filter-list.

#### **filter [input or output]** *interface-number*

Creates a filter and places it on the network associated with the INPUT or OUTPUT direction on the interface given by an interface number. By default this filter is created with no attached filter-lists, has a default action of INCLUDE and is ENABLED.

## Default

Use the **default** command to set the default action for the filter with a specified filter number to exclude, include, or tag.

### Syntax:

**default** *exclude filter-number*  
*include filter-number*  
*tag tag-number filter-number*

#### **exclude** *filter-number*

Sets the default action for the filter with a specified filter number to exclude.

**include** *filter-number*

Sets the default action for the filter with a specified filter number to include.

**tag** *tag-number filter-number*

Sets the default action for the filter with the specified filter number to TAG and sets the associated tag value to tag number.

## Delete

Use the **delete** command to remove all information associated with a filter-list and to free an assigned string as a name for a new filter-list. If filter-list is attached to a filter that has already been created by the user, then this command will display an error message on the console without deleting anything. In addition all filter-items belonging to this list are also deleted

This command also deletes a filter that was created using the **create filter** command.

**Syntax:**

**delete**                                      list *filter-list*  
    filter *filter-number*

**list** *filter-list*

Removes all information associated with a filter-list and frees an assigned string as a name for a new filter-list. The filter-list must be a string entered by a previous **create list** command.

If the filter-list is attached to a filter that has already been created by the user, then this command will display an error message on the console without deleting anything. All filter-items belonging to this list are also deleted when this command is used.

**filter** *filter-number*

Deletes a filter that was created using the **create filter** command.

## Detach

Use the **detach** command to delete a filter-list name (filter-list parameter) from a filter (filter-number parameter).

**Syntax:**

**detach**                                      *filter-list-name filter-number*

## Disable

Use the **disable** command to disable MAC Filtering entirely or to disable a particular filter.

**Syntax:**

**disable**                                      all  
    filter *filter-number*

**all**            Disables MAC Filtering entirely. Filters are still set as ENABLED, however, if they were enabled previously.

**filter** *filter-number*

Disables a particular filter. The filter-number parameter corresponds to the numbers displayed in the **list filters** command.

## Configuring MAC Filtering

### Enable

Use the **enable** command to enable MAC Filtering entirely or to enable a particular filter.

#### Syntax:

```
enable                all  
                        filter filter-number
```

**all** Enables MAC Filtering entirely, although filters themselves may still be set to DISABLED.

**filter** *filter-number*  
Enables a particular filter. The filter-number parameter corresponds to the numbers displayed in the **list filters** command.

### List

Use the **list** command to list a summary of all the filter-lists and filters configured by the user. A list of all the filter-lists attached to a filter is not given. Other information displayed includes:

- A list containing the state of the filtering system (ENABLE, DISABLE)
- The set of configured filter-list records
- Each of the configured filter records.

In addition, the following information is displayed for each filter:

- Filter number
- Interface number
- Filter direction (INPUT, OUTPUT)
- Filter state (ENABLE, DISABLE)
- Filter default action (TAG, INCLUDE, EXCLUDE).

This command also generates a list of attached filter-lists for this filter and all subsequent information for the filter.

#### Syntax:

```
list                all  
_                filter filter-number
```

**all** Displays a summary of all the configured filter-lists and filters.

**filter** *filter-number*  
Generates a list of attached filter-lists for the specified filter and all subsequent information for the filter.

### Move

Use the **move** command to reorder the filter-lists attached to a specified filter (given by filter-number parameter). The list given by Filter-list-name1 is moved immediately before the list given by Filter-list-name2.

#### Syntax:

```
move                filter-list-name1 filter-list-name2 filter-number
```



## Reinit

Use the **reinit** command to re-initialize the entire MAC Filtering system from an updated configuration, without affecting the rest of the router.

**Syntax:**

**reinit**

## Set-Cache

Use the **set-cache** command to change the default cache size (16) to a number in the range 4 to 32768.

**Syntax:**

**set-cache** *cache-size filter-number*

## Update

Use the **update** command to add information to or delete information from a specific filter-list. Using this command with the desired filter-list-name brings you to the Filter filter-list-name Config> prompt for that specific filter-list. From this new prompt you can then change information in the specified list.

The new prompt level is used to add or delete filter-items from filter-lists. The order in which the filter-items are specified for a given filter-list is important as it determines the order in which the filter-items are applied to a packet.

**Syntax:**

**update** *filter-list-name*

---

## Update Subcommands

This section summarizes the MAC filtering configuration subcommands. Enter these subcommands at the Filter filter-list-name config> prompt.

*Table 6. Update Subcommands Summary*

Subcommand	Function
? (Help)	Displays all the commands available for this command level or lists the options for specific commands (if available). See “Getting Help” on page xxxii.
Add	Adds source or destination MAC address filters or a window filter. Adds filter-items to a filter-list.
Delete	Removes filter-items from a filter-list.
List	Lists a summary of all the filter-lists and filters configured by the user. Also generates a list of attached filter-lists for this filter and all subsequent information for the filter.
Move	Reorders the filter-lists attached to a specified filter.
Set-Action	Sets a filter-item to evaluate the INCLUDE, EXCLUDE or TAG (with a tag-number option) condition.
Exit	Returns you to the previous command level. See “Exiting a Lower Level Environment” on page xxxii.

Use the following subcommands to update a filter-list.

## Configuring MAC Filtering

### Add

Use the **add** subcommand to add filter-items to a filter-list. This subcommand specifically lets you add a hexadecimal number to compare against the source or destination MAC address, or a sequence of window data with a mask to compare against a packet data.

The order in which the filter-items are added to a given filter-list is important because it determines the order in which the filter-items are applied to a packet.

Each use of the **add** subcommand creates a filter-item within the filter-list. The first filter-item created is assigned filter-item-number 1, the next one is assigned number 2, and so on. After you enter a successful **add** subcommand, the router displays the number of the filter-item just added.

The first match that occurs stops the application of filter-items, and the filter-list evaluates to INCLUDE, EXCLUDE, or TAG, depending on the designated action of the filter-list. If none of the filter-items of a filter-list produces a match, then the default action (INCLUDE, EXCLUDE or TAG) of the filter is returned.

**Syntax:** **add** *source hex-MAC-addr hex-Mask*  
*destination hex-MAC-addr hex-Mask*  
*window MAC offset-value hex-data hex-mask*  
*window INFO offset-value hex-data hex-mask*

**source** *hex-MAC-addr hex-Mask*

Adds a hexadecimal number to compare against the source MAC address. **hex-MAC-addr** must be an even number of hex digits with a maximum of 16 digits and should be entered without a 0x in front.

The hex-mask parameter must be the same length as hex-MAC-address and is logically ANDed with the designated MAC address in the packet. The default hex-mask argument is to be all binary 1s.

The hex-MAC-addr parameter can be specified in canonical or noncanonical bit order. A canonical bit order is specified as just a hex number (for example, 000003001234). It may also be represented as a series of hex digits with a hyphen (-) between every two digits (for example, 00-00-03-00-12-34).

A noncanonical bit order is specified as a series of hex digits with a colon (:) between every two digits (for example, 00:00:C9:09:66:49). MAC addresses of filter-items will always be displayed using either a hyphen (-) or a colon (:) to distinguish canonical from noncanonical representations.

**destination** *hex-MAC-addr hex-Mask*

Acts identically to the add source subcommand, with the exception that the match is made against the destination rather than the source MAC address of the packet.

**window MAC** *offset-value hex-data hex-mask*

Adds a sliding window filter-item using the specified offset (computed from the beginning of the frame) that matches the hex data with the mask against packet data.

**window INFO** *offset-value hex-data hex-mask*

Similar to the **add window mac** command, except that the offset is computed with respect to the beginning of the information field.

## Delete

Use the **delete** subcommand to remove filter-items from a filter-list. You delete filter-items by specifying the filter-item-number assigned to the item when it was added.

When the **delete** subcommand is used, any gap created in the number sequence is filled in. For example, if filter-items 1, 2, 3, and 4 exist and filter-item 3 is deleted, then filter-item 4 will be renumbered to 3.

### Syntax:

**delete** *filter-item-number*

## List

Use the **list** subcommand to print out a listing of all the filter-item records. The following information about each MAC-Address filter-item is displayed:

- MAC address and address mask in canonical or noncanonical form.
- filter-item numbers
- address type (source or destination)
- filter-list action

### Syntax:

**list** *canonical*  
*noncanonical*  
*mac-address canonical*  
*mac-address noncanonical*  
*window*

#### canonical

Prints out a listing of all the filter-item records within a filter-list, giving the item numbers, the address type (SRC, DST), the MAC address in canonical form, and the address mask in canonical form. It also gives the filter-list action.

#### mac-address canonical

Prints out a listing of all the filter-item records within a filter-list, giving the item numbers, the address type (SRC, DST), the MAC address in canonical form, and the address mask in canonical form. In addition the filter-list action is given.

#### noncanonical

Prints out a listing of all the filter-item records within a filter-list, giving the item numbers, the address type (SRC, DST), the MAC address in noncanonical form, and the address mask in noncanonical form. It also gives the filter-list action.

#### mac-address noncanonical

Prints out a listing of all the filter-item records within a filter-list, giving the item numbers, the address type (SRC, DST), the MAC address in noncanonical form, and the address mask in noncanonical form. It also gives the filter-list action.

## Configuring MAC Filtering

### **window**

Prints out a listing of all the sliding window filter-item records within a filter-list, giving the item numbers, base, offset, data, and mask. It also gives the filter-list action.

## Move

The **move** subcommand reorders filter-items within the filter-list. The filter-item whose number is specified by *filter-item-name1* is moved and renumbered to be just before *filter-item-name2*.

### **Syntax:**

**move** *filter-item-name1 filter-item-name2*

## Set-Action

The **set-action** subcommand lets you set a filter-item to evaluate the INCLUDE, EXCLUDE, or TAG (with a tag-number option) condition. If one of the filter-items of the filter-list matches the contents of the packet being considered for filtering, the filter-list will evaluate to the specified condition. The default setting is INCLUDE.

### **Syntax:**

**set-action** [INCLUDE or EXCLUDE or TAG] *tag-number*

---

## Accessing the MAC Filtering Monitoring Prompt

Use the **feature** command from the GWCON process to access the MAC filtering monitoring commands. The **feature** command lets you access monitoring commands for specific router features outside of the protocol and network interface monitoring processes.

Enter a question mark after the **feature** command to obtain a listing of the features available for your software release. For example:

```
+ feature ?  
WRS  
BRS  
MCF
```

To access the MAC filtering monitoring prompt, enter the **feature** command followed by the feature number (3) or short name (MCF). For example:

```
+ feature mcf  
MAC Filtering user monitoring  
Filter>
```

Once you access the MAC filtering monitoring prompt, you can begin entering specific monitoring commands. To return to the GWCON prompt at any time, enter the **exit** command at the MAC Filtering monitoring prompt.

## MAC Filtering Monitoring Commands

This section summarizes the MAC filtering monitoring commands. Enter these commands at the `Filter>` prompt.

*Table 7. MAC Filtering Monitoring Command Summary*

Command	Function
? (Help)	Displays all the commands available for this command level or lists the options for specific commands (if available). See "Getting Help" on page xxxii.
Clear	Clears the "per filter" statistics listed in the list filter command.
Disable	Disables MAC Filtering globally or on a "per filter" basis.
Enable	Enables MAC Filtering globally or on a "per filter" basis.
List	Lists a summary of statistics and settings for each filter currently running in the router.
Reinit	Re-initializes the entire MAC Filtering system from an updated configuration, without affecting the rest of the router.
Exit	Returns you to the previous command level. See "Exiting a Lower Level Environment" on page xxxii.

Use the following commands to monitor the MAC filtering feature.

### Clear

Use the **clear** command to clear filter statistics.

#### Syntax:

```
clear                all
                        filter filter-number
```

**all**      Clears the statistics listed by the **list all** command.

**filter** *filter-number*  
          Clears the statistics listed by the **list filter** command.

### Disable

Use the **disable** command to disable MAC filtering globally. This command does not individually disable each filter.

The command also disables a filter as specified by filter-number. This filter is disabled without modifying configuration records. If no argument is given, MAC filtering is globally disabled.

#### Syntax:

```
disable              all
                        filter filter-number
```

**all**      Disables MAC filtering globally. This command does not individually disable each filter.

**filter** *filter-number*  
          Disables the filter that is specified by the filter number. This filter is disabled without modifying configuration records. If no filter number is given, MAC filtering is globally disabled.

## Configuring MAC Filtering

### Enable

Use the **enable** command to enable MAC filtering globally. This command does not individually enable each filter.

The command also enables a filter as specified by filter-number. This filter is enabled without modifying configuration records. If no argument is given, MAC filtering is globally enabled.

#### Syntax:

```
enable                all
                        filter filter-number
```

**all** Enables MAC filtering globally. This command does not individually enable each filter.

**filter** *filter-number*  
Enables the filter that is specified by the filter number. This filter is enabled without modifying configuration records. If no filter number is given, MAC filtering is globally enabled.

### List

Use the **list** command to list a summary of statistics and settings for each filter currently running in the router. The following information is displayed for each filter when the **list all** command is used:

- Default action
- Cache size
- Default tag
- State (enabled/disabled)
- Number of packets which have been filtered as INCLUDE, EXCLUDE or TAG.

In addition, the following information is also displayed by the **list filter** command for a specified filter:

- All information displayed by the list all command
- All the filter-lists currently running in this filter including:
  - List name
  - List action
  - List tag
  - Number of packets which have been filtered by each filter-list.

#### Syntax:

```
list                  all
                        filter filter-number
```

**all** Lists statistics and settings for each filter currently running in the router.

**filter** *filter-number*  
Generates statistics and settings for each filter plus all the filter-lists currently running in this filter.

### Reinit

Use the **reinit** command to re-initialize the entire MAC Filtering system from an updated configuration, without affecting the rest of the router.

#### Syntax:

`reinit`

## MAC Filtering Dynamic Reconfiguration Support

This section describes dynamic reconfiguration (DR) as it affects Talk 6 and Talk 5 commands.

### CONFIG (Talk 6) Delete Interface

MAC Filtering supports the CONFIG (Talk 6) **delete interface** command with no restrictions.

### GWCON (Talk 5) Activate Interface

MAC Filtering supports the GWCON (Talk 5) **activate interface** command with the following consideration:

If there are any MAC filters defined for the newly activated interface, then all MAC filters for every interface are reinitialized.

All MAC Filtering interface-specific commands are supported by the GWCON (Talk 5) **activate interface** command.

### GWCON (Talk 5) Reset Interface

MAC Filtering supports the GWCON (Talk 5) **reset interface** command with the following consideration:

If there are any MAC filters defined for the newly reset interface, then all MAC filters for every interface are reinitialized.

All MAC Filtering interface-specific commands are supported by the GWCON (Talk 5) **reset interface** command.

### GWCON (Talk 5) Component Reset Command

MAC Filtering supports the following MAC Filtering-specific GWCON (Talk 5) **reset** command:

#### **GWCON, Feature MCF, Reinit Command**

**Description:**

Dynamically reinitializes all configured MAC filters.

**Network Effect:**

None.

**Limitations:**

None.

All MAC Filtering commands are supported by the **GWCON, feature mcf, reinit** command.

### CONFIG (Talk 6) Activate Command

MAC Filtering supports the following CONFIG (Talk 6) **activate** command:

#### **CONFIG, Feature MCF, Reinit Command**

**Description:**

Dynamically reinitializes all configured MAC filters.

## Configuring MAC Filtering

**Network Effect:**

None.

**Limitations:**

None.

All MAC Filtering commands are supported by the **CONFIG, feature mcf, reinit** command.



---

## Chapter 5. Using WAN Restoral

This chapter includes the following sections:

- “Overview for WAN Restoral, WAN Reroute, and Dial-on-Overflow”
- “Before You Begin” on page 65
- “Configuration Procedure for WAN Restoral” on page 65
- “Secondary Dial Circuit Configuration” on page 66

---

### Overview for WAN Restoral, WAN Reroute, and Dial-on-Overflow

The WAN Restoral, WAN Reroute, and Dial-on-overflow features have similar functions and might be confused. This overview is intended to help you decide which of these functions will be useful to you and to help you find the information you need to configure them.

The configuration commands for all three features are included in the “Configuring WAN Restoral” chapter. For additional information about WAN Reroute and Dial-on-overflow see “Chapter 7. The WAN Reroute Feature” on page 87.

### WAN Restoral

WAN Restoral is the most basic function. When you use WAN Restoral, you configure a primary and a secondary link. In case the primary link fails, the secondary link is started and assumes the characteristics of the primary. You don’t configure any protocol definitions on the secondary link because it uses the protocol definitions from the primary link.

#### For WAN Restoral:

- There is a pairing between a primary and a secondary link.
- You can configure only one primary to use a specific secondary link.
- You don’t configure protocol definitions (for example: protocol addresses) on the secondary link.
- The primary link can be a PPP serial interface or a multilink PPP interface. It can not be a PPP dial circuit interface.
- The secondary link must be a PPP dial circuit or a multilink PPP interface.
- You must enable the WRS feature using the **enable wrs** command.
- You must enable the primary/secondary pair using the **enable secondary-circuit** command.

**Note:** When BRS is configured on a primary link and the primary link is part of a primary-secondary pair for WAN Restoral, you must configure BRS on the secondary link. Typically when WAN Restoral is configured, the secondary link takes the identify of the primary link. However, this is not true for BRS; therefore, BRS needs to be configured on both the primary and secondary link.

### WAN Reroute

WAN Reroute is a more advanced function. When you use WAN Reroute, you configure a primary and an alternate link. In case the primary link fails, the alternate link is started. The routing protocols (for example, RIP or OSPF) detect the newly available link and adjust the routes that are used for forwarding packets.

#### For WAN Reroute:

## Using WAN Restoral

- There is a pairing between a primary and an alternate link.
- You may configure multiple primary links to use the same alternate link.
- You must configure protocol definitions on the alternate link.
- The primary link may be any link on which you can configure routable protocols (e.g. IP, IPX). For example, the primary link may be a LAN interface, a PPP, Frame Relay, or X.25 serial interface, or a PPP or Frame Relay dial circuit. The following are examples of interface types that cannot be primary links: SDLC serial interfaces, SRLY serial interfaces, and base nets like V.25 bis and ISDN.
- The alternate link may be any link on which you can configure routable protocols (e.g. IP, IPX) and the datalink type of the alternate link need not match the datalink type of the primary link. For example, the alternate link may be a LAN interface, a PPP, Frame Relay, or X.25 serial interface, or a PPP or Frame Relay dial circuit. The following are examples of interface types that cannot be alternate links: SDLC serial interfaces, SRLY serial interfaces, and base nets like V.25 bis and ISDN.
- If the primary link is a dial circuit, then it cannot be a dial-on-demand dial circuit. To configure the dial circuit so that it is not a dial-on-demand circuit, you must configure it with **set idle 0** at that dial `Circuit Config>` prompt. Refer to “Configuring and Monitoring Dial Circuits” in the *Access Integration Services Software User’s Guide* for more information.  
I.430, I.431 and Channelized T1/E1 dial circuits are implicitly fixed, and therefore can be used as a WRS primary.

**Note:** I.430/I.431 and Channelized T1/E1 dial circuits can be used as WRS primary without any explicit configuration.

- You must enable the WRS feature using the **enable wrs** command.
- You must enable the primary/alternate pair using the **enable alternate-circuit** command.
- You may optionally configure stabilization times, routing-stabilization times, and start-and-stop-time-of-day-revert-back times to control the switching back to the primary link.
- If the alternate link is X.25, you should use the **national-personality set disconnect-procedure active** command when configuring the X.25 interface of the router that has WAN Reroute enabled and use the **national-personality set disconnect-procedure passive** command when configuring the X.25 interface of the other router.

## Dial-on-overflow

Dial-on-overflow is similar to WAN Reroute, but does not require failure of the primary to start the alternate link. Instead, the utilization of the primary link is monitored, and if a threshold is exceeded, the alternate link is started. Also, not all protocols are brought up on the alternate link. Only IP is brought up on the alternate link, and other protocols continue to use the primary link unless the primary link goes down.

If the primary link goes down, WAN Reroute takes over and any protocols configured on the alternate interface can start detecting and using routes on the alternate interface.

### For Dial-on-overflow:

- Dial-on-overflow uses the primary/alternate pairing of a WAN Reroute pair.

- You must configure a WAN reroute pair to use Dial-on-overflow, and all the restrictions of WAN Reroute configuration apply.
- The primary link of a WAN Reroute pair that will be used for Dial-on-overflow must be Frame Relay.
- You must use the OSPF routing protocol to use Dial-on-overflow.
- You must use the **enable dial-on-overflow** command to configure add-threshold and drop-threshold, the bandwidth monitoring interval, and the minimum alternate up time.
- Stabilization times, routing-stabilization times, and start-time-of-day-revert-back and stop-time-of-day-revert-back times do not affect the operation of dial-on-overflow.

For more information about WAN Reroute see “Chapter 7. The WAN Reroute Feature” on page 87.

---

### Before You Begin

Before you configure WAN Restoral, you must have the following:

1. A primary serial interface (leased line) configured for PPP. You can use any serial interface on the router.
2. An interface with the associated dial circuits configured on the router. You can use an ISDN interface or a V.25 bis interface as the base net.
3. A secondary dial circuit configured to dial when the primary interface goes down. To configure a dial circuit to do this, set the idle timer to zero using the **set idle** command at that dial `Circuit Config>` prompt. This command prevents the dial circuit from being dial-on-demand.
4. A secondary dial circuit at one end of the link configured to send calls only. Use the **set calls outbound** command at the `Circuit Config>` prompt.

**Note:** Do not configure any protocol addresses on the secondary interface. The protocol assignments for the primary interface are used on the secondary link (dial circuit) when it is active.

5. A secondary dial circuit at the other end of the link configured to receive calls only. Use the **set calls inbound** command at the `Circuit Config>` prompt.

---

### Configuration Procedure for WAN Restoral

This section describes the steps required to configure WAN Restoral. Before you begin, use the **list device** command at the `Config>` prompt to list the interface numbers of different devices.

Follow these steps to configure WAN Restoral on the router:

1. Display the `WRS Config>` prompt by entering the **feature wrs** command at the `Config>` prompt. For example:

```
Config>feature wrs
WAN Restoral user configuration
WRS Config>
```

2. Assign a secondary dial circuit to the primary interface. This dial circuit will back up the primary interface. For example:

```
WRS Config>add secondary-circuit
Secondary interface number [0]? 3
Primary interface number [0]? 1
```

3. Enable WAN Restoral on the secondary dial circuit that you added. For example:

## Using WAN Restoral

```
WRS Config>enable secondary-circuit
Secondary interface number [0]? 3
```

4. Globally enable WAN Restoral on the router. For example:  
WRS Config>enable wrs
5. Restart the router for configuration changes to take effect.

## Secondary Dial Circuit Configuration

To configure a dial circuit:

1. Determine the dial-circuit interface number: To do this, type:

```
Config> list device
```

If no PPP dial-circuit interface is listed, add a dial-circuit interface by typing:

```
Config> add device dial-circuit
```

```
Adding device as interface 3
Defaulting Data-link protocol to PPP
Use "net 3" command to configure circuit parameters
```

2. Configure the secondary interface (dial circuit) to have the same datalink type as the primary interface (PPP) from the Config> prompt as follows:

```
Config> set data PPP
Interface Number [0]? 3
```

3. Access the dial circuit configuration prompt (Circuit Config>) by entering **network interface#**.

```
Config> network 3
```

4. Select the base net interface for the dial circuit. The base net can be V.25 bis, or ISDN.

```
Circuit Config> set net 2
```

5. Set the dial circuit idle timer to 0 (0=fixed) as follows:

```
Circuit Config> set idle 0
```

6. Set one end of the backup connection to receive calls (for example, router A) as follows:

```
Circuit Config> set calls inbound
```

7. Set the other end of the backup connection to initiate calls (for example, router B) as follows:

```
Circuit Config> set calls outbound
```

### Notes:

1. Do not use the **set calls both** command. Setting these individually will help prevent the collisions of incoming and outgoing connection attempts.
2. Do not configure any forwarder (for example, IP, IPX, etc.) addresses on the dial circuit. The protocol assignments for the primary interface are used on the secondary interface (dial circuit) when it is active.
3. For ISDN configuration instructions, see "Using the ISDN Interface" in *Access Integration Services Software User's Guide*.
4. For V.25 bis configuration instructions, see "Using the V.25 bis Interface" in *Access Integration Services Software User's Guide*.

---

## Chapter 6. Configuring and Monitoring WAN Restoral

This chapter describes the WAN Restoral configuration and operational commands. It includes the following sections:

- “Accessing the WAN Restoral Interface Monitoring Process” on page 74
- “WAN Restoral Monitoring Commands” on page 74
- “WAN Restoral and WAN Reroute Dynamic Reconfiguration Support” on page 84

**Note:** Refer to “Configuring and Monitoring Dial Circuits” in the *Access Integration Services Software User’s Guide* for information about configuring dial circuits. A dial circuit can be used as an interface when configuring WAN Reroute.

---

### WAN Restoral, WAN Reroute, and Dial-on-Overflow Configuration Commands

The WAN Restoral configuration commands allow you to create or modify the WAN Restoral interface configuration. This section summarizes and explains the WAN Restoral configuration commands.

Table 8 lists the WAN Restoral configuration commands and their function. Enter these commands at the WRS Config> prompt. To access WRS Config>, enter **feature wrs** at the Config> prompt.

*Table 8. WAN Restoral Configuration Commands Summary*

Command	Function
? (Help)	Displays all the commands available for this command level or lists the options for specific commands (if available). See “Getting Help” on page xxxii.
Add	Adds a mapping of primary-to-secondary (for WAN Restoral) or primary-to-alternate (for WAN Reroute).
Disable	Disables WRS, an individual secondary-circuit mapping, or alternate-circuit mapping.
Enable	Enables WRS, an individual secondary-circuit mapping, or alternate-circuit mapping.
List	Displays the current Restoral configuration.
Remove	Removes a primary to secondary mapping or a primary to alternate mapping created by add.
Set	Sets the values for the stabilization, route-stabilization, and time-of-day-revert-back timers.
Exit	Returns you to the previous command level. See “Exiting a Lower Level Environment” on page xxxii.

### Add

Use the **add** command to identify a secondary or an alternate dial-circuit or leased link interface for a primary serial link.

#### Syntax:

```
add                alternate-circuit  
                   secondary-circuit
```

#### **alternate-circuit**

The **add alternate-circuit** command binds an alternate interface to a primary interface for WAN Reroute purposes. You can assign multiple

## Configuring WAN Restoral

primaries to a single alternate interface. The alternate link type need not be the same as the primary link type (for example, the alternate link type can be a PPP dial circuit and the primary link type can be a Frame Relay leased line).

### Example:

```
WRS Config>add alt
Alternate interface number [0]? 6
Primary interface number [0]? 1
```

### Alternate interface number

This is the interface number previously assigned to the alternate interface. Any LAN interface, PPP, Frame Relay, or X.25 serial interface, or a PPP or Frame Relay dial circuit is an eligible alternate interface. The default is 0.

### Primary interface number

This is the interface number of the primary interface previously assigned when the device was added. A primary interface can be any previously defined LAN interface, PPP, Frame Relay, or X.25 serial interface, or a PPP or Frame Relay dial circuit. The default is 0.

### secondary-circuit

The **add secondary-circuit** command binds a secondary interface to a primary interface for WAN Restoral purposes. Both interfaces must have previously been configured. You can only assign one secondary interface to a primary and vice-versa.

### Example:

```
WRS Config>add secondary-circuit
Secondary interface number [0]? 4
Primary interface number [0]? 1
```

### Secondary interface number

This is the dial circuit interface number previously assigned to the secondary interface when the device was added. Any PPP dial circuit or Multilink PPP interface can be a secondary interface. The default is 0.

### Primary interface number

This is the interface number of the primary interface previously assigned when the device was added. A primary interface can be any previously defined leased-line running PPP. The default is 0.

## Disable

Use the **disable** command to disable the WAN Restoral function, or to disable a primary/secondary pairing for WAN Restoral, or to disable a primary/alternate pairing for WAN Reroute, or to disable Dial-on-overflow for a primary/alternate pairing.

### Syntax:

```
disable                alternate-circuit
                        dial-on-overflow
                        secondary-circuit
                        wrs
```

### **alternate-circuit** *interface#*

Disables the primary/alternate pairing for WAN Reroute.

### Example:

```
WRS Config> disable alternate-circuit
Alternate interface number [0]? 6
```

### Alternate interface number

This is the number of the alternate interface previously configured with the **add alternate-circuit** command. The default is 0.

### dial-on-overflow *alt-intfc#*

Disables dial-on-overflow for all primary/alternate pairings using a specified alternate.

### Example:

```
WRS Config> disable dial-on-overflow
alternate interface number [0]? 6
```

### Alternate interface number

This is the number of the alternate interface previously configured with the **add alternate-circuit** command. The default is 0.

### secondary-circuit *interface#*

Disables the restoral of a particular primary interface by its associated secondary interface until the next **enable secondary-circuit** command at the WRS console. Both interfaces must have been previously configured and bound together in the WRS configuration.

### Example:

```
WRS Config> disable secondary-circuit
Secondary interface number [0]? 3
```

### Secondary interface number

This is the number of the secondary interface previously configured with the **add secondary-circuit** command. The default is 0.

**wrs** Disables the WAN Restoral feature globally on the router. This means that WAN Reroute and Dial-on-overflow are also disabled.

## Enable

Use the **enable** command to enable the WAN Restoral function, to enable a primary/secondary pairing for WAN Restoral, to enable a primary/alternate pairing for WAN Reroute, or to enable dial-on-overflow for a primary/alternate pairing.

### Syntax:

```
enable                                alternate-circuit
                                         dial-on-overflow
                                         secondary-circuit
                                         wrs
```

### alternate-circuit *interface#*

Enables an alternate circuit

### Example:

```
WRS Config>enable alternate-circuit
Alternate interface number [0]? 6
```

### Alternate interface number

This is the number of the alternate interface previously configured with the **add alternate-circuit** command. The default is 0.

## Configuring WAN Restoral

### dial-on-overflow

Enables dial-on-overflow and allows you to set parameters that control how dial-on-overflow works.

#### Example:

```
WRS>enable dial-on-overflow
```

For dial-on-overflow, only IP traffic can overflow to the alternate interface.

```
Primary interface number [0]? 1
add-threshold (1-100% utilization) [90]?
drop-threshold(0-99% utilization) [60]?
bandwidth test interval(10-200 seconds) [15]?
minimum time to keep the alternate up (20-21600 sec.) [300]?
Dial-on overflow is enabled.
Remember to configure the primary interface's line speed!
```

#### Primary interface number

This is the interface number of the primary interface for which you are enabling dial-on-overflow. The default is 0.

#### add-threshold

Determines when an alternate interface will be brought up for additional bandwidth. This value must be expressed as a percentage of the primary interface's configured line speed. The default is 90%.

#### drop-threshold

Determines when an alternate interface is no longer needed for additional bandwidth. This value must be expressed as a percentage of the primary interface's configured line speed. The default is 60%.

#### bandwidth monitoring interval

Determines how often the primary interface's bandwidth is monitored for the *add-threshold* and *drop-threshold*. The default is 15 seconds.

#### Minimum time to keep alternate up

This time period needs to include enough time for the routers to establish the new route when IP traffic on the local router is rerouted to the alternate interface. The default is 5 minutes.

### secondary-circuit *interface#*

Enables the restoral of a primary link by the indicated secondary link.

#### Example:

```
WRS Config>enable secondary-circuit
Secondary interface number [0]? 3
```

#### Secondary interface number

This is the number of the secondary interface previously configured with the **add secondary-circuit** command. The default is 0.

**wrs** Enables the function of the WAN Restoral feature on the router. This means that if WAN Reroute and Dial-on-overflow are configured they are also enabled.

## List

Use the **list** command to display global configuration information for the feature and display configuration information for WAN Restoral primary-secondary pairs, WAN Reroute primary-alternate pairs, and Dial-on-Overflow.

#### Syntax:

```
list
```



### Example:

```
WRS Config>list all
WAN Restoral is enabled.
Default Stabilization Time: 0 seconds
Default First Stabilization Time: 0 seconds
```

Primary Interface	Secondary Interface	Secondary Enabled					
4 - WAN PPP	7 - PPP Dial Circuit	No					
Primary Interface	Alternate Interface	Alt. Enabled	1st Stab	Subseq Stab	TOD Start	Revert Stop	Back Stab
1 - WAN Frame Re	2 - WAN Frame Relay	Yes	dfilt	dfilt	Not Set	Not Set	15

```
Dial-on-overflow is enabled.
Primary add- drop- test minimum
Interface threshold threshold interval alt up time
-----
1 29% 20% 15 sec. 300 sec.
```

## Remove

Use the **remove** command to delete the mapping of an alternate interface or secondary (backup) interface to the primary interface.

### Syntax:

```
remove alternate-circuit
secondary-circuit
```

**alternate-circuit** *alternate-interface# primary-interface#*

Removes the mapping of a alternate (backup) interface to the primary interface for WAN Reroute. Both interfaces must have been previously assigned and bound together using the **add alternate-circuit** command.

#### Alternate-interface#

This is the number of the alternate interface previously configured with the **add alternate-circuit** command. The default is 0.

#### Primary-interface#

This is the interface number of the primary interface previously bound to the alternate being removed. The default is 0.

### Example:

```
WRS Config> remove alternate-circuit
Alternate interface number [0]? 3
Primary interface number [0]? 1
```

**secondary-circuit** *secondary-interface# primary-interface#*

Removes the mapping of a secondary (backup) interface to the primary interface for WAN Restoral. Both interfaces must have been previously assigned and bound together using the **add secondary-circuit** command.

#### Secondary-interface#

This is the number of the secondary interface previously configured with the **add secondary-circuit** command. The default is 0.

#### Primary-interface#

This is the interface number of the primary interface previously bound to the secondary being removed. The default is 0.

### Example:

## Configuring WAN Restoral

```
WRS Config> remove secondary-circuit
Secondary interface number [0]? 3
Primary interface number [0]? 1
```

## Set

Use the **set** command to set the parameters for WAN Reroute.

### Syntax:

```
set ?                                default
                                         first-stabilization
                                         routing-stabilization
                                         stabilization
                                         start-time-of-day-revert-back
                                         stop-time-of-day-revert-back
```

### default

Use the **set default** command to set the defaults to be used by links that do not have configured stabilization and first-stabilization times.

### first-stabilization

Sets the default first-stabilization value to be used for links for which a first-stabilization time was not configured.

```
WRS Config>set default first
Default first primary stabilization time (0 - 3600 seconds) [0]? 20
```

### stabilization

Sets the default stabilization value to be used for links for which a stabilization time was not configured.

```
WRS Config>set default stab
Default primary stabilization time (0 - 3600 seconds) [0]? 30
```

### first-stabilization

Sets the number of seconds at router initialization before routing for this primary link is switched to the alternate link if the primary link is not up.

### Example:

```
WRS Config>set first
Primary interface number [0]? 1
First primary stabilization time (0 - 3600 seconds -1 = default) [-1]?
```

### Primary interface number

This is the primary interface number of the primary interface for which you are setting first-stabilization. The default is 0.

### First primary stabilization time

The stabilization time for this primary interface. The default is 1.

### routing-stabilization

Sets the routing-stabilization value. This parameter defines the number of seconds that both the primary link and the alternate link remain up after the primary link has been found to be up and the stabilization timer, if any, has expired. The routing-stabilization time is provided so that routing protocols such as OSPF or RIP have enough time to recognize the availability of the new route. Without the routing-stabilization timer, traffic can be interrupted for several seconds while the alternate route has been disabled and the primary route has not yet been discovered.

If the alternate link was up prior to the reroute, the alternate link remains up and the routing-stabilization timer is ignored. If the alternate link went down

prior to the reroute or during the reroute, the alternate link remains down and the routing-stabilization timer and the stabilization timer are both ignored.

```
WRS Config>set routing-stabilization
Primary interface number [0]? 1
Routing stabilization timer (0 - 3600 seconds) [0]?
```

### Primary interface number

**Valid Values:** 0 to the number of interfaces configured on the router

**Default Value:** 0

### Routing-stabilization timer

**Valid Values:** 1 to 3600 seconds

**Default Value:** 0

### stabilization

Sets the number of seconds required after the primary link is first detected to be up before the process of re-initializing routing on the primary link begins. When the stabilization timer expires, the alternate link will be brought down unless the routing-stabilization timer has been configured. The routing-stabilization timer will start as soon as the stabilization timer expires and will keep both the primary and the alternate links up long enough to maintain the traffic on the alternate link while the routing protocols such as OSPF and RIP reestablish the route over the primary link.

### Example:

```
WRS Config>set first
Primary interface number [0]? 1
Primary stabilization time (0 - 3600 seconds -1 = default) [-1]?
```

### Primary interface number

This is the primary interface number of the primary interface for which you are setting stabilization. The default is 0.

### Primary stabilization time

The stabilization time for the primary interface. The default is 1.

### start-time-of-day-revert-back

The earliest time of the day the router can switch back to the primary route. The router can revert back to the primary any time between the start-time-of-day-revert-back time and the stop-time-of-day-revert-back time. Reverting back to the primary will only occur if the primary is up and the stabilization parameters are met. The default is 0.

### Example:

```
WRS Config>set start
Primary interface number [0]? 1
Time-of-Day revert back window start (1 - 24 hours, 0 = not configured) [0] 3
Start time-of-day revert back configured. Remember to configure stop time-of-day
```

### Primary interface number

This is the primary interface number of the primary interface for which you are setting first-stabilization. The default is 0.

### Time-of-day-revert-back-window start

This time marks the beginning time for the revert back window. The router can revert back to the primary interface any time between the start-time-of-day-revert-back time and the stop-time-of-day-

## Configuring WAN Restoral

revert-back time. Reverting back to the primary interface will only occur if the primary interface is up and the stabilization parameters are met. The default is 1.

### stop-time-of-day-revert-back

This time marks the ending time for the revert back window. The router can revert back to the primary interface any time between the start-time-of-day-revert-back time and the stop-time-of-day-revert-back time. Reverting back to the primary interface will only occur if the primary interface is up and the stabilization parameters are met. The default is 1.

#### Example:

```
WRS Config>set stop
Primary interface number [0]? 1
Time-of-Day revert back window stop (1 - 24 hours, 0 = not configured) [0]?5
```

#### Primary interface number

This is the primary interface number of the primary interface for which you are setting first-stabilization. The default is 0.

#### Time-of-day-revert-back-window stop

This time marks the ending time for the revert back window. The router can revert back to the primary interface any time between the start-time-of-day-revert-back time and the stop-time-of-day-revert-back time. Reverting back to the primary interface will only occur if the primary interface is up and the stabilization parameters are met. The default is 1.

---

## Accessing the WAN Restoral Interface Monitoring Process

To access the WAN Restoral interface monitoring process, enter the following command at the GWCON (+) prompt:

```
+ feature wrs
```

---

## WAN Restoral Monitoring Commands

The WAN Restoral (WRS) monitoring commands allow you to monitor the state of WAN Restoral primary-secondary pairs, WAN Reroute primary-alternate pairs, and Dial-on-Overflow. Any modifications to the operational state of WAN Restoral, WAN Reroute, and Dial-on-Overflow made through the monitoring interface are not maintained across router restarts.

Access the WRS prompt by entering **feature wrs** at the GWCON (+) prompt. Table 9 lists the WRS commands and their functions, and the following sections explain the commands.

*Table 9. WAN Restoral Monitoring Commands*

Command	Function
? (Help)	Displays all the commands available for this command level or lists the options for specific commands (if available). See "Getting Help" on page xxxii.
Clear	Clears the monitoring statistics displayed using the <b>list</b> command.
Disable	Disables the WRS, or an individual secondary, or alternate, or dial-on-overflow.
Enable	Enables the WRS, or an individual secondary, or alternate, or dial-on-overflow.
List	Displays the monitoring information on one or all alternate or secondary circuits.



## Configuring WAN Restoral

does not disable the interface itself. It disables only the current call (that is, causes any active call to be disconnected.) To disable use of the secondary circuit, you need to **disable secondary-circuit** at the WAN Restoral monitoring prompt and disable the secondary interface at the top level GWCON prompt.**Example:**

```
WRS>disable secondary-circuit
Secondary interface number [0]? 3
```

### Secondary interface number

This is the number of the secondary interface previously configured with the **add secondary-circuit** command. The default is 0.

**wrs** Disabling WRS disables WAN Restoral, WAN Reroute, and Dial-on-overflow on the router until the next **restart**, **reload**, or **enable WRS** command.

## Enable

Use the **enable** command to enable the WAN Restoral interface, enable the restoral of a primary link by a secondary circuit, enable an alternate circuit, or enable dial-on-overflow.

### Syntax:

```
enable                alternate-circuit
                        dial-on-overflow
                        secondary-circuit
                        wrs
```

### alternate-circuit

Enables the primary/alternate pairings for WAN Reroute for all pairings using the specified alternate.

Example:

```
WRS> enable alternate-circuit
Alternate circuit number [0]? 3
```

### Alternate circuit number

This is the interface number of the alternate circuit. The default is 0.

### dial-on-overflow

Enables dial-on-overflow and allows you to set parameters that control dial-on-overflow. Optionally, allows you to cause the IP protocol to be switched immediately to the alternate, as if the add threshold had been crossed.

Example:

```
WRS> dial-on-overflow
```

```
For dial-on-overflow, only IP traffic can overflow to the alternate interface.
Primary interface number [0]? 1
add-threshold (1-100% utilization) [90]?
drop-threshold(0-99% utilization) [60]?
bandwidth test interval(10-200 seconds) [15]?
minimum time to keep the alternate up (20-21600 sec.) [300]?
Dial-on overflow is enabled.
Remember to configure the primary interface's line speed!
```

```
Do you want to switch IP traffic to the alternate now?(Yes or [No]):
WRS>
```

### secondary-circuit

Enables the restoral of a primary link by the indicated secondary link.

Example:

```
WRS> enable secondary-circuit
Secondary interface number [0]? 3
```

### Secondary interface number

This is the number of the secondary interface previously configured with the **add secondary-circuit** command. The default is 0.

**wrs** Enables the function of the WAN Restoral feature on the router. This feature needs to be enabled in order to do WAN Restoral, WAN Reroute, or Dial-on-overflow.

## Set

Use the **set** command to set the parameters for WAN Reroute.

### Syntax:

```
set ?                               default
                                       first-stabilization
                                       routing-stabilization
                                       stabilization
                                       start-time-of-day-revert-back
                                       stop-time-of-day-revert-back
```

### default

Use the **set default** command to set the defaults to be used by links that do not have configured stabilization and first-stabilization times.

#### Example:

```
WRS Config>set default ?
FIRST-STABILIZATION
STABILIZATION
```

### first-stabilization

Sets the default first-stabilization value to be used for links for which a first-stabilization time was not configured.

```
WRS Config>set default first
Default first primary stabilization time (0 - 3600 seconds) [0]? 20
```

### stabilization

Sets the default stabilization value to be used for links for which a stabilization time was not configured.

```
WRS Config>set default stab
Default primary stabilization time (0 - 3600 seconds) [0]? 30
```

### first-stabilization

Sets the number of seconds at router initialization before routing for this primary link is switched to the alternate link if the primary link is not up.

#### Example:

```
WRS Config>set first
Primary interface number [0]? 1
First primary stabilization time (0 - 3600 seconds -1 = default) [-1]?
```

### Primary interface number

This is the primary interface number of the primary interface for which you are setting first-stabilization. The default is 0.

### First primary stabilization time

The stabilization time for this primary interface. The default is 1.

## Configuring WAN Restoral

### routing-stabilization

Sets the routing-stabilization value. This parameter defines the number of seconds that both the primary link and the alternate link remain up after the primary link has been found to be up and the stabilization timer, if any, has expired. The routing-stabilization time is provided so that routing protocols such as OSPF or RIP have enough time to recognize the availability of the new route. Without the routing-stabilization timer, traffic can be interrupted for several seconds while the alternate route has been disabled and the primary route has not yet been discovered.

If the alternate link was up prior to the reroute, the alternate link remains up and the routing-stabilization timer is ignored. If the alternate link went down prior to the reroute or during the reroute, the alternate link remains down and the routing-stabilization timer and the stabilization timer are both ignored.

```
WRS Config>set routing-stabilization
Primary interface number [0]? 1
Routing stabilization timer (0 - 3600 seconds) [15]?
```

#### Primary interface number

**Valid Values:** 0 to the number of interfaces configured on the router

**Default Value:** 0

#### Routing-stabilization timer

**Valid Values:** 1 to 3600 seconds

**Default Value:** 0

### stabilization

Sets the number of seconds required after the primary link is first detected to be up before the process of re-initializing routing on the primary link begins. When the stabilization timer expires, the alternate link will be brought down unless the routing-stabilization timer has been configured. The routing-stabilization timer will start as soon as the stabilization timer expires and will keep both the primary and the alternate links up long enough to maintain the traffic on the alternate link while the routing protocols such as OSPF and RIP reestablish the route over the primary link.

#### Example:

```
WRS Config>set first
Primary interface number [0]? 1
Primary stabilization time (0 - 3600 seconds -1 = default) [-1]?
```

#### Primary interface number

This is the primary interface number of the primary interface for which you are setting stabilization. The default is 0.

#### Primary stabilization time

The stabilization time for the primary interface. The default is 1.

### start-time-of-day-revert-back

Sets the earliest time of the day that the router can switch back to the primary route. The router can revert back to the primary any time between the start-time-of-day-revert-back time and the stop-time-of-day-revert-back time. Reverting back to the primary will only occur if the primary is up and the stabilization parameters are met. The default is 0.

#### Example:



```
WRS Config>set start
Primary interface number [0]? 1
Time-of-Day revert back window start (1 - 24 hours, 0 = not configured) [0] 3
Start time-of-day revert back configured. Remember to configure stop time-of-day
```

### Primary interface number

This is the primary interface number of the primary interface for which you are setting first-stabilization. The default is 0.

### Time-of-day-revert-back-window start

This time marks the beginning time for the revert back window. The router can revert back to the primary interface any time between the start-time-of-day-revert-back time and the stop-time-of-day-revert-back time. Reverting back to the primary interface will only occur if the primary interface is up and the stabilization parameters are met. The default is 1.

### stop-time-of-day-revert-back

This time marks the ending time for the revert back window. The router can revert back to the primary interface any time between the start-time-of-day-revert-back time and the stop-time-of-day-revert-back time. Reverting back to the primary interface will only occur if the primary interface is up and the stabilization parameters are met. The default is 1.

### Example:

```
WRS Config>set stop
Primary interface number [0]? 1
Time-of-Day revert back window start (1 - 24 hours, 0 = not configured) [0]?
5
```

### Primary interface number

This is the primary interface number of the primary interface for which you are setting first-stabilization. The default is 0.

### Time-of-day-revert-back-window stop

This time marks the ending time for the revert back window. The router can revert back to the primary interface any time between the start-time-of-day-revert-back time and the stop-time-of-day-revert-back time. Reverting back to the primary interface will only occur if the primary interface is up and the stabilization parameters are met. The default is 1.

## List

Use the **list** command to display monitoring information on one or all WAN Restoral primary-secondary pairs or one or all WAN Reroute primary-alternate pairs.

### Syntax:

```
list                all
                    alternate-circuit
                    secondary-circuit
                    summary
```

**all** Provides summary information, followed by the specific information, for each secondary interface.

### Example:

```
list all
WAN Restoral/Re-route is enabled with 2 circuits configured
Total restoral attempts =          7 completions =          7
Total packets forwarded =          39
Longest completed restoral period in hrs:min:sec    0:03:27
```

## Configuring WAN Restoral

Total overflow attempts =		20 completions =		19	
Longest completed overflow period		in hrs:min:sec		0:05:00	
Primary Net Interface	Secondary Net Interface	Restoral Enabled	Restoral Active	Current/Longest Duration	
4 PPP/0	7 PPP/1	No	No	00:03:27/ 00:06:00	
Primary Net Interface	Alternate Net Interface	Re-route/ Overflow Enabled	Re-route/ Overflow Active	Recent Reroute/Overflow Duration	
1 FR/0	2 FR/1	Yes/Yes	No /No	00:00:56/ 00:05:00	

### Total restoral attempts

The number of times the primary link failed, causing the router to try to bring up a secondary link.

### Completions

The number of successful restoral attempts when the secondary link came up and was used.

### Total packets forwarded

The total number of packets forwarded across the secondary interface. It is the sum of both directions, and is cumulative over all successful restores, until the restart or clear restoral-statistics command is issued.

### Longest Completed Restoral Period

This field displays in hours, minutes, and seconds the longest amount of time a restoral was in operation, not counting any current usage.

### Total Overflow Attempts

The number of attempts due to an overflow.

### Completions

The number of successful overflow attempts when the secondary link came up and was used.

### Longest Completed Overflow Period

Displays in hours, minutes, and seconds the longest amount of time an overflow was in operation, not counting any current usage.

### Primary Net Interface

The interface that is being backed up by its associated secondary interface.

### Secondary Net Interface

The dial circuit that is being used to back up the associated primary interface.

### Restoral Enabled

Indicates that restoral of this primary interface is currently enabled.

### Restoral Active

Indicates whether restoral is active (Yes or No).

### Current/Longest Duration

Indicates in hours, minutes, and seconds the current and longest duration the secondary net interface was up.

### Primary Net Interface

The interface that is being backed up by its associated alternate interface.

### Alternate Net Interface

The interface that is being used as an alternate back up the associated primary interface.

### Re-route/Overflow Enabled

Indicates whether reroute and overflow are enabled (Yes or No).

### Re-route/Overflow Active

Indicates whether reroute and overflow are active (Yes or No).

### Recent Re-route Overflow Duration

Indicates in hours, minutes, and seconds the recent reroute and overflow duration of the alternate net interface.

### Alternate-circuit

Provides totals for an alternate circuit. Allows the monitoring operator to retrieve the WAN Reroute state and associated statistics for each alternate interface and its associated primary mapping.

#### Example:

```
WRS>li alt 7
Primary 1:FR/0 Frame Relay V.35/V.36
Alternate 7:PPP/1 Point to Point V.25bis Dial Circuit
reroute Enabled, currently inactive
overflow Enabled, currently inactive
Primary first stabilization time: default (0 seconds)
Primary stabilization time: default (0 seconds)
Routing-stabilization time: 15 seconds
Time-of-day revert back not configured: start = 0, stop = 0
Restored 0 times (0 attempts)
Overflow 0 times (0 attempts)
```

### Primary Interface

The interface that is being backed up by this associated alternate interface.

### Alternate Interface

The dial circuit that is being used to back up the associated primary interface.

### Reroute Enabled

Indicates whether reroute of this primary interface is currently enabled.

### Overflow Enabled

Indicates whether overflow of this primary interface is currently enabled.

### Primary first stabilization

The number of seconds at router initialization before routing for this primary link is switched to the alternate link if the primary link is not up.

### First stabilization

The number of seconds required after the primary link is first detected to be up before routing is switched back from the alternate link to the primary link. Routing over the alternate link continues until the primary link remains up for this number of seconds.

### Routing stabilization

The number of seconds required after routing is switched back to the primary link before the alternate link is taken down. During this time both the primary and the alternate links remain up. This interval is provided to allow routing protocols such as OSPF and RIP time to recognize the availability of the route over the primary interface.

## Configuring WAN Restoral

### Time-of-day revert back

The time of the day the router can switch back to the primary route. The router can revert back to the primary any time between the start-time-of-day-revert-back time and the stop-time-of-day-revert-back time. Reverting back to the primary will only occur if the primary is up and the stabilization parameters are met. The default is 0.

### Restored times

The number of attempts to reroute the primary interface.

### Overflow times

The number of dial-on-overflow attempts.

### secondary-circuit

Provides totals for each secondary circuit. Allows the monitoring operator to retrieve the WAN Restoral state and associated statistics for each secondary interface and its associated primary mapping.

#### Example:

```
list secondary-circuit
```

```
Secondary interface number [0]? 1
```

Primary Interface	Secondary Interface	Secondary Enabled
1 PPP/0 Point to Poi	3 PPP/1 Point to Poi	Yes

```
Router primary interface state = Up  
Router secondary interface state = Available  
Restoral Statistics:
```

```
Primary restoral attempts =      6  completions =      5  
Restoral packets forwarded =    346  
Most recent restoral period in hrs:min:sec      00:08:20
```

### Primary Interface

The interface that is being backed up by this associated secondary interface.

### Secondary Interface

The dial circuit that is being used to back up the associated primary interface.

### Secondary Enabled

Indicates whether restoral of this primary interface is currently enabled.

### Router Primary Interface State

Indicates that the primary interface state is one of the following:

Up - Indicates that the link is up.

Down - Indicates that the link is down.

Disabled - Indicates that the operator has disabled the link.

Not present - Indicates that the link is configured but there is a hardware problem.

### Router Secondary Interface State

Indicates that the associated secondary interface state is one of the following:

Up - Indicates that the link is up.

Down - Indicates that the link is down. This also occurs when the base network for the secondary is disabled either at the Config> prompt or at the operator console.

Available - Indicates that the link is in the waiting mode.

## Configuring WAN Restoral

Testing - Indicates that the link is in the process of establishing a connection.

### Restoral Statistics:

#### Primary Restoral Attempts

The number of times the primary failed, causing the router to try to bring up a secondary link.

#### Restoral Packets forwarded

This field indicates the total number of packets forwarded.

#### Most Recent Restoral Period

This indicates how long the secondary was up, the last time it was used or during the current restoral use.

### summary

Provides totals for each secondary circuit.

#### Example:

##### list summary

WAN Restoral is enabled with 3 circuit(s) configured

```
Total restoral attempts =      3 completions =      2
Total packets forwarded =    346
Longest restoral period in hrs:min:sec  00:08:20
```

```
-----
Primary Interface and State      Secondary Interface and State
-----
1 PPP/0 - Up                    3 PPP/1 - Available
```

#### Total restoral attempts

The number of times the primary failed, causing the router to try to bring up a secondary link.

#### Completions

The number of successful restoral attempts when the secondary came up and was used.

#### Total packets forwarded

The total number of packets forwarded across the secondary interface. It is the sum of both directions, and is cumulative over all restoral periods until the restart or clear restoral-statistics command is used.

#### Longest restoral period

This field displays in hours, minutes, seconds the longest amount of time restoral was in use, not counting the current usage.

#### Primary Interface and State

The interface that is being backed up by its associated secondary. Valid states are:

Up - Indicates that the link is up.

Down - Indicates that the link is down.

Disabled - Indicates that the operator has disabled the link.

Not present - Indicates that the link is configured but there is a hardware problem.

#### Secondary Interface and State

The dial circuit that is being used to back up the associated primary. Valid states are:

Up - Indicates that the link is up.

## Configuring WAN Restoral

Down - Indicates that the link is down. This also occurs when the base network for the secondary is disabled either at the Config> prompt or at the operator console.

Testing - Indicates that the link is in the process of establishing a connection.

Available - Indicates that the link is in the waiting mode.

---

## WAN Restoral and WAN Reroute Dynamic Reconfiguration Support

This section describes dynamic reconfiguration (DR) as it affects Talk 6 and Talk 5 commands.

### CONFIG (Talk 6) Delete Interface

WAN Restoral and WAN Reroute supports the CONFIG (Talk 6) **delete interface** command with no restrictions.

### GWCON (Talk 5) Activate Interface

WAN Restoral and WAN Reroute supports the GWCON (Talk 5) **activate interface** command with the following considerations:

- You cannot activate a WAN Restoral primary interface if its secondary interface is actively restoring another primary interface.
- You cannot activate a WAN Restoral primary interface if its secondary interface was a WAN Restoral primary interface, a WAN Reroute primary interface, or a WAN Reroute alternate interface prior to the **activate interface** command.
- You cannot activate a WAN Restoral secondary interface if its primary interface is actively being restored by another secondary interface.
- You cannot activate a WAN Restoral secondary interface if its primary interface was a WAN Restoral secondary interface, a WAN Reroute primary interface, or a WAN Reroute alternate interface prior to the **activate interface** command.
- You cannot activate a WAN Reroute primary interface if its alternate interface was used as a WAN Reroute primary interface, a WAN Restoral primary interface, or a WAN Restoral alternate interface prior to the **activate interface** command.
- You cannot activate a WAN Reroute alternate interface if its primary interface was the primary interface for another alternate interface, was a WAN Reroute alternate interface, was a WAN Restoral primary interface, or a WAN Restoral secondary interface.

All WAN Restoral and WAN Reroute interface-specific commands are supported by the GWCON (Talk 5) **activate interface** command.

### GWCON (Talk 5) Reset Interface

WAN Restoral and WAN Reroute does not support the GWCON (Talk 5) **reset interface** command.

### GWCON (Talk 5) Temporary Change Commands

WAN Restoral and WAN Reroute supports the following GWCON commands that temporarily change the operational state of the device. These changes are lost whenever the device is reloaded, restarted, or you execute any dynamically reconfigurable command.

Commands
----------

## Configuring WAN Restoral

	GWCON, feature wan, disable alternate-circuit
	GWCON, feature wan, disable dial-on-overflow
	GWCON, feature wan, disable secondary-circuit
	GWCON, feature wan, disable wrs
	GWCON, feature wan, enable alternate-circuit
	GWCON, feature wan, enable dial-on-overflow
	GWCON, feature wan, enable secondary-circuit
	GWCON, feature wan, set default
	GWCON, feature wan, first-stabilization
	GWCON, feature wan, stabilization
	GWCON, feature wan, routing-stabilization
	GWCON, feature wan, start-time-of-day-revert-back
	GWCON, feature wan, stop-time-of-day-revert-back

## Configuring WAN Restoral



---

## Chapter 7. The WAN Reroute Feature

This chapter describes the WAN reroute feature. It includes the following sections:

- “WAN Reroute Overview”
- “Configuring WAN Reroute” on page 89

---

### WAN Reroute Overview

WAN Reroute lets you set up an alternate route so that if a primary link fails, the router automatically initiates a new connection to the destination through the alternate route. See “Overview for WAN Restoral, WAN Reroute, and Dial-on-Overflow” on page 63 for an explanation of WAN Restoral, and how WAN Reroute and Dial-on-overflow work together.

The WAN Reroute process involves:

1. Detecting the primary link failure
2. Switching to the alternate link
3. Detecting the primary link recovery
4. Switching back to the primary link

The alternate link can be any link on which you can configure routable protocols (for example, IP, IPX) and the datalink type of the alternate link need not match the datalink type of the primary link. For example, the alternate link can be a LAN interface, a PPP, Frame Relay, or X.25 serial interface, or a PPP or Frame Relay dial circuit. The following are examples of interface types that cannot be alternate links: SDLC serial interfaces, SRLY serial interfaces, and base nets like V.25 bis and ISDN.

**Note:** If the primary link or alternate link is a dial circuit, that dial circuit cannot be configured for dial-on-demand. Use the **set idle 0** command at the `Circuit Config>` prompt to configure the dial circuit so that it cannot perform dial-on-demand. Refer to “Configuring and Monitoring Dial Circuits” in the *Access Integration Services Software User’s Guide* for more information.

## Configuring WAN Reroute

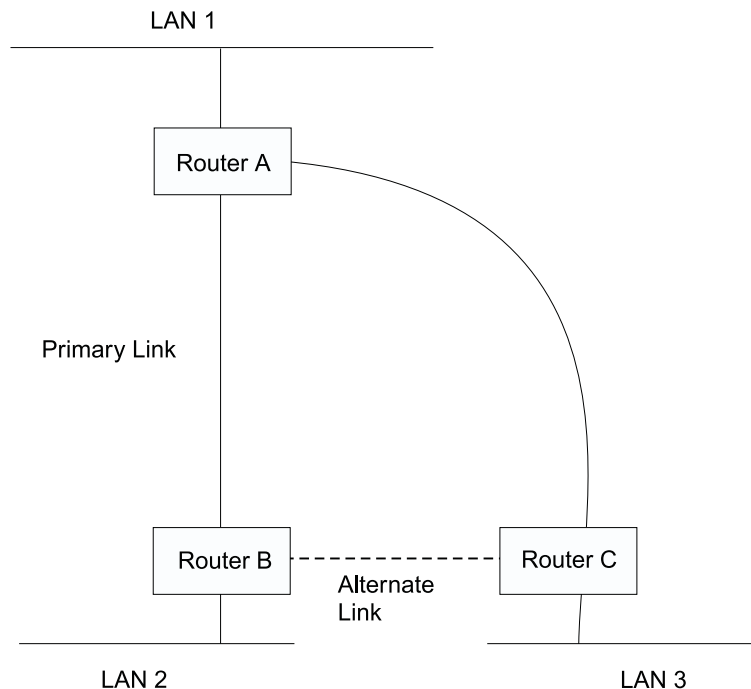

Figure 3. WAN Reroute. Normally, there is a connection between Routers A and B and Routers A and C. If the primary link between routers A and B fails, WAN reroute establishes an alternate link between routers B and C. Routers A and B can then communicate through router C.

## Dial-on-Overflow

Dial-on-overflow allows you to use an alternate interface for IP traffic when the traffic rate on the primary link reaches a specified threshold. This means that the primary interface does not have to be down before the alternate link is brought up. When the primary interface's traffic reaches the specified threshold the router brings up the alternate link. To use dial-on-overflow, WAN Reroute must be configured and the primary interface must be Frame Relay. IP is the only protocol that can be switched over to the alternate interface by dial-on-overflow. Also, OSPF should be used as the IP routing protocol instead of RIP when dial-on-overflow is used.

For information about configuring dial-on-overflow, see "WAN Restoral, WAN Reroute, and Dial-on-Overflow Configuration Commands" on page 67.

### Bandwidth Monitoring

The interval for bandwidth monitoring can be specified for dial-on-overflow during WAN Reroute configuration. The primary interface's receive and transmit bandwidth utilization are monitored. When the primary interface's bandwidth reaches the *add* threshold, a WAN Reroute request is generated to bring up the alternate interface. If WAN Reroute is successful bringing up the alternate interface, IP stops routing over the primary interface and starts routing over the alternate interface.

If WAN Reroute is not successful in bringing up the alternate route it periodically attempts to bring up the alternate interface until the primary interface's bandwidth utilization drops below the *drop* threshold.

When the primary interface's receive and transmit bandwidth utilization reaches the *drop* threshold and the minimum configured up time has expired the alternate interface is dropped. This causes IP to stop routing over the alternate interface and start using the primary interface.

The add-threshold and the drop-threshold are specified as a percentage of the configured line speed for the primary link. The configured line speed does not always match the actual speed of the link. The amount of traffic on the link in each direction is calculated separately. The threshold is exceeded if the traffic in either direction is greater than the specified percentage.

---

### Configuring WAN Reroute

Following are the steps required to configure WAN reroute. The next section shows an example of how to perform these tasks.

To configure WAN Reroute, you need to:

1. Configure the primary link.
2. Configure the alternate link.
3. Assign the alternate link to the primary link. You can also specify a stabilization period for the primary link.

You can specify a time-of-day revert-back to the primary link which will happen after the stabilization period is over (if configured). This allows the secondary to stay up until such time that the user desires and revert back to the primary during off-peak hours.

**Note:** The primary and alternate links can be different datalink types. The primary and alternate links can be:

- A LAN interface.
- A PPP serial interface.
- A Frame Relay serial interface.
- An X.25 serial interface.
- A PPP dial circuit.
- A Frame Relay dial circuit.

### Sample WAN Reroute Configuration

Figure 4 on page 90 shows WAN reroute using a Frame Relay dial circuit over ISDN as the alternate link. If the Frame Relay DLCI between router A and router C fails, WAN reroute uses the dial circuit to establish an alternate connection through router D. If one of the primary links from a branch to headquarters fails, WAN reroute establishes an alternate route to headquarters through another branch.

## Configuring WAN Reroute

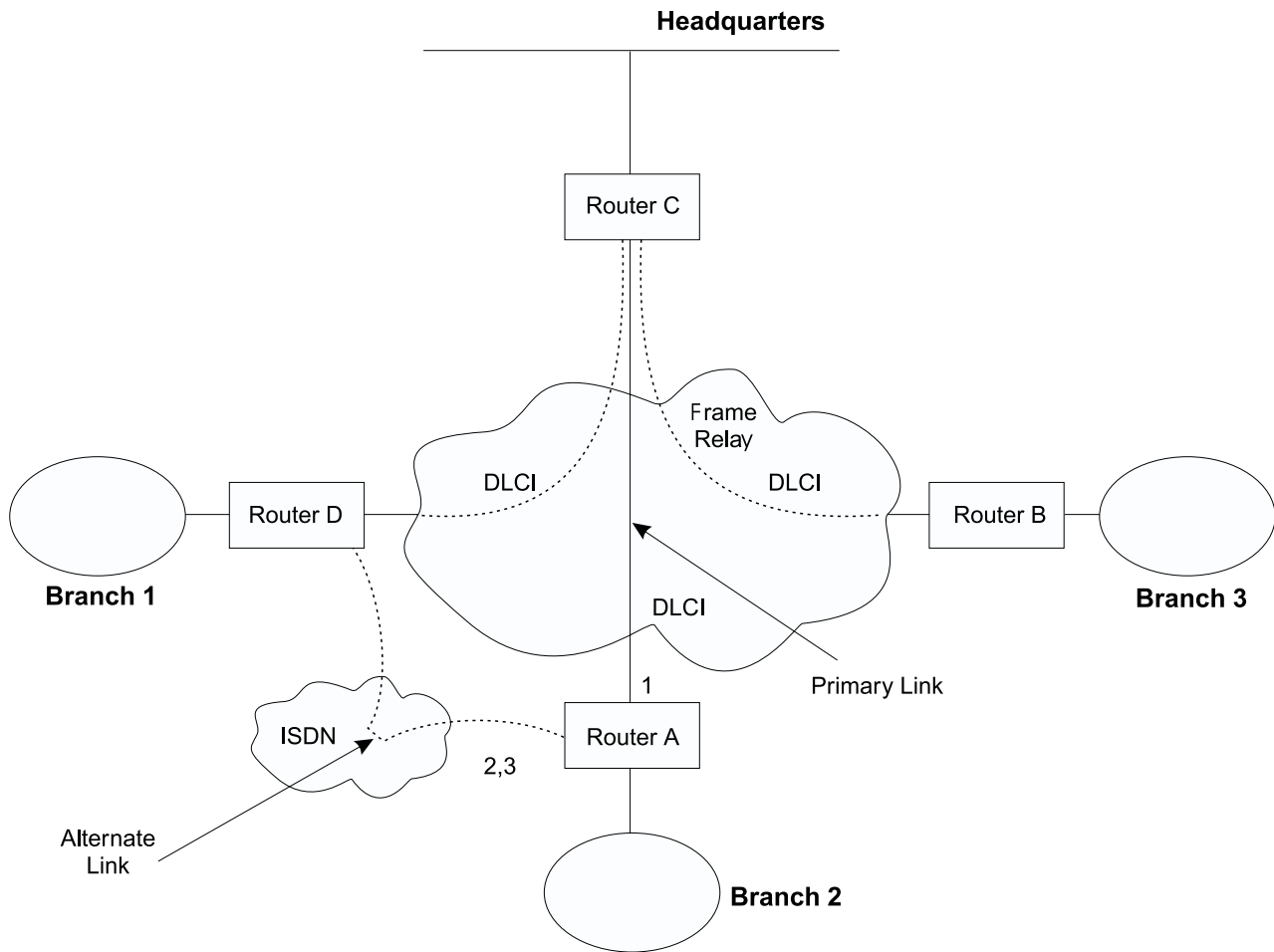

Figure 4. Sample WAN Reroute Configuration. Branch offices use frame relay to connect to headquarters.

The following sections describe how to set up WAN reroute on Router A in Figure 4. You will need to:

- Configure the primary frame relay interface (1) to have a Required PVC or Required PVC Group or enable the No-PVC feature on the frame relay interface.
- Configure the ISDN interface (2) and its frame relay dial circuit (3).
- Assign the dial circuit to be the alternate link for the primary frame relay interface and issue the **set idle 0** command at the dial Circuit Config> prompt to disable dial-on-demand for this circuit.
- Optionally, you can assign:
  - Stabilization period for the primary link,
  - Time-of-day revert-back window for the primary link.

These tasks are described in detail below.

### Configuring the Frame Relay Interface

To configure the frame relay interface for WAN reroute, on Router A, add a PVC between Routers A and C on the primary Frame Relay interface.

To cause the primary FR interface to declare itself down when the connection to other router(s) is lost, you have three options:

1. Enable the No-PVC feature. When this feature is enabled, the FR interface goes down when there are no active PVCs.

## Configuring WAN Reroute

2. Configure a PVC as required but don't include the PVC in a required PVC group. In this case, the FR interface goes down when the PVC becomes inactive.
3. Configure a set of PVCs as required and as part of a required PVC group. In this case, the FR interface goes down when all of the PVCs of a required PVC group become inactive.

Follow these steps to configure the primary Frame Relay interface:

1. If you have not yet done so, set the data link on the ISDN interface to Frame Relay.

```
Config>set data-link frame relay
Interface Number [0]? 2
```

2. Enter the Frame Relay configuration process.

```
Config>network
What is the network number [0]?2
Frame Relay user configuration
FR Config>
```

**Note:** Complete only *one* of the two remaining steps for configuring the primary frame relay interface.

3. Add a PVC using the **add permanent-virtual-circuit** command.

To configure the PVC as Required:

Enter **y** to the question "Is circuit required for interface operation ?".

To configure the PVC as a member of a required PVC group:

- a. Enter **y** to the question "Does circuit belong to a Required PVC group ?".
- b. Enter a group name in response to the question "What is the group name ?".

If you have already added PVCs, use the **change permanent-virtual-circuit** command to configure the PVC as Required and to assign it to a Required PVC Group, as appropriate. Refer to Using Frame Relay Interfaces in *Access Integration Services Software User's Guide* for more information.

```
FR Config>add permanent-virtual-circuit
Circuit number [16]?
Committed Information Rate (CIR) in bps [64000]?
Committed Burst Size (Bc) in bits [64000]?
Excess Burst Size (Be) in bits [0]?
Assign circuit name []?
Is circuit required for interface operation [N]?y
Does the circuit belong to a required PVC group [N]? y
What is the group name []?group1
```

4. If desired, enable the No-PVC feature.

**Note:** Complete this step *only* if you bypassed the previous step.

```
FR Config>enable no-pvc
```

There are additional parameters that you can set for frame relay. For more information, see 'Using Frame Relay' in *Access Integration Services Software User's Guide*.

### Configuring the ISDN Interface and Dial Circuit

Configure the ISDN interface and dial circuit between Router A and Router D. See 'Using the ISDN Interface' in *Access Integration Services Software User's Guide* for information on how to configure ISDN interfaces and dial circuits.

Unlike WAN Restoral, you must configure routable protocols on the dial circuit that will be used as the alternate link. If those routable protocols cannot be prevented

## Configuring WAN Reroute

from sending maintenance packets, the alternate link will establish a connection even if rerouting is not necessary. In this case if you want to use the alternate link only for rerouting, disable the dial circuit. To disable the dial circuit, enter the **disable interface** command at the `Config>` prompt.

If you have multiple dial circuits assigned to the ISDN interface, you can set a priority for the dial circuits. If all the B channels have active dial circuits on the physical interface and a circuit with a higher priority receives a packet, the lowest priority connection is terminated and the high priority circuit establishes a connection.

You can set the priority to between 0 and 15, where 15 is the highest priority circuit and 0 is the lowest priority circuit. The default priority for new dial circuits is 8. Enter **set priority** at the `Circuit Config>` prompt to change the priority.

### Assigning and Configuring the Alternate Link

Enter the WAN reroute configuration process to assign the dial circuit as the alternate link for a LAN interface, a PPP, Frame Relay, or X.25 serial interface, or a PPP or Frame Relay dial circuit, and if desired, to specify the stabilization periods and/or the time-of-day revert-back window.

There are three types of stabilization periods:

- *First stabilization period* is the amount of time the router waits for the primary interface to become active when the router first attempts to bring it up. If, after the first stabilization period, the primary has not come up, WAN reroute brings up the alternate link.
- *Stabilization period* is the amount of time the router waits to be sure the primary link is reliable before it switches from the alternate link back to the primary link.
- *Routing stabilization period* is the amount of time that the router keeps both the primary link and the alternate link active after it switches from the alternate link back to the primary link. This time is used by routing protocols such as OSPF or RIP to recognize the availability of the new route over the primary link before the alternate link goes down.

The time-of-day revert-back window is the specific time of day when the user desires the switch back to the primary after it is up and any configured stability time has passed.

Using a 24-hour clock, the user specifies the start and stop hours of the revert back window. The secondary stays up and is not taken down until the start hour is reached. If the time of day when the primary comes up is between the start and stop hours (in the window) then the switch to the primary link is immediate after the stability time is up.

Follow these steps to assign and configure the alternate link:

1. Enter the WAN Restoral configuration process.  

```
Config>feature wrs
WAN Restoral user configuration
```
2. Assign the dial circuit as the alternate link for the primary frame relay interface.  

```
WRS Config>add alternate-circuit
Alternate interface number [0]? 4
Primary interface number [0]? 1
```
3. Enable the alternate circuit.  

```
WRS Config>enable alternate-circuit
Alternate interface number [0]? 4
```
4. Optionally, specify a first stabilization period.

To set the first stabilization period for a specific primary interface, use the **set first-stabilization-period** command. To set a default first stabilization period for all interfaces that do not have specific periods set, use the **set default first-stabilization-period** command.

```
WRS Config>set first-stabilization-period
Primary interface number [0]?
First primary stabilization time (0 - 3600 seconds -1=default) [-1]?
```

```
WRS Config>set default first-stabilization-period
Default first primary stabilization time (0 - 3600 seconds) [0]?
```

- Optionally, specify a stabilization period. To set a stabilization period for specific interfaces use the **set stabilization-period** command. To set a default stabilization period for all interfaces that do not have specific periods set, use the **set default stabilization-period** command.

```
WRS Config>set stabilization-period
Primary interface number [0]?
First primary stabilization time (0 - 3600 seconds -1=default) [-1]?
WRS Config>set default stabilization-period
Default first primary stabilization time (0 - 3600 seconds) [0]?
```

- Optionally, specify a routing stabilization period. To set a routing stabilization period for specific interfaces use the **set routing-stabilization** command.

```
WRS Config>set routing-stabilization
Primary interface number [0]? 1
Routing stabilization time (0 - 3600 seconds) [15]?
```

- Optionally, specify a time-of-day-revert-back window.

To set the start and stop times for specific interface windows use the **set start-time-of-day-revert-back** and **set stop-time-of-day-revert-back** commands. The default value of zero means no window is configured. The 24-hour clock starts at 1 a.m. and ends at 24 midnight. If the start and stop times are the same (but not zero) then the revert back will happen at exactly that hour.

Following are two examples of setting the revert-back window:

- A start time of 23 and a stop time of 3 will give a revert-back window from 11 p.m. until 3 a.m.
- A start time of 1 and a stop time of 5 will give a revert-back window from 1 a.m. to 5 a.m.

```
WRS Config> set start-time-of-day-revert-back
Primary interface number [0]?
Time-of-Day revert back window start (1 - 24 hours, 0 = not configured) [0]?
WRS Config> set stop-time-of-day-revert-back
Primary interface number [0]?
Time-of-Day revert back window stop (1 - 24 hours, 0 = not configured) [0]?
```

## Configuring WAN Reroute



---

## Chapter 8. Using the Network Dispatcher Feature

This chapter describes how to use the Network Dispatcher Feature and contains the following sections:

- “Overview of Network Dispatcher”
- “Balancing TCP and UDP Traffic Using Network Dispatcher” on page 96
- “High Availability for Network Dispatcher” on page 97
- “Configuring Network Dispatcher” on page 99
- “Using Network Dispatcher with TN3270 Server” on page 106
- “Using Network Dispatcher with Cluster Address Advertising” on page 109
- “Using Network Dispatcher with Web Server Cache” on page 110
- “Using Network Dispatcher with eNetwork Host On-Demand Client Cache” on page 111
- “Using Network Dispatcher with Scalable High Availability Cache (SHAC)” on page 111

Network Dispatcher uses load-balancing technology from IBM to determine the most appropriate server to receive each new connection. This is the same technology used in IBM's SecureWay<sup>®</sup> Network Dispatcher product for Solaris, Windows NT<sup>®</sup> and AIX<sup>®</sup>.

---

### Overview of Network Dispatcher

Network Dispatcher is a feature that boosts the performance of servers by forwarding TCP/IP session requests to different servers within a group of servers, thus load balancing the requests among all servers. The forwarding is transparent to the users and to applications. Network Dispatcher is useful for server applications such as e-mail, World Wide Web servers, distributed parallel database queries, and other TCP/IP applications.

Network Dispatcher can also be used for load balancing stateless UDP application traffic to a group of servers.

Network Dispatcher can help maximize the potential of your site by providing a powerful, flexible, and scalable solution to peak-demand problems. During peak demand periods, Network Dispatcher can automatically find the optimal server to handle incoming requests.

The Network Dispatcher function does not use a domain name server for load balancing. It balances traffic among your servers through a unique combination of load balancing and management software. Network Dispatcher can also detect a failed server and forward traffic to other available servers.

All client requests sent to the Network Dispatcher machine are forwarded to the server that is selected by the Network Dispatcher as the optimal server according to certain dynamically set weights. These weights are calculated by Network Dispatcher based on a number of factors including connection counts, server load and server availability.

The server sends a response back to the client without any involvement of Network Dispatcher. No additional software is required on your servers to communicate with Network Dispatcher.

The Network Dispatcher function is the key to stable, efficient management of a large, scalable network of servers. With Network Dispatcher, you can link many

## Using Network Dispatcher

individual servers into what appears to be a single, virtual server. Your site thus appears as a single IP address to the world. Network Dispatcher functions independently of a domain name server; all requests are sent to the IP address of the Network Dispatcher machine.

Network Dispatcher allows a management application that is SNMP-based to monitor Network Dispatcher status by receiving basic statistics and potential alert situations. Refer to “SNMP Management” in the *Protocol Configuration and Monitoring Reference Volume 1* for more information.

Network Dispatcher brings distinct advantages in load balancing traffic to clustered servers, resulting in stable and efficient management of your site.

---

## Balancing TCP and UDP Traffic Using Network Dispatcher

There are many different approaches to load balancing. Some of these approaches allow users to choose a different server at random if the first server is slow or not responding. Another approach is round-robin, in which the domain name server selects a server to handle requests. This approach is better, but does not take into consideration the current load on the target server or even whether the target server is available.

Network Dispatcher can load balance requests to different servers based on the type of request, an analysis of the load on servers, or a configurable set of weights that you assign. To manage each different type of balancing, the Network Dispatcher has the following components:

### Executor

Load balances connections based on the type of request received. Typical request types are HTTP, FTP, and Telnet. This component always runs.

### Advisors

Queries the servers and analyzes the results by protocol for each server. The advisor passes this information to the **manager** to set the appropriate weight. The advisor is an optional component. However, if you do not use an advisor, Network Dispatcher will not be able to detect when a server has failed and will continue to send new connections to a down server.

Network Dispatcher supports advisors for FTP, HTTP, SMTP, NNTP, POP3, and Telnet as well as a TN3270 advisor that works with TN3270 servers in IBM 2210s, IBM 2212s, and IBM 2216s, and an MVS™ advisor that works with Workload Manager (WLM) on MVS systems. WLM manages the amount of workload on an individual MVS ID. Network Dispatcher can use WLM to help load balance requests to MVS servers running OS/390® V1R3 or later release.

There are no protocol advisors specifically for UDP protocols. If you have MVS servers, you can use the MVS system advisor to provide server load information. Also, if the port is handling TCP and UDP traffic, the appropriate TCP protocol advisor can be used to provide advisor input for the port. Network Dispatcher will use this input in load balancing both TCP and UDP traffic on that port.

### Manager

Sets weights for a server based on:

- Internal counters in the executor
- Feedback from the servers provided by the protocol advisors
- Feedback from a system monitor (MVS advisor).

The manager is an optional component. However, if you do not use the manager, the Network Dispatcher will balance the load using a round-robin scheduling method based on the server weights you have configured for each server.

When using Network Dispatcher to load balance stateless UDP traffic, you must only use servers that respond to the client using the destination IP address from the request. See “Configuring a Server for Network Dispatcher” on page 104 for a more complete explanation.

---

## High Availability for Network Dispatcher

The base Network Dispatcher function has the following characteristics that makes it a single point of failure from many different perspectives:

- It examines all the traffic on the way in. If some of the packets for an existing connection use a different path through a different Network Dispatcher to reach a server, the server immediately resets the connection.
- It keeps track of all established connections and although it does not terminate them, entries lost from the Network Dispatcher connection table will result in the resetting of a connection.
- It appears to any previous hop router as the last hop, and the connection’s termination.

All these characteristics make the following failures critical for the whole cluster:

- If the Network Dispatcher fails for any reason, all the connection tables are lost, therefore all existing connections from the client to the server are also lost. Assuming there is a second Network Dispatcher that can direct a client to the servers, new connections will be able to go through only after the usual routing protocol delays which could be several minutes.
- If the configured Network Dispatcher interface to the previous IP router fails, there must either be another interface to get to the same Network Dispatcher, in which case recovery is performed by the IP router (using the ARP aging mechanism with delays in the order of several minutes), or all connections will be lost.
- If Network Dispatcher interface to the servers fails, the previous hop router assumes that the Network Dispatcher is the last hop, and therefore will not reroute new connections. Existing connections will be lost and new connections will not be established.

In all these failure cases, which are not only Network Dispatcher failures but also Network Dispatcher neighborhood failures, all the existing connections are lost. Even with a backup Network Dispatcher running standard IP recovery mechanisms, recovery is, at best, slow and applies only to new connections. In the worst case, there is no recovery of the connections.

To improve Network Dispatcher availability, the Network Dispatcher High Availability function uses the following mechanisms:

- Two Network Dispatchers with connectivity to the same clients, and the same cluster of servers, as well as connectivity between the Network Dispatchers.
- A “Heartbeat” mechanism between the two Network Dispatchers to detect Network Dispatcher failure.
- A reachability criteria, to identify which IP hosts can and cannot be reached from each Network Dispatcher.

## Using Network Dispatcher

- Synchronization of the Network Dispatcher databases (that is, the connection tables, reachability tables, and other databases).
- Logic to elect the active Network Dispatcher, which is in charge of a given cluster of servers, and the standby Network Dispatcher, which continuously gets synchronized for that cluster of servers.
- A mechanism to perform fast IP takeover, when the logic or an operator decides to switch active and standby.

## Failure Detection

Besides the basic criteria of failure detection, (the loss of connectivity between active and standby Network Dispatchers, detected through the Heartbeat messages) there is another failure detection mechanism named “reachability criteria.” When you configure the Network Dispatcher, you provide a list of hosts that each of the Network Dispatchers should be able to reach to work correctly. The hosts could be routers, IP servers or other types of hosts. Host reachability is obtained by pinging the host.

Switchover takes place either if the Heartbeat messages cannot go through, or if the reachability criteria are no longer met by the active Network Dispatcher and the standby Network Dispatcher is reachable. To make the decision based on all available information, the active Network Dispatcher regularly sends the standby Network Dispatcher its reachability capabilities. The standby Network Dispatcher then compares the capabilities with its own and decides whether to switch.

## Database Synchronization

The primary and backup Network Dispatchers keep their databases synchronized through the “Heartbeat” mechanism. The Network Dispatcher database includes connection tables, reachability tables and other information. The Network Dispatcher High Availability function uses a database synchronization protocol that insures that both Network Dispatchers contain the same connection table entries. This synchronization takes into account a known error margin for transmission delays. The protocol performs an initial synchronization of databases and then maintains database synchronization through periodic updates.

## Recovery Strategy

In the case of a Network Dispatcher machine or interface failure, the IP takeover mechanism will promptly direct all traffic toward the standby Network Dispatcher. The Database Synchronization mechanism insures that the standby has the same entries as the active Network Dispatcher, so existing client-server connections are maintained.

## IP Takeover

**Note:** Cluster IP Addresses are assumed to be on the same logical subnet as the previous hop router (IP router) as the previous hop router (IP router) unless you are using cluster address advertising.

The IP Router will resolve the cluster address through the ARP protocol. To perform the IP takeover, the Network Dispatcher (standby becoming active) will issue an ARP request to itself, that is broadcasted to all directly attached networks belonging to the logical subnet of the cluster. The previous hops’ IP router will update their ARP tables (according to RFC826) to send all traffic for that cluster to the new active (previously standby) Network Dispatcher.

## Configuring Network Dispatcher

There are many ways that you can configure Network Dispatcher to support your site. If you have only one host name for your site to which all of your customers will connect, you can define a single cluster and any ports to which you want to receive connections. This configuration is shown in Figure 5.

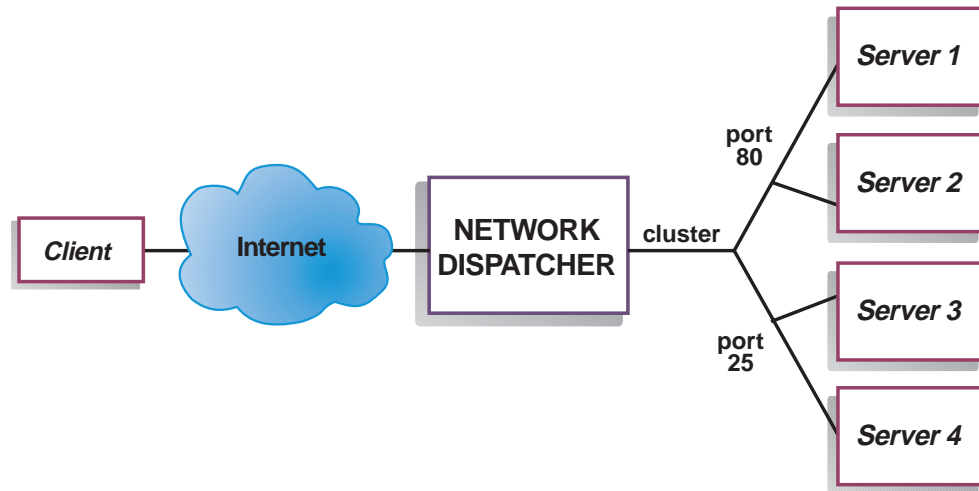

Figure 5. Example of Network Dispatcher Configured With a Single Cluster and 2 Ports

Another way of configuring Network Dispatcher would be necessary if your site does content hosting for several companies or departments, each one coming into your site with a different URL. In this case, you might want to define a cluster for each company or department and any ports to which you want to receive connections at that URL as shown in Figure 6 on page 100.

## Using Network Dispatcher

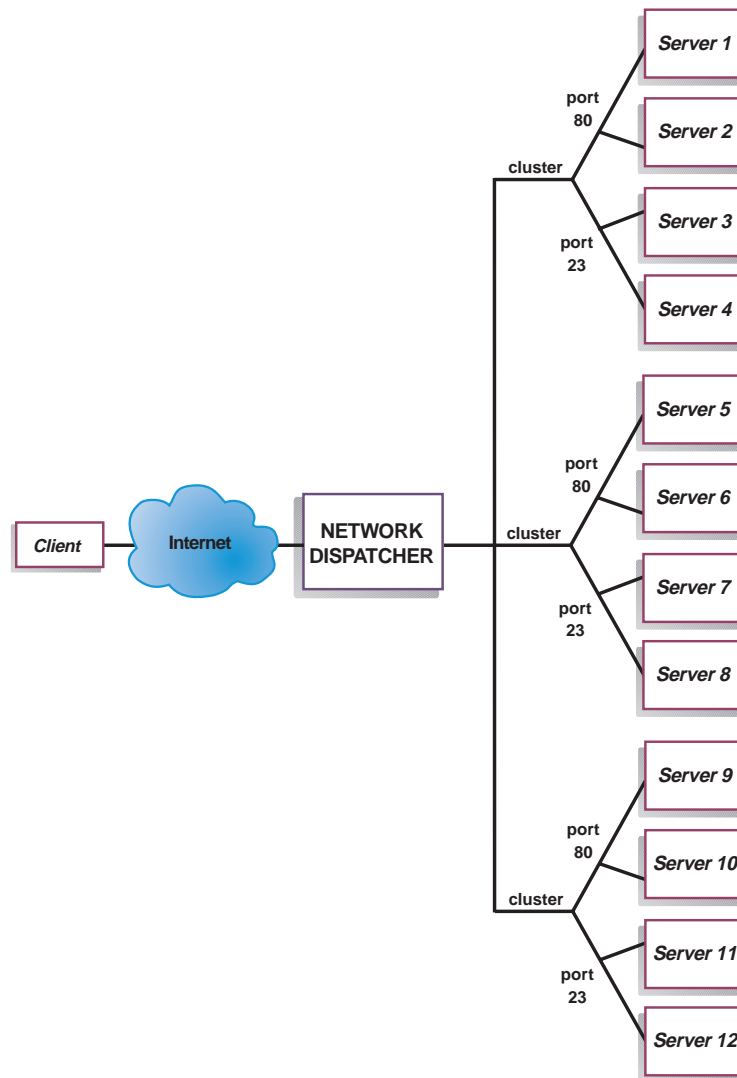

Figure 6. Example of Network Dispatcher Configured With 3 Clusters and 3 URLs

A third way of configuring Network Dispatcher would be appropriate if you have a very large site with many servers dedicated to each protocol supported. For example, you may choose to have separate FTP servers with direct T3 lines for large downloadable files. In this case, you might want to define a cluster for each protocol with a single port but many servers as shown in Figure 7 on page 101.

## Using Network Dispatcher

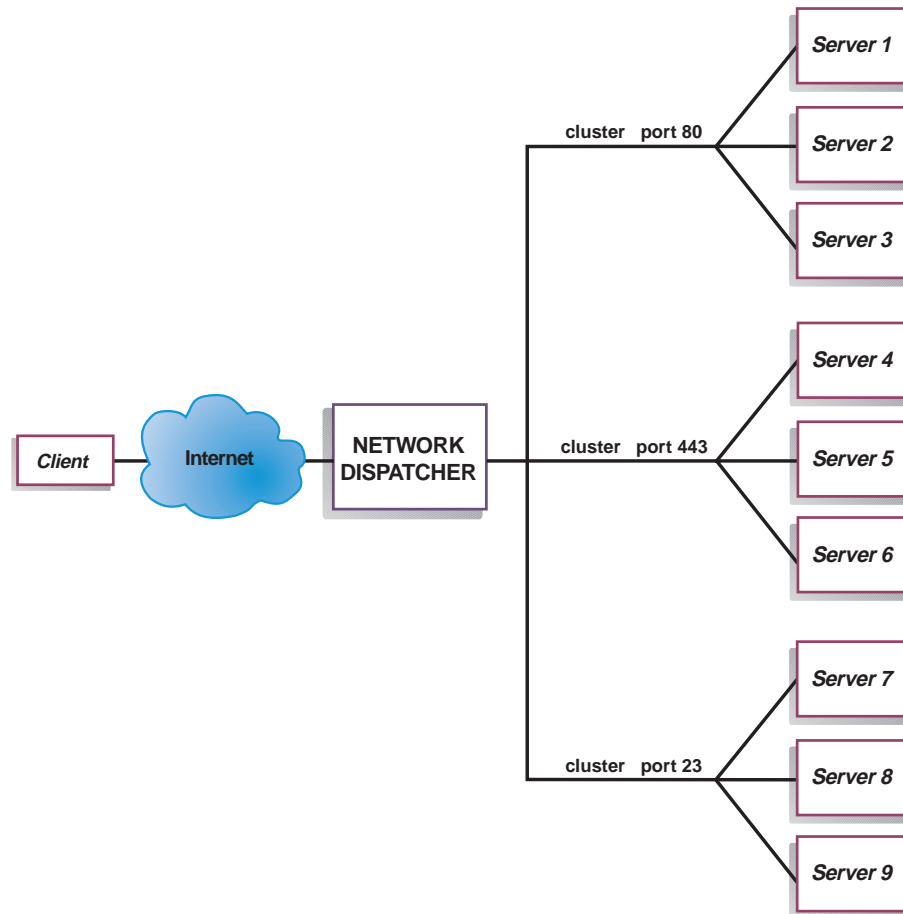

Figure 7. Example of Network Dispatcher Configured with 3 Clusters and 3 Ports

## Configuration Steps

Before configuring Network Dispatcher:

1. Make sure that the Network Dispatcher has direct interfaces to servers (i.e. each server machine must be directly connected to a subnet that is local to the Network Dispatcher machine). Since the Network Dispatcher feature only sees traffic flowing from client to server, servers can have independent connections to the enterprise router or Internet, so that the outgoing traffic from servers to clients can bypass the Network Dispatcher machine. There is no special Network Dispatcher configuration required to allow these types of outgoing connections.

If high availability is important for your network, a typical high availability configuration is shown in Figure 8 on page 102.

## Using Network Dispatcher

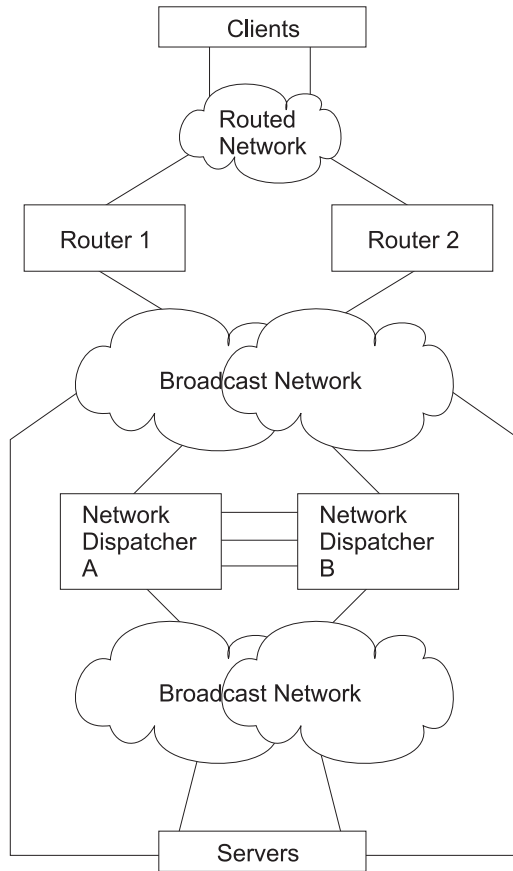

Figure 8. High Availability Network Dispatcher Configuration

2. Configure the interfaces of the Network Dispatcher machine. This includes configuring all interfaces, IP addresses on all interfaces, and any applicable routing protocols. The internal IP address of the router is used by Network Dispatcher, so it must also be configured using the `set internal-ip-address` command. The internal IP address must not match a cluster address configured in Network Dispatcher. See the chapter *Configuring and Monitoring IP in Protocol Configuration and Monitoring Reference Volume 1* for more information about the `set internal-ip-address` command.
3. Reboot or restart the Network Dispatcher machine.

### Configuring Network Dispatcher on an IBM 2212

To configure Network Dispatcher on an IBM 2212:

1. In `talk 6`, access the Network Dispatcher feature, using the `feature ndr` command.
2. Enable the executor and the manager using the `enable executor` and `enable manager` commands.
3. Configure the clusters using the `add cluster` command. If you configure your cluster addresses to be advertised, see “Using Network Dispatcher with Cluster Address Advertising” on page 109 for more information. If you choose not to have Network Dispatcher advertise your cluster addresses, you should select cluster addresses that are part of an advertised subnet that is local to the Network Dispatcher router. This would typically be the subnet on which Network Dispatcher receives client traffic from the next hop router.



**Note:** Cluster IP Addresses must not match the internal IP address of the router and must not match any interface IP addresses defined on the router. If you are running Network Dispatcher and TN3270 server in the same machine, the cluster address can match an IP address defined on the loopback interface. See “Using Network Dispatcher with TN3270 Server” on page 106 for more information.

4. Configure the TCP and UDP destination ports using the **add port** command for each cluster of servers that will serve the corresponding protocol. Examples of typical ports are: 80 for HTTP, 20 and 21 for FTP, and 23 for Telnet.
5. Configure the servers using the **add server** commands. A server is always associated with a port and a cluster. A server can serve more than one port (that is, a server can be defined under multiple ports for the same cluster), and a server can belong to more than one cluster, if the server’s operating system supports multiple aliasing.
6. Configure any advisors using the **add advisor** command.

**Notes:**

- a. For the MVS advisor, do not define the Port Number value (default = 10007) under any cluster. This port number is used only by the MVS advisor to communicate with WLM in the MVS systems.
  - b. For the TN3270 advisor, two port values are entered. The port number value used for client-server communication (default = 23) must be defined under the appropriate clusters. Do not define the communication port value (default = 10008) under any cluster. The Communication Port value is used only by the TN3270 advisor to collect load information from the TN3270 servers.
7. Enable the advisors that you configured using the **enable advisor** command and set the manager proportions to include advisor input in the weight calculations using the **set manager** command.

If you are configuring the Network Dispatcher for high availability, continue with the following steps. Otherwise, you have completed the configuration.

**Note:** Perform these steps on the primary Network Dispatcher and then on the backup. To ensure proper database synchronization, the executor in the primary Network Dispatcher must be enabled before the executor in the backup.

8. Configure whether this Network Dispatcher is a primary or backup and whether the switchover is manual or automatic using the **add backup** command.
9. Configure all paths on which the heartbeat is going to take place between the primary and backup Network Dispatchers using the **add heartbeat** command. A path is specified by source and destination IP addresses.

**Note:** Configuring more than one heartbeat path between the primary and backup Network Dispatchers is required to ensure that the failure of a single interface will not disrupt the heartbeat communication between the primary and backup machines.

If you have only one existing LAN connection between the two Network Dispatchers, the second heartbeat could be set up over a simple LAN connection (for example, a crossover cable used directly between two Ethernet ports) or a point-to-point serial connection (for example, back-to-back PPP connection over a null-modem cable using unnumbered IP).

## Using Network Dispatcher

10. Configure the list of host IP addresses that the Network Dispatcher must be able to reach in order to insure a full service, using the **add reach** command. Typically, this will be a subset of servers, the enterprise router, or an administration station. At least one reach address should be configured for each interface on which Network Dispatcher traffic may flow.

You can change the configuration using the **set**, **remove**, and **disable** commands. See “Chapter 9. Configuring and Monitoring the Network Dispatcher Feature” on page 113 for more information about these commands.

### Configuring a Server for Network Dispatcher

To configure a server for use with Network Dispatcher:

1. Alias the loopback device.

For the TCP and UDP servers to work, you must set (or preferably alias) the loopback device (usually called **lo0**) to the cluster address. Network Dispatcher does not change the destination IP address in the IP packet before forwarding the packet to a server machine. When you set or alias the loopback device to the cluster address, the server machine will accept a packet that was addressed to the cluster address.

It is important that the server use the cluster address rather than its own IP address to respond to the client. This is not a concern with TCP servers, but some UDP servers use their own IP address when they respond to requests that were sent to the cluster address. When the server uses its own IP address, some clients will discard the server's response because it is not from an expected source IP address. You should use only UDP servers that use the destination IP address from the request when they respond to the client. In this case, the destination IP address from the request is the cluster address.

If you have an operating system that supports network interface aliasing such as AIX, Solaris, or Windows NT, you should alias the loopback device to the cluster address. The benefit of using an operating system that supports aliases is that you can configure the server machines to serve multiple cluster addresses.

If you have a server with an operating system that does not support aliases, such as HP-UX and OS/2, you must set **lo0** to the cluster address.

If your server is an MVS system running TCP/IP V3R2, you must set the VIPA address to the cluster address. This will function as a loopback address. The VIPA address must not belong to a subnet that is directly connected to the MVS node. If your MVS system is running TCP/IP V3R3, you must set the loopback device to the cluster address. If you are using high availability, you must enable Routed in the MVS system so that the high availability takeover mechanism will function properly.

**Note:** The commands listed in this chapter were tested on the following operating systems and levels: AIX 4.2.1 and 4.3, HP-UX 10.2.0, Linux, OS/2 Warp Connect Version 3.0, OS/2 Warp Version 4.0, Solaris 2.6 (Sun OS 5.6), Windows NT 3.51 and 4.0, and OS/390.

Use the command for your operating system as shown in Table 10 to set or alias the loopback device.

Table 10. Commands to alias the loopback device (lo0) for Dispatcher

System	Command
AIX	<b>ifconfig lo0 alias cluster_address netmask netmask</b>
HP-UX	<b>ifconfig lo0 cluster_address</b>
Linux	<b>ifconfig lo:1 cluster_address netmask netmask up</b>

Table 10. Commands to alias the loopback device (lo0) for Dispatcher (continued)

System	Command
OS/2	<b>ifconfig lo cluster_address</b>
Solaris	<b>ifconfig lo0:1 cluster_address 127.0.0.1 up</b>
Windows NT	<ol style="list-style-type: none"> <li>Click <b>Start</b>, then click <b>Settings</b>.</li> <li>Click <b>Control Panel</b>, then double-click <b>Network</b>.</li> <li>If you have not done so already, add the MS Loopback Adapter Driver. <ol style="list-style-type: none"> <li>In the Network window, click <b>Adapters</b>.</li> <li>Select <b>MS Loopback Adapter</b>, then click <b>OK</b>.</li> <li>When prompted, insert your installation CD or disks.</li> <li>In the Network window, click <b>Protocols</b>.</li> <li>Select <b>TCP/IP Protocol</b>, then click <b>Properties</b>.</li> <li>Select <b>MS Loopback Adapter</b>, then click <b>OK</b>.</li> </ol> </li> <li>Set the loopback address to your cluster address. Accept the default subnet mask (255.0.0.0) and do not enter a gateway address. <p><b>Note:</b> You may have to exit and reenter Network Settings before the MS Loopback Driver shows up under TCP/IP Configuration.</p> </li> </ol>
OS/390	<p>Configuring a loopback alias on the OS/390 system.</p> <ul style="list-style-type: none"> <li>In the IP parameter member (file), an Administrator will need to create an entry in the Home address list. For example: <pre>HOME ;Address                Link 192.168.252.11          tr0 192.168.100.100         ltr1 192.168.252.12          loopback</pre> </li> <li>Several addresses can be defined for the loopback</li> <li>The 127.0.0.1 is configured by default.</li> </ul>

## 2. Check for an extra route.

On some operating systems a default route may have been created and needs to be removed.

- Check for an extra route on Windows NT with the following command: **route print**
- Check for an extra route on all UNIX<sup>®</sup> systems and OS/2<sup>®</sup> with the following command: **netstat -nr**
- Windows NT Example: After route print is entered, a table similar to the following will be displayed. (This example shows finding and removing an extra route to cluster 9.67.133.158 with a default netmask of 255.0.0.0.)

Active Routes:

Network	Address	Netmask	Gateway Address	Interface	Metric
	0.0.0.0	0.0.0.0	9.67.128.1	9.67.133.67	1
	9.0.0.0	255.0.0.0	9.67.133.158	9.67.133.158	1
	9.67.128.0	255.255.248.0	9.67.133.67	9.67.133.67	1
	9.67.133.67	255.255.255.255	127.0.0.1	127.0.0.1	1
	9.67.133.158	255.255.255.255	127.0.0.1	127.0.0.1	1
	9.255.255.255	255.255.255.255	9.67.133.67	9.67.133.67	1
	127.0.0.0	255.0.0.0	127.0.0.1	127.0.0.1	1
	224.0.0.0	224.0.0.0	9.67.133.158	9.67.133.158	1
	224.0.0.0	224.0.0.0	9.67.133.67	9.67.133.67	1
	255.255.255.255	255.255.255.255	9.67.133.67	9.67.133.67	1

- Find your cluster address under the "Gateway Address" column. If you have an extra route, the cluster address will appear twice. In the example given, the cluster address (9.67.133.158) appears in row 2 and row 8.
- Find the network address in each row in which the cluster address appears. You need one of these routes and will need to delete the other route, which is extraneous. The extra route to be deleted will be the one whose network

## Using Network Dispatcher

address begins with the first digit of the cluster address, followed by three zeroes. In the example shown, the extra route is the one in row two, which has a network address of 9.0.0.0:

```
9.0.0.0      255.0.0.0    9.67.133.158  9.67.133.158  1
```

3. Delete any extra routes.

Use the command from Table 11 for your operating system to delete any extra routes.

Table 11. Commands to Delete Routes for Various Operating Systems

Operating System	Command
AIX	<b>route delete -net</b> <i>network_address cluster_address</i>
HP-UNIX	<b>route delete</b> <i>cluster_address cluster_address</i>
Solaris	No need to delete route.
OS/2	No need to delete route.
Windows NT	<b>route delete</b> <i>network_address cluster_address</i> <b>Notes:</b> <ol style="list-style-type: none"><li>This command should be entered at an MS-DOS prompt.</li><li>For Windows NT, you must delete the extra route every time you reboot the server.</li><li>To keep from having to manually remove the extra route each time you reboot the server, you may want to create and install a Service using the Windows NT Resource Kit that will automatically delete the extra route after each server reboot.</li></ol>

## Using Network Dispatcher with TN3270 Server

Network Dispatcher can be used with a cluster of 2210s, 2212s, Network Utilities or 2216s running TN3270E server function to provide TN3270E server support for large 3270 environments. The TN3270 advisor allows the Network Dispatcher to collect load statistics from each TN3270E server in real time to achieve the best possible distribution among the TN3270E servers. In addition to the TN3270E servers external to the Network Dispatcher router, one of the TN3270E servers in the cluster can be internal - it can run in the same router as Network Dispatcher.

## Keys to Configuration

Configuration of external TN3270E servers (i.e. TN3270E server is not running in the same router as Network Dispatcher) is essentially the same as setting up a standalone TN3270E server. In fact, the TN3270E server is unaware that the traffic from the clients is being dispatched through another machine. However, there are some points to keep in mind when setting up external TN3270E servers for use with Network Dispatcher:

- When setting up TN3270E servers, the TN3270E server IP address must also be configured on the server machine as an interface address. Clients send packets to the TN3270E server IP address and the server machine accepts the packets for delivery to a local function, in this case the TN3270E server function. With Network Dispatcher in front of the TN3270E servers, clients send packets to the Network Dispatcher cluster IP address and Network Dispatcher forwards packets to the servers without changing them, so packets arrive at the server machines with the destination IP address equal to the cluster IP address. Therefore, the TN3270 server IP address in each server must be set equal to the cluster IP address and the cluster IP address must also be defined on each server machine

as an interface address (any IP enabled interface will do) so the packets will be accepted by the server machine for local delivery to the TN3270E server function.

- You must ensure that any routing protocols being used on the TN3270E servers (e.g. OSPF or RIP) will not advertise the cluster address. The Network Dispatcher router must “own” the cluster address as far as the client network is concerned.
- If the client-to-Network Dispatcher traffic flows on the same LAN as the Network Dispatcher-to-server traffic, you must make sure the servers do not respond to ARP for the cluster address, so the cluster address cannot be defined on the server’s interface to this LAN. Network Dispatcher must be the only one responding to ARP on the LAN (or LANs) on which it receives client traffic from the network. The cluster address can alternatively be configured on the TN3270E server as an interface address on another interface or it can be configured as the internal IP address of the TN3270E server.
- Each TN3270E server must be configured in Network Dispatcher with a unique server IP address. This is the address Network Dispatcher uses to find the server. This address must also be configured as an interface address on the router performing the TN3270E server function. If the unique server IP address is not part of the subnet that is local to the Network Dispatcher machine, then Network Dispatcher must be able to find the server through either a static route defined in the Network Dispatcher machine or through routing protocols that advertise the server’s unique IP address.
- In order to keep TN3270 connections from being prematurely removed from the Network Dispatcher connection table when a period of inactivity exceeds the stale-timeout for the cluster, you should configure the TN3270E server keepalive timer in timing mark mode with a timeout value less than the stale-timeout for the cluster. TN3270E server sends a message to the client and expects a response which will keep the connection from becoming stale.

When the TN3270E server is in the same router as Network Dispatcher, the following applies:

- Since packets load balanced to an internal TN3270E server will still have the cluster address as the destination IP address of the packet, the TN3270E server IP address must be configured as the cluster address.
- When the TN3270E server is external to the Network Dispatcher machine, the TN3270E server IP address must be defined on the server as the internal IP address or as an interface address so that the packet can be locally delivered to the TN3270E server function. However, when the TN3270E server is internal to the Network Dispatcher router, the TN3270E server IP address must not be defined on the router as the internal IP address or as an interface address. If the TN3270E server IP address (i.e. the cluster address) is defined as the internal IP address or as an interface address, the packets will never get to Network Dispatcher but will go directly to the TN3270E server function in the router.
- Each TN3270E server must be configured in Network Dispatcher with a unique server IP address. For an internal TN3270E server, configure the server’s unique IP address equal to the internal IP address of the Network Dispatcher machine.
- Prior to V3.4, a TN3270E server could be set up for either internal or external access by Network Dispatcher, but it could not be both internal and external and it could not switch back and forth. As a result, when implementing a Network Dispatcher high availability solution with internal TN3270E servers in both Network Dispatcher routers, the Network Dispatcher in one router could not load balance to the TN3270E server in the other Network Dispatcher router.

## Using Network Dispatcher

Starting with AIS V3.4, when implementing a Network Dispatcher high availability solution with internal TN3270E servers in both Network Dispatcher routers, the internal TN3270E servers can be set up to be accessed by either Network Dispatcher. You simply add a loopback device on both Network Dispatcher routers and define the TN3270E server IP address (i.e. the cluster address) on each loopback interface. When Network Dispatcher is in active state, the cluster address on the loopback interface will be disabled so packets destined for the cluster address will get to Network Dispatcher. When Network Dispatcher is in standby state, the cluster address on the loopback interface will be enabled so packets destined for the cluster address will be locally delivered to the TN3270E server. In this way, an internal TN3270E server can be used by both Network Dispatchers in a high availability setup.

The active Network Dispatcher machine must be the only machine responding to ARP for the cluster address. Since the cluster address is defined on both Network Dispatcher machines on the loopback interface, proxy ARP must be disabled in both Network Dispatcher machines to keep the standby Network Dispatcher machine from responding to ARP for the cluster address.

The active Network Dispatcher machine must also own the cluster address as far as the client network is concerned, so the standby Network Dispatcher machine (which has the cluster address defined on the loopback interface) cannot advertise the cluster address. RIP by default will not advertise host routes (routes with mask 255.255.255.255), but if advertising of host routes is enabled, you must define RIP policy to specifically disable advertising of the cluster address.

This example shows the policy to prevent RIP from advertising a cluster IP address (here assumed to be 10.0.0.1). Note that the second policy entry allows RIP to advertise all other routes.

```
IP config> add route-policy
Route Policy Identifier [1-15 characters] []? rip-send
Use strictly linear policy? [No]: yes
IP config>change route-policy rip-send
rip-send IP Route Policy Configuration
IP Route Policy Config>add entry
Route Policy Index [1-65535] [0]? 1
IP Address [0.0.0.0]? 10.0.0.1
IP Mask [0.0.0.0]? 255.255.255.255
Address Match (Range/Exact) [Range]? exact
Policy type (Inclusive/Exclusive) [Inclusive]? exclusive
IP Route Policy Config>add entry
Route Policy Index [1-65535] [0]? 2
IP Address [0.0.0.0]?
IP Mask [0.0.0.0]?
Address Match (Range/Exact) [Range]?
Policy type (Inclusive/Exclusive) [Inclusive]?
IP Route Policy Config> list

IP Address      IP Mask          Match  Index  Type
-----
10.0.0.1        255.255.255.255  Exact  1      Exclude
0.0.0.0         0.0.0.0          Range  2      Include
IP Route Policy Config> exit
IP config>enable sending policy global rip-send
IP config>
```

For OSPF, if AS Boundary Routing and importing of direct routes are enabled, or OSPF is enabled on the loopback interface, the cluster address defined on the loopback interface will be advertised and you must define OSPF policy to specifically disable advertising of the cluster address.

The following example shows a policy to prevent OSPF from importing a cluster IP address (here assumed to be 10.0.0.1). Note that the second policy entry allows OSPF to import all other direct routes.

```

IP> add route-policy ospf-send
Use strictly linear policy? [No]: yes
IP config> change route-policy ospf-send
ospf-send IP Route Policy Configuration
IP Route Policy Config> add entry
Route Policy Index [1-65535] [0]? 1
IP Address [0.0.0.0]? 10.0.0.1
IP Mask [0.0.0.0]? 255.255.255.255
Address Match (Range/Exact) [Range]? exact
Policy type (Inclusive/Exclusive) [Inclusive]? exclusive
IP Route Policy Config> add entry
Route Policy Index [1-65535] [0]? 2
IP Address [0.0.0.0]?
IP Mask [0.0.0.0]?
Address Match (Range/Exact) [Range]?
Policy type (Inclusive/Exclusive) [Inclusive]?
IP Route Policy Config> add match-condition protocol direct
Route Policy Index [1-65535] [0]? 2
Route policy entry match condition updated or added
IP Route Policy Config> list

IP Address      IP Mask          Match  Index  Type
-----
10.0.0.1        255.255.255.255  Exact  1      Exclude
0.0.0.0         0.0.0.0          Range  2      Include
  Match Conditions: Protocol: Direct
IP Route Policy Config> exit
IP config> exit
Config> protocol ospf
Open SPF-Based Routing Protocol configuration console
OSPF Config> enable as
Use route policy? [No]: yes
Route Policy Identifier [1-15 characters] []? ospf-send
Always originate default route? [No]:
Originate default if BGP routes available? [No]:
OSPF Config>

```

## Explicit LUs and Network Dispatcher

Special care has to be taken for explicit LU definition in a Network Dispatcher environment. A session request for either a implicit or a explicit LU can be dispatched to any server. This means that the explicit LU has to be defined in each server, since it is not known in advance to which server the session will be dispatched.

---

## Using Network Dispatcher with Cluster Address Advertising

Cluster address advertising will allow you to configure whether or not each cluster address defined in Network Dispatcher should be advertised by the routing protocols enabled in the Network Dispatcher machine. For cluster addresses that are not advertised, you must select cluster addresses that are part of an advertised subnet that is local to the Network Dispatcher machine. Cluster addresses that are configured to be advertised will be advertised as host routes and do not have to be part of an advertised subnet. Advertising of cluster addresses is beneficial in the following scenarios:

- You may have multiple server sites geographically disbursed that provide the same content and want clients to connect to the closest active server site. You can accomplish this with cluster address advertising by configuring the same cluster addresses at all of your server sites and by advertising those cluster

## Using Network Dispatcher

addresses from all of the sites. The routing protocols in the network will then direct each client connection to the closest server site. If the closest site is down, the connection goes to the next closest server site. Keep in mind that changes in the network (a router or communication link goes down or comes back up) or changes in the availability of a server site can change which server site is closest, even in the middle of existing client-server connections. This is not a concern with short lived connections like HTTP, but it might be considered more of a concern for long lived connections like Telnet or TN3270.

- Cluster address advertising allows you to use Network Dispatcher high availability on a classical IP ATM network. When the standby Network Dispatcher takes over from the active Network Dispatcher, it sends a gratuitous ARP on all interfaces to cause future traffic destined for the cluster address to be sent to a new MAC address. With classical IP ATM, the ARP server is updated, but the ARP server cannot force clients to refresh their caches. The client caches won't get updated until the refresh timeout configured in the client expires. This could be multiple minutes. New connections from clients that had not cached the ATM address of the primary Network Dispatcher would immediately get to the backup Network Dispatcher, but connections existing at the time of the takeover would be lost and could not be reestablished until the client refresh timer for that client expires and the client's cache is updated. By defining cluster addresses that are not part of the ATM subnet with the router and by advertising those cluster addresses, the routing protocols would then cause traffic destined for the cluster addresses to be routed to the proper Network Dispatcher. The primary Network Dispatcher would stop advertising cluster addresses when it goes to standby state and the backup would start advertising cluster addresses when it becomes the active Network Dispatcher.

The routing protocols in the Network Dispatcher machine must be properly configured before they will advertise the cluster addresses:

- For RIP, you must enable sending host-routes.
- For OSPF, you must enable AS boundary routing and import both direct and subnet routes.
- For BGP, you must make sure the range of addresses in your originate policy includes the advertised cluster addresses and you must enable classless-bgp.

---

## Using Network Dispatcher with Web Server Cache

You must use Network Dispatcher to define a cluster and port for Web Server Cache. When you define a port with a mode of *cache*, you will be prompted to configure the cache partition. See the **add port** command in "Chapter 12. Configuring and Monitoring Web Server Cache" on page 197 for an example. Cache partition configuration values can later be altered using the **f webc** command at the `Config>` prompt to go directly to Web Server Cache feature configuration. See "Chapter 11. Using Web Server Cache" on page 159 and "Chapter 12. Configuring and Monitoring Web Server Cache" on page 197 for more information about Web Server Caching.

**Note:** Web Server Cache is only supported on IBM 2212s that have the High Performance System Card (HPSC).



---

## Using Network Dispatcher with eNetwork Host On-Demand Client Cache

You must use Network Dispatcher to define a cluster and port for Host On-Demand Client Cache. When you define a port with a mode of *hod client cache*, you will be prompted to configure the cache partition. See the **add port** command in “Configuring the Host On-Demand Client Cache” on page 144 for an example. Cache partition configuration values can later be altered using the **f hod** command at the `Config>` prompt to go directly to Host On-Demand Client Cache feature configuration. See “Chapter 10. Configuring and Monitoring IBM eNetwork Host On-Demand Client Cache” on page 143 for more information about Host On-Demand Client Cache.

**Note:** eNetwork Host On-Demand Client Cache is only supported on IBM 2212s that have the High Performance System Card (HPSC).

---

## Using Network Dispatcher with Scalable High Availability Cache (SHAC)

You can use Network Dispatcher with a group of Web Server Caches to create a Scalable High Availability Cache. A Scalable High Availability Cache (SHAC) consists of one or two Network Dispatcher machines (the second would be used to provide a backup for the first), two or more Web Server Cache machines, and at least one back end server. Figure 9 on page 112 shows an example of an SHAC setup. The Network Dispatcher machine load balances client traffic to the cache machines and the cache machines serve the files from the cache or get the files from the back end servers if the files have not been cached.

Network Dispatcher must be used in a Web Server Cache machine (see “Using Network Dispatcher with Web Server Cache” on page 110), so Network Dispatcher is actually running in the Network Dispatcher machine and in all of the cache machines.

In the Network Dispatcher machine, you must configure the cluster and the port, and the mode of the port must be set to *extcache* to indicate that it is load balancing an external scalable cache array. See the **add port** command on “Add” on page 113. Under the port, the cache machines are configured as servers. As with other servers, the interface IP addresses of the caches are used for the unique server IP addresses configured in the Network Dispatcher machine. The advisor and manager are critical to SHAC. The HTTP advisor must be enabled in the Network Dispatcher machine on any ports for which there are external caches (i.e. the port mode is *extcache*). The advisor queries are used to determine whether the caches are operational. The manager must be enabled and the manager proportions must be set to include advisor input in the weight calculations (i.e. set the advisor percentage to a value greater than 0).

When you configure a cache as a server under a cluster/port on the Network Dispatcher machine, you must also configure the same cluster and port in the Network Dispatcher function on the cache machine. The ports defined in the cache machines must be set to mode *cache* and the backend servers are defined as servers under these ports. The HTTP advisor should also be run in the cache machines so they will be able to determine backend server load and availability.

## Using Network Dispatcher

Note that one Network Dispatcher machine can load balance more than one SHAC cluster. See “Scalable High Availability Cache” on page 164 for additional information.

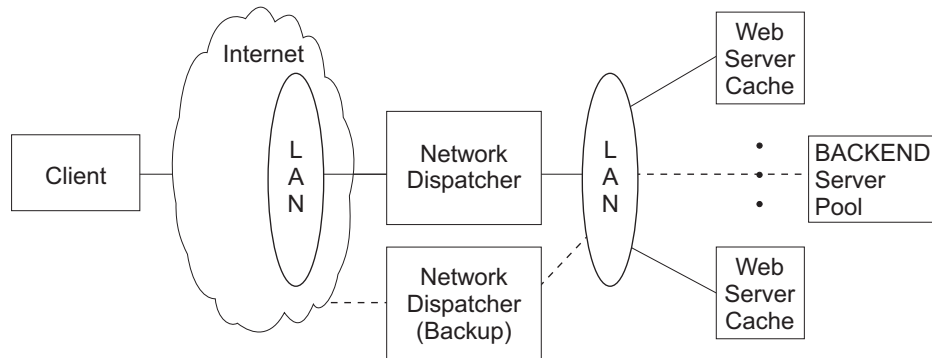

Figure 9. Lan Connected Servers

---

## Chapter 9. Configuring and Monitoring the Network Dispatcher Feature

This chapter describes the Network Dispatcher Feature configuration and operational commands. It contains the following sections:

- “Accessing the Network Dispatcher Configuration Commands”
- “Network Dispatcher Configuration Commands”
- “Accessing the Network Dispatcher Monitoring Commands” on page 131
- “Network Dispatcher Monitoring Commands” on page 132
- “Network Dispatcher Dynamic Reconfiguration Support” on page 140

---

### Accessing the Network Dispatcher Configuration Commands

To access the Network Dispatcher configuration environment:

1. Enter **talk 6** at the OPCON prompt (\*).
2. Enter **feature ndr** at the Config > prompt.

---

### Network Dispatcher Configuration Commands

Table 12 summarizes the Network Dispatcher configuration commands and the rest of the section explains these commands. Enter these commands at the NDR Config > prompt.

*Table 12. Network Dispatcher Configuration Commands*

Command	Function
? (Help)	Displays all the commands available for this command level or lists the options for specific commands (if available). See “Getting Help” on page xxxii.
Add	Configures various components of the Network Dispatcher including advisors, clusters, ports, and servers.
Clear	Clears the entire Network Dispatcher configuration.
Disable	Disables the backup, executor, and manager components of the Network Dispatcher. Also disables specific advisors.
Enable	Enables the backup, executor, and manager components of the Network Dispatcher. Also enables specific advisors.
List	Displays the entire Network Dispatcher Configuration or specific portions of the configuration.
Remove	Removes specific portions of the Network Dispatcher configuration.
Set	Changes the configuration parameters for advisors, clusters, ports, servers, or the Network Dispatcher manager.
Exit	Returns you to the previous command level. See “Exiting a Lower Level Environment” on page xxxii.

### Add

Use the **add** command to configure advisors, clusters, ports, servers, and reach addresses. For High Availability you can also configure whether this Network Dispatcher is a primary or backup and which IP addresses to use for heartbeat and database synchronization.

#### Syntax:

```
add                advisor . . .  
                   backup . . .  
                   cluster . . .
```

## Configuring Network Dispatcher

hearbeat . . .

port . . .

reach . . .

server . . .

### **Advisor** *name port# interval timeout comm-port*

Specifies the name and port for an advisor. This parameter also specifies how frequently the advisor will collect information on a particular protocol and a time period after which the advisor report is considered to be out of date.

**name** Specifies the type of advisor. Enter the advisor number that corresponds with the type of advisor you want to add.

Table 13. Advisor Names and Port Numbers

Advisor Number	Advisor Name	Default Port#
0	FTP	21
1	HTTP	80
2	MVS	10007
3	TN3270	23
4	SMTP	25
5	NNTP	119
6	POP3	110
7	TELNET	23
8	SSL	443

**Valid values:** 0 - 8

**Default value:** 1

**port#** Specifies the port number for this advisor.

**Valid values:** 1 to 65535

**Default values:** See Table 13.

### **interval**

Specifies the frequency, in seconds, with which the advisor queries its protocol for each server. After half of this value without a response from the server, the adviser considers the protocol unavailable.

**Valid values:** 1 to 65535

**Default value:** 5

### **timeout**

Specifies the interval of time, in seconds, after which the advisor report is considered to be out of date.

To make sure that out-of-date information is not used by the manager in its load-balancing decisions, the manager will not use information from the advisor whose time stamp is older than the time set in this parameter. The advisor timeout should be larger than the advisor polling interval. If the timeout is smaller, the manager will ignore reports that should be used. By default, advisor reports do not time out.

## Configuring Network Dispatcher

This timeout value typically applies if you disable an advisor. Do not confuse this parameter with the interval/2 timeout previously described, which relates to a server not responding.

**Valid values:** 0 to 65535

**Default value:** 0, which means the advisor report never times out.

### comm-port

Specifies the port number used by the TN3270 advisor to communicate with the TN3270 servers. This parameter is input only for the TN3270 advisor. It must match the advisor port number set in the TN3270 server configuration.

**Valid values:** 1 to 65535

**Default value:**

- TN3270 default:10008

**Note:** Because the manager component is a prerequisite for the advisor, you must enable the manager before any advisor can be enabled. You must also set the manager proportions so that the manager will consider advisor input when setting the server weights that are used to make load balancing decisions. You must also set the internal IP address using the **set internal-ip-address** command for the advisor to run correctly. See *Configuring and Monitoring IP in Protocol Configuration and Monitoring Reference Volume 1* for more information about the **set internal-ip-address** command.

### Example 1:

```
add advisor
Advisor name (0=ftp,1=http,2=MVS,3=TN3270,4=smtp,5=nntp,6=pop3,7=telnet,8=SSL) [1]? 1
Port number [80]?
Interval (seconds) [5]? 10
Timeout (0=unlimited) [0]? 10
```

### Example 2:

```
add advisor
Advisor name (0=ftp,1=http,2=MVS,3=TN3270,4=smtp,5=nntp,6=pop3,7=telnet,8=SSL) [1]? 3
Port number [23]?
Interval (seconds) [5]? 10
Timeout (0=unlimited) [0]? 10
Communication Port number [10008]?
```

### backup role strategy

Specifies whether this Network Dispatcher is a backup or primary.

**role** Defines whether this is a primary or a backup Network Dispatcher. Use this command only if you intend to have a redundant configuration, and want the High Availability function to run. In this case, you must also configure the heartbeat (**add heartbeat**) and reachability (**add reach**).

**Valid values:** 0 or 1

0 = primary

1 = backup

**Default value:** 0

### strategy

Specifies whether the Network Dispatcher will switch back to primary mode automatically or manually. Whenever a Primary Network Dispatcher fails and becomes standby (which means a

## Configuring Network Dispatcher

backup performed the IP takeover function), and then becomes available, it will automatically become the active Network Dispatcher if the strategy is set to *automatic*, as soon as the databases are synchronized. If strategy is set to *manual*, the old primary will go to standby mode and the operator must use the **switchover** command in talk 5 to make it active again. See “Switchover” on page 139.

**Valid values:** 0 or 1

0 = automatic

1 = manual

**Default value:** 0

### Example:

```
add backup
Role (0=Primary, 1=Backup) [0]?
Switch back strategy (0=Auto, 1=Manual) [0]?
```

**cluster** *address FIN-count FIN-timeout Stale-timer Advertise-cluster-address Advertise-route-cost*

Specifies a cluster’s IP address and the frequency for the executor to perform garbage collection from the Network Dispatcher database. If you configure cluster addresses to be advertised, see “Using Network Dispatcher with Cluster Address Advertising” on page 109 for more information. For cluster addresses that are not configured to be advertised, you must select cluster addresses that are part of an advertised subnet that is local to the Network Dispatcher machine. This would typically be the subnet on which Network Dispatcher receives client traffic from the next hop router.

**Note:** Cluster IP Addresses must not match the internal IP address of the router and must not match any interface IP addresses defined on the router. If you are running Network Dispatcher and TN3270 server in the same machine, the cluster address can match an IP address defined on the loopback interface. See “Using Network Dispatcher with TN3270 Server” on page 106 for more information.

### address

Specifies the IP address for the cluster.

**Valid values:** Any valid IP address

**Default value:** 0.0.0.0

### FIN-count

Specifies the number of connections that must be in FIN state before the executor tries to remove the unused connection information from the Network Dispatcher database after *FIN-timeout* or *Stale-timer* has elapsed.

**Valid Values:** 0 to 65535

**Default value:** 4000

### FIN-timeout

Specifies the number of seconds, that a connection has been in the FIN state, after which the executor tries to remove the unused connection information from the Network Dispatcher database.

**Valid Values:** 0 to 65535

**Default value:** 30

### Stale-timer

Specifies the number of seconds, that a connection has been inactive, after which the executor tries to remove a connection's information from the Network Dispatcher database.

**Valid Values:** 0 to 65535

**Default value:** 1500

### Advertise-cluster-address

Specifies whether the cluster address should be advertised.

**Valid Values:** yes or no

**Default value:** no

### Advertise-route-cost

Specifies the cost of the advertised route. This question is asked only if the answer to **advertise cluster address** is *yes*.

**Valid Values:** 0 to 4294967295

**Default value:** 0

### Example:

```
NDR Config>add cluster
Cluster Address [0.0.0.0]? 113.3.1.12
FIN count [4000]?
FIN time out [30]?
Stale timer [1500]?
Advertise cluster address [No]? y
Advertise route cost [0]? 20
Cluster 113.3.1.12 has been added.
Fincount has been set to 4000 for cluster 113.3.1.12
Fintimeout has been set to 30 for cluster 113.3.1.12
Staletimer has been set to 1500 for cluster 113.3.1.12
NDR Config>
```

### heartbeat *address1 address2*

Specifies one path for Heartbeat messages. The Heartbeat message will flow from *address1*, which belongs to this Network Dispatcher, to *address2*, which belongs to the peer Network Dispatcher.

**Note:** Configuring more than one heartbeat path between the primary and backup Network Dispatchers is required to ensure that the failure of a single interface will not disrupt the heartbeat communication between the primary and backup machines.

If you have only one existing LAN connection between the two Network Dispatchers, the second heartbeat could be set up over a simple LAN connection (a crossover cable used directly between two Ethernet ports) or a point-to-point serial connection (back-to-back PPP connection over a null-modem cable using unnumbered IP).

### address1

Specifies the IP address of the interface of this Network Dispatcher from which Heartbeat messages will flow.

**Valid Values:** Any IP address.

**Default value:** 0.0.0.0

### address2

Specifies the IP address of the interface of the peer Network

## Configuring Network Dispatcher

Dispatcher to which Heartbeat messages will flow. This address must be reachable from the interface specified in *address1*.

**Valid Values:** Any IP address.

**Default value:** 0.0.0.0

### Example:

```
add heartbeat
Source Heartbeat address [0.0.0.0]? 131.2.25.90
Target Heartbeat Address [0.0.0.0]? 131.2.25.92
```

**port** *cluster-address port# port-type max-weight port-mode*

Specifies the port and port's attributes.

### cluster-address

Specifies the IP address of the cluster.

**Valid Values:** Any IP address.

**Default value:** 0.0.0.0

**port#** Specifies the port number of the protocol for this cluster.

**Valid Values:** 1 to 65535

**Default value:** 80

### port-type

Specifies the types of IP traffic that can be load balanced on this port. Supported types are:

- 1 = TCP
- 2 = UDP
- 3 = both

**Valid Values:** 1, 2, 3

**Default value:** 3

### max-weight

Specifies the maximum weight for servers on this port. This affects how much difference there can be between the number of requests the executor will give each server.

**Valid Values:** 0 to 100

**Default value:** 20

### port-mode

Specifies whether the port will feed all requests from a single client to a single server (known as sticky), use passive ftp (pftp), use Web Server Cache (cache), feed an external scalable cache array (extcache), use Host On-Demand Client Cache, or use no particular protocols on this cluster (none).

**Valid Values:** 0 - 5, where:

- 0 = none
- 1 = sticky
- 2 = pftp
- 3 = cache (only for devices with HPSC)
- 4 = extcache
- 5 = hod client cache (only for devices with HPSC)



**Default value:** 0

### Example:

```
Config>feature ndr
NDR>add cluster 1.2.3.4 4000 30 1500
NDR>add port
Cluster address [0.0.0.0]? 1.2.3.4
Port number [80]? 80
Port type [3]?
Maximum weight [20]?
Port mode [0=none, 1=sticky, 2=pftp, 3=cache 4=extcache 5=hod client cache ]? 0
```

### Notes:

1. When port mode 3 (cache=3) is selected see “Chapter 12. Configuring and Monitoring Web Server Cache” on page 197 for information about Web Server Cache.
2. When port mode 5 (hod client cache=5) is selected see “Chapter 10. Configuring and Monitoring IBM eNetwork Host On-Demand Client Cache” on page 143 for information about Web Server Cache.

### **reach** *address*

Specifies any host address that the Network Dispatcher must be able to reach to run correctly. It can be a server address, a router address, an administration station address or other IP host.

#### **address**

Specifies the target IP address.

**Valid Values:** Any IP address

**Default value:** 0.0.0.0

### Example:

```
add reach
Address to reach [0.0.0.0]?
```

### **server** *cluster-address port# server-address server-weight server-state*

Specifies the attributes of a server in a cluster.

#### **cluster-address**

Specifies the IP address of the cluster to which this server belongs.

**Valid Values:** Any IP address

**Default value:** 0.0.0.0

**port#** Specifies the protocol running over the connection to this server.

**Valid Values:** 1 to 65535

**Default value:** 80

#### **server-address**

Specifies the IP address of the server.

**Valid Values:** Any IP address

**Default value:** 0.0.0.0

#### **server-weight**

Specifies the weight of the server for the executor. This affects how frequently the Network Dispatcher sends requests to this particular server.

**Valid Values:** 0 to the value of *max-weight* specified on the add port command.

## Configuring Network Dispatcher

**Default value:** max-weight on port command

### server-state

Specifies whether the executor should regard the server as available or unavailable when the executor begins processing.

**Valid Values:** 0 (down) or 1 (up)

**Default value:** 1

### Example:

```
add server
Cluster address [0.0.0.0]? 131.2.25.91
Port number [80]? 80
Server address [0.0.0.0]? 131.2.25.94
Server weight [35]?
Server state (down=0 up=1) [1]?
```

## Parameter Configuration Limits

Table 14 lists the limits for the various items you can configure for a Network Dispatcher

Table 14. Parameter Configuration Limits

Parameter	Limit (with HPSC)	Limit (without HPSC)
Advisors	32 per 2212	8 per 2212
Clusters	100 per 2212	32 per 2212
Heartbeats	32 per 2212	8 per 2212
Ports	32 per cluster	8 per cluster
Reachs	32 per 2212	8 per 2212
Servers	128 per each configured port, 512 for each port number under all clusters configured for 2212.	32 per configured port, 128 for each port number under all clusters configured for 2212.
Unique server IP address	32 per 2212	32 per 2212

## Clear

Use the **clear** command to clear the entire Network Dispatcher configuration.

### Syntax:

**clear**

## Disable

Use the **disable** command to disable a Network Dispatcher component.

### Syntax:

```
disable          advisor . . .
                   backup
                   executor
                   manager
```

**advisor** *name port#*

Disables an advisor from the Network Dispatcher.

**name** Specifies the type of advisor. Enter the advisor number that corresponds with the type of advisor you want to disable.

See Table 13 on page 114 for additional information.

**Valid values:** 0 - 8

**Default value:** 0

**port#** Specifies the port number for this advisor.

**Valid values:** 1 to 65535

**Default value:** None. You must enter a port number.

**Example:**

```
disable advisor
Advisor name (0=ftp,1=http,2=MVS,3=TN3270,4=smtp,5=nnntp,6=pop3,7=telnet,8=SSL) [1]? 1
Port number [0]? 80
```

**backup**

Disables the Network Dispatcher's backup function.

**Example:**

```
disable backup
Backup is now disabled.
```

**executor**

Disables the Network Dispatcher executor. Disabling the executor disables the Network Dispatcher feature.

**Example:**

```
disable executor
Executor is now disabled.
```

**Note:** Disabling the executor will stop the manager, advisors, and the high availability function, if they are currently running.

**manager**

Disables the Network Dispatcher manager. The manager is an optional component. However, if you do not use the manager, the Network Dispatcher will balance the load using a round-robin scheduling method based on the current server weights.

**Example:**

```
disable manager
Manager is now disabled.
```

**Note:** Because the manager component is prerequisite for advisors, disabling the manager will stop all the advisors from running.

## Enable

Use the **enable** command to enable a Network Dispatcher component.

**Syntax:**

```
enable          advisor . . .
                  backup
                  executor
                  manager
```

**advisor name port#**

Enables an advisor to the Network Dispatcher.

**name** Specifies the type of advisor. Enter the advisor number that corresponds with the type of advisor you want to enable.

See Table 13 on page 114 for additional information.

## Configuring Network Dispatcher

**Valid values:** 0 - 8

**Default value:** 0

**port#** Specifies the port number for this advisor.

**Valid values:** 1 to 65535

**Default value:** None. You must enter a port number.

### Example:

```
enable advisor
Advisor name (0=ftp,1=http,2=MVS,3=TN3270,4=smtp,5=nntp=6=pop3,7=telnet,8=SSL) [1]? 1
Port number [0]? 80
```

**Note:** Because the manager component is a prerequisite for the advisor, you must enable the manager before any advisor can be enabled. You must also set the manager proportions so that the manager will consider advisor input when setting the server weights that are used to make load balancing decisions. You must also set the internal IP address using the **set internal-ip-address** command for the advisor to run correctly. See the chapter Configuring and Monitoring IP in *Protocol Configuration and Monitoring Reference Volume 1* for more information about the **set internal-ip-address** command.

### backup

Enables the Network Dispatcher's backup function.

**Example:** enable backup

**Note:** Before enabling backup, you must add at least one heartbeat

### executor

Enables the Network Dispatcher executor.

**Example:**

```
enable executor
Executor is now enabled.
```

### manager

Enables the Network Dispatcher manager.

**Example:**

```
enable manager
Manager interval was set to 2.
Manager proportions were set to 50 50 0 0
Manager refresh cycle was set to 2
Manager sensitivity was set to 5.
Manager smoothing factor was set to 1.50.
```

When the manager is enabled for the first time, a manager record is created with the following default values:

**Interval:** 2 seconds

**Refresh-Cycle:** 2

**Sensitivity:** 5 %

**Smoothing:** 1.5

**Proportions:**

**Active:** 50%

**New:** 50%

## Configuring Network Dispatcher

**Advisor:** 0

**System:** 0

See "Set" on page 126 for a description of the above parameters.

## List

Use the **list** command to display information about the Network Dispatcher.

### Syntax:

**list** all  
advisor  
backup  
cluster  
manager  
port  
server

**all** Displays all Network Dispatcher configuration information. This includes the same information displayed for advisors, backup, cluster, manager, ports, and servers.

### Example:

```
NDR Config> list all
```

```
Executor: Enabled
```

```
Manager: Enabled
```

```
Interval      Refresh-Cycle  Sensitivity    Smoothing
2             2              5 %           1.50
Proportions:  Active New      Advisor        System
50 %         50 %         0 %           0 %
```

```
Advisor:
```

```
Name  Port  Interval  TimeOut  State  CommPort
http  80    5         0        Enabled
MVS   10007 15        0        Enabled
TN3270 23    5         0        Enabled 10008
```

```
Backup: Enabled
```

```
Role      Strategy
PRIMARY   AUTOMATIC
```

```
Reachability: Address      Mask          Type
131.2.25.93  255.255.255.255 HOST
131.2.25.94  255.255.255.255 HOST
```

```
HeartBeat Configuration:
```

```
Source Address: 131.2.25.90 Target Address: 131.2.25.92
Source Address: 132.2.25.90 Target Address: 132.2.25.92
```

```
Clusters:
```

```
Cluster-Addr  FIN-count  FIN-timeout  Stale-timer  Advertise/Cost
131.2.25.91   4000       30           1500         Yes / 20
```

```
Ports:
```

```
Cluster-Addr  Port#  Weight  Port-Mode  Port-Type
131.2.25.91   23    20 %   none      TCP
131.2.25.91   80    20 %   none      Both
```

```
Servers:
```

```
Cluster-Addr  Port#  Server-Addr  Weight  State
131.2.25.91   23    131.2.25.93  20 %   up
131.2.25.91   23    131.2.25.94  20 %   up
131.2.25.91   80    131.2.25.93  20 %   up
131.2.25.91   80    131.2.25.94  20 %   up
```

### advisor

Displays the configuration for the Network Dispatcher advisors.

## Configuring Network Dispatcher

### **backup**

Displays the backup configuration for the Network Dispatcher.

### **cluster**

Displays the configuration of the Network Dispatcher clusters.

### **manager**

Displays the configuration of the Network Dispatcher manager.

### **port**

Displays the configuration of the Network Dispatcher ports.

### **server**

Displays the configuration of the servers associated with the Network Dispatcher clusters.

## Remove

Use the **remove** command to delete part of the Network Dispatcher configuration.

### **Syntax:**

```
remove          advisor . . .  
                  backup  
                  cluster . . .  
                  heartbeat . . .  
                  port . . .  
                  reach . . .  
                  server . . .
```

### **advisor** *name port#*

Removes a specific advisor from the Network Dispatcher configuration.

**name** Specifies the type of advisor. Enter the advisor number that corresponds with the type of advisor you want to remove.

See Table 13 on page 114 for additional information.

**Valid values:** 0 - 8

**Default value:** 0

**port#** Specifies the port number for this advisor.

**Valid values:** 1 to 65535

**Default value:** None. You must enter a port number.

### **Example:**

```
remove advisor  
Advisor name (0=ftp,1=http,2=MVS,3=TN3270,4=smtp,5=nnntp,6=pop3,7=telnet,8=SSL) [0]?  
Advisor port [0]? 80
```

### **backup**

Removes the high availability function.

**Note:** Because backup is a prerequisite for the heartbeat and reach functions removing backup will stop heartbeat and reach from running.

**Example: remove backup**

### **cluster** *address*

Removes a cluster from the Network Dispatcher configuration.

### **address**

Specifies the IP address for the cluster.

**Valid values:** Any valid IP address

**Default value:** 0.0.0.0

**Note:** Removing a cluster address also removes all the ports and servers associated with that cluster.

### **Example:**

```
remove cluster
WARNING: Deleting a cluster will make any port or server
        associated with it to also be deleted.
Cluster address [0.0.0.0]? 131.2.25.91
```

### **heartbeat address**

Removes the heartbeat address from the Network Dispatcher configuration.

### **address**

Specifies the IP address for the target Network Dispatcher.

**Valid values:** Any valid IP address

**Default value:** 0.0.0.0

### **Example:**

```
remove heartbeat
Target address [0.0.0.0]? 131.2.25.92
```

### **port cluster-address port#**

Removes a port from a specific cluster in the Network Dispatcher configuration.

### **cluster-address**

Specifies the IP address of the cluster.

**Valid Values:** Any IP address.

**Default value:** 0.0.0.0

**port#** Specifies the port number of the protocol for this cluster.

**Valid Values:** 1 to 65535

**Default value:** None. You must enter a port number.

### **Notes:**

1. Removing a port will also remove all of the servers associated with that port.
2. If the port mode for the port being removed is cache, the associated Web Server Cache Proxy configuration will also be removed.
3. If the port mode for the port being removed is Host On-Demand Client Cache, the associated Host On-Demand Client Cache Proxy configuration will also be removed.

### **Example:**

```
remove port
WARNING: Deleting a port will make any server
        associated with it also be deleted.  [0.0.0.0]? 7.82.142.15
Port number [0]? 80
Cluster address [0.0.0.0]? 20.21.22.15
```

### **reach address**

Removes a server from the list of hosts the Network Dispatcher must be able to reach.

## Configuring Network Dispatcher

### address

Specifies the IP address of the cluster.

**Valid Values:** Any IP address.

**Default value:** 0.0.0.0

### Example:

```
remove reach
Target address [0.0.0.0]? 9.82.142.15
```

**server** *cluster-address port# server-address*

Removes a server from a cluster and port in the Network Dispatcher configuration.

### cluster-address

Specifies the IP address of the cluster.

**Valid Values:** Any IP address.

**Default value:** 0.0.0.0

**port#** Specifies the port number of the protocol for this cluster.

**Valid Values:** 1 to 65535

**Default value:** None. You must enter a port number.

### server-address

Specifies the IP address of the cluster.

**Valid Values:** Any IP address.

**Default value:** 0.0.0.0

### Example:

```
remove server
Cluster address [0.0.0.0]? 7.82.142.15
Port number [0]? 80
Server address [0.0.0.0]? 20.21.22.15
```

## Set

Use the **set** command to change the attributes of an existing advisor, cluster, port, or server. You can also define attributes for the Network Dispatcher manager.

### Syntax:

```
set                                advisor . . .
                                     cluster . . .
                                     manager . . .
                                     port . . .
                                     server . . .
```

**advisor** *name port# interval timeout comm-port*

Changes the port number, interval, and timeout for an advisor.

**name** Specifies the type of advisor. Enter the advisor number that corresponds with the type of advisor you want to set.

See Table 13 on page 114 for additional information.

**Valid values:** 0 - 8

**Default value:** 0



## Configuring Network Dispatcher

**port#** Specifies the port number for this advisor.

**Valid values:** 1 to 65535

**Default value:** None. You must enter a port number.

### interval

Specifies the frequency with which the advisor queries its protocol for each server. After half of this value expires without a response from the server, the adviser considers the protocol unavailable.

**Valid values:** 0 to 65535

**Default value:** 5

### timeout

Specifies the interval of time, in seconds, after which the advisor considers the protocol unavailable.

To make sure that out-of-date information is not used by the manager in its load-balancing decisions, the manager will not use information from the advisor whose time stamp is older than the time set in this parameter. The advisor timeout should be larger than the advisor polling interval. If the timeout is smaller, the manager will ignore reports that should be used. By default, advisor reports do not time out.

This timeout value typically applies if you disable an advisor. Do not confuse this parameter with the interval/2 timeout previously described, which relates to a server not responding.

**Valid values:** 0 to 65535

**Default value:** 0, which means the protocol is considered always available.

### comm-port

Specifies the port number used by the TN3270 advisor to communicate with the TN3270 servers. This parameter is input only for the TN3270 advisor.

**Valid values:** 1 to 65535

**Default value:**

- TN3270 default:10008

### Example:

```
set advisor
Advisor name (0=ftp,1=http,2=MVS,3=TN3270,4=smt,5=nntp=6=pop3,7=telnet,8=SSL) [0]?
Port number [0]? 21
Interval (seconds) [5]? 10
Timeout (0=unlimited) [0]? 20
```

### cluster *address FIN-count FIN-timeout Stale-timer*

Changes the FIN-count, FIN-timeout, and Stale-timer for a cluster in the Network Dispatcher configuration.

#### address

Specifies the IP address for the cluster.

**Valid values:** Any valid IP address

**Default value:** 0.0.0.0

## Configuring Network Dispatcher

### FIN-count

Specifies the number of connections that must be in FIN state before the executor tries to remove the unused connection information from the Network Dispatcher database after *FIN-timeout* or *Stale-timer* has elapsed.

**Valid Values:** 0 to 65535

**Default value:** 4000

### FIN-timeout

Specifies the number of seconds after which the executor tries to remove the unused connection information from the Network Dispatcher database.

**Valid Values:** 0 to 65535

**Default value:** 30

### Stale-timer

Specifies the number of seconds that a connection has been inactive, after which the executor tries to remove a connection's information from the Network Dispatcher database.

**Valid Values:** 0 to 65535

**Default value:** 1500

### Example:

```
set cluster
Cluster address [0.0.0.0]? 131.2.25.91
FIN count [4000]? 4500
FIN timeout [30]? 40
Stale timer [1500]? 2000
```

### **manager** *interval proportion refresh sensitivity smoothing*

Sets the values that the manager uses to determine the best server to satisfy a request.

#### **interval**

Specifies the amount of time, in seconds, after which the manager updates the server weights that the executor uses in load balancing connections.

**Valid values:** 0 to 65535

**Default value:** 2

#### **proportion**

Specifies the relative importance of external factors in the manager's weighting decisions. The sum of the proportions must equal 100. The factors are:

**active** The number of active connections on each TCP/IP server as tracked by the executor.

**Valid values:** 0 to 100

**Default value:** 50

**new** The number of new connections on each TCP/IP server as tracked by the executor.

**Valid values:** 0 to 100

**Default value:** 50

## Configuring Network Dispatcher

### advisor

Input from the protocol advisors defined to the Network Dispatcher.

**Valid values:** 0 to 100

**Default value:** 0

### system

Input from the MVS system advisor provided by the MVS WLM system monitoring tool.

**Valid values:** 0 to 100

**Default value:** 0

### refresh

Specifies the frequency with which the manager requests status from the executor. This parameter is specified as a number of *intervals*.

**Valid values:** 0 to 100

**Default value:** 2

### sensitivity

Specifies the percentage weight change for all the servers on a port, after which the manager updates the weights that the executor uses in load balancing connections.

**Valid values:** 0 to 100

**Default value:** 5

### smoothing

Specifies a limit to the amount that a server's weight can change. Smoothing minimizes the frequency of change in the distribution of requests. A higher smoothing index will cause the weights to change less. A lower smoothing index will cause the weights to change more.

**Valid values:** a decimal value between 1.0 and 42 949 673.00

**Default value:** 1.5

**Note:** You can only specify two places after the decimal point.

### Example:

```
set manager
Interval (in seconds) [2]? 3
Active proportion [50]? 40
New proportion [50]? 38
Advisor proportion [0]? 20
System proportion [0]? 2
Refresh cycle [2]? 4
Sensitivity threshold [5]? 10
Smoothing index (>1.00) [1.50]? 200
```

### port *cluster-address port# port-type max-weight port-mode*

Changes the port-type, max-weight, and port-mode for a specific cluster and port number.

#### cluster-address

Specifies the IP address of the cluster.

**Valid Values:** Any IP address.

**Default value:** 0.0.0.0

## Configuring Network Dispatcher

**port#** Specifies the port number of the protocol for this cluster.

**Valid Values:** 1 to 65535

**Default value:** None. You must enter a port number.

### **port-type**

Specifies the type of IP traffic that can be load balanced on this port.

**Valid Values:**

- 1 = TCP
- 2 = UDP
- 3 = both

**Default value:** 3

### **max-weight**

Specifies the weight for servers on this port. This affects how much difference there can be between the number of requests the executor will give each server.

**Valid Values:** 0 to 100

**Default value:** 20

### **port-mode**

Specifies whether the port will feed all requests from a single client to a single server (known as sticky), use passive ftp (pftp), use Web Server Cache (cache), feed an external scalable cache array, use Host On-Demand Client Cache, or use no protocols on this cluster (none).

**Valid Values:**

- 0 = none
- 1 = sticky
- 2 = pftp
- 3 = cache (only for devices with HPSC)
- 4 = extcache
- 5 = hod client cache (only for devices with HPSC)

**Default value:** 0 (none)

### **Example:**

```
set port
Cluster address [0.0.0.0]? 131.2.25.91
Port number [0]? 23
Port type (tcp=1, udp=2, both=3) [3]?
Max. weight (0-100) [20]? 30
Port mode (none=0, sticky=1, pftp=2, cache=3, extcache=4 hod client cache=5) [0]?
```

### **Notes:**

1. When port mode 3 (cache=3) is selected see “Chapter 12. Configuring and Monitoring Web Server Cache” on page 197 for information.
2. When port mode 5 (hod client cache=5) is selected see “Chapter 10. Configuring and Monitoring IBM eNetwork Host On-Demand Client Cache” on page 143 for information.

**server** *cluster-address port# server-address weight state*

Changes the server state, and server weight for a specific server in a cluster.

## Configuring Network Dispatcher

### cluster-address

Specifies the IP address of the cluster to which this server belongs.

**Valid Values:** Any IP address

**Default value:** 0.0.0.0

**port#** Specifies the port number of the protocol for this cluster.

**Valid Values:** 1 to 65535

**Default Value:** None. You must enter a port number.

### server-address

Specifies the IP address of the server.

**Valid Values:** Any valid server address

**Default Value:** 0.0.0.0

**state** Specifies whether the executor should regard the server as available or unavailable when the executor begins processing.

**Valid Values:** 0 (down) or 1 (up)

**Default value:** 1

### weight

Specifies the weight of the server for the executor. This affects how frequently the Network Dispatcher sends requests to this particular server.

**Valid Values:** 0 to the value of *max-weight* specified on the add port command.

**Default value:** max-weight on port command

### Example:

```
set server
Cluster address [0.0.0.0]? 131.2.25.91
Port number [0]?
Server address [0.0.0.0]?
Server weight [20]? 25
Server state (down=0, up=1) [1]? 1
```

---

## Accessing the Network Dispatcher Monitoring Commands

To access the Network Dispatcher monitoring environment:

1. Enter **talk 5** at the OPCON prompt (\*).
2. Enter **feature ndr** at the GWCON prompt (+).

Network Dispatcher may also be monitored using SNMP. Refer to “SNMP Management” in the *Protocol Configuration and Monitoring Reference Volume 1* for more information.

### Network Dispatcher Monitoring Commands

Table 15 summarizes the Network Dispatcher monitoring commands and the rest of the section explains these commands. Enter these commands at the NDR > prompt.

Table 15. Network Dispatcher Monitoring Commands

Command	Function
? (Help)	Displays all the commands available for this command level or lists the options for specific commands (if available). See “Getting Help” on page xxxii.
List	Displays the currently configured attributes of the advisor, clusters, ports, or servers.
Quiesce	Specifies that no more connection request should be sent to a server. Also temporarily stops the heartbeat and reach functions.
Report	Displays a report of information related to the advisor and the manager.
Status	Displays the current status of the counters, clusters, ports, servers, advisor, manager, and backup.
Switchover	Forces a Network Dispatcher that is running in standby mode to become the active Network Dispatcher. Use of this command is necessary if you specified manual as the switchover mode.
Unquiesce	Allows the Network Dispatcher manager to assign a weight greater than 0 to a previously quiesced server on every port that the server is configured. This action allows new connection requests to flow to the selected server.
Exit	Returns you to the previous command level. See “Exiting a Lower Level Environment” on page xxxii.

## List

Use the **list** command to display information about the Network Dispatcher.

### Syntax:

```
list          _advisor
              _cluster
              _port
              _server
```

### advisor

Displays the configuration for the Network Dispatcher advisors that are currently enabled..

#### Example:

```
list advisor
Advisor list requested.
```

ADVISOR	PORT	TIMEOUT	STATUS
ftp	21	5	ACTIVE
Http	80	unlimited	ACTIVE
MVS	10007	unlimited	ACTIVE
TN3270	23	unlimited	ACTIVE

### cluster

Displays the configuration of the Network Dispatcher clusters.

#### Example:

```
list cluster
EXECUTOR INFORMATION:
-----
Version: 01.01.00.00 - Tue Dec 10 14:15:58 EST 1996
Number of defined clusters: 2

CLUSTER LIST:
-----
131.2.25.91
10.11.12.2
```

**port** Displays the configuration of the Network Dispatcher ports.

**Example:**

```
list port
Cluster Address [0.0.0.0]? 131.2.25.91
```

CLUSTER: 131.2.25.91			
PORT	MAXWEIGHT	PORT MODE	PORT TYPE
23	30	none	TCP
80	20	none	both

**server** Displays the configuration of the servers associated with the Network Dispatcher clusters.

**Example:**

```
list server
Cluster Address [0.0.0.0]? 131.2.25.91

PORT 23 INFORMATION:
-----
Maximum weight..... 20
Port mode..... NONE
Port type..... TCP
All up nodes are weight zero... FALSE
Total target nodes..... 2
Currently marked down..... 0
Servers providing service to this port:
Address: 131.2.25.93 Weight: 20 Count: 0 TCP Count: 0 UDP Count: 0
Active: 0 FIN 0 Complete 0 Status: up Saved Weight: -1
Address: 131.2.25.94 Weight: 20 Count: 0 TCP Count: 0 UDP Count: 0
Active: 0 FIN 0 Complete 0 Status: up Saved Weight: -1
PORT 80 INFORMATION:
-----
Maximum weight..... 20
Port mode..... NONE
Port type..... BOTH
All up nodes are weight zero... FALSE
Total target nodes..... 2
Currently marked down..... 0
Servers providing service to this port:
Address: 131.2.25.93 Weight: 20 Count: 0 TCP Count: 0 UDP Count: 0
Active: 0 FIN 0 Complete 0 Status: up Saved Weight: -1
Address: 131.2.25.94 Weight: 20 Count: 0 TCP Count: 0 UDP Count: 0
Active: 0 FIN 0 Complete 0 Status: up Saved Weight: -1
```

See page 138 for a description of the displayed information.

## Quiesce

Use the **quiesce** command to temporarily stop the heartbeat or reach functions or to specify that no more connection requests should be sent to a server.

**Syntax:**

```
quiesce          heartbeat
                 manager
                 reach
```

## Configuring Network Dispatcher

### **heartbeat** *address*

Stops the selected path for the heartbeat function. The *address* is the IP address of the remote network dispatcher to which this Network Dispatcher is sending Heartbeat messages.

#### **Example:**

```
quiesce heartbeat
Remote Address [0.0.0.0]? 131.2.25.94
```

### **manager** *address*

Specifies that no more connection requests are to be made to the specified server. *Address* is the IP address of the server.

#### **Example:**

```
quiesce manager
Server Address [0.0.0.0]? 131.2.25.93
```

### **reach** *address*

Stops the Network Dispatcher's polling of the specified address to determine if it is reachable, where *address* is the IP address that is part of the reachability criteria.

#### **Example:**

```
quiesce reach
Reach Address [0.0.0.0]? 131.2.25.92
```

## Report

Use the **report** command to display a report of the advisor or manager

### **Syntax:**

```
report advisor
          manager
```

### **advisor** *type port#*

Displays a report of information about a specific advisor.

**type** Is the type of advisor. Enter the advisor number that corresponds to the type of advisor. See Table 13 on page 114 for advisor types.

**port#** Is the port number.

#### **Example:**

```
report advisor
0=ftp,1=http,2=MVS,3=TN3270,4=smt,5=nntp,6=pop3,7=telnet,8=SSL
Advisor name [0]? 1
Port number [0]? 80
```

ADVISOR:	http
PORT:	80
131.2.25.93	0
131.2.25.94	16

The value shown for each server address represents:

**≥ 0** Server load

**-1** Advisor could not contact server.

### **manager**

Displays a report of the current manager information.

#### **Example:**



## Configuring Network Dispatcher

report manager

HOST TABLE LIST	STATUS
131.2.25.93	ACTIVE
131.2.25.94	ACTIVE

The reported information is:

**Status** Displays the status of the server address.  
**Quiesce** Server has been quiesced.  
**Active** Server has not been quiesced.

131.2.25.91	WEIGHT	ACTIVE % 50	NEW % 50	PORT % 0	SYSTEM % 0					
PORT: 23	NOW	NEW	WT	CONNECT	WT	CONNECT	WT	LOAD	WT	LOAD
131.2.25.93	10	10	10	0	10	0	0	0	-999	-1
131.2.25.94	10	10	10	0	10	0	0	0	-999	-1
PORT TOTALS:	20	20		0		0		0		-2

131.2.25.91	WEIGHT	ACTIVE % 50	NEW % 50	PORT % 0	SYSTEM % 0					
PORT: 80	NOW	NEW	WT	CONNECT	WT	CONNECT	WT	LOAD	WT	LOAD
131.2.25.93	10	10	10	0	10	1	16	0	-999	-1
131.2.25.94	10	10	10	0	10	1	3	16	-999	-1
PORT TOTALS:	20	20		0		0		16		-2

ADVISOR	PORT	TIMEOUT	STATUS
http	80	unlimited	ACTIVE
MVS	10007	unlimited	ACTIVE

Manager report requested.

The reported information is:

**Weight** The overall weight calculation for this server.  
**Now** The previous weight assigned to the server.  
**New** The newest weight assigned to the server.  
**Active %** The active connection proportion for the overall server weight calculation. The value of this parameter is established using the **set manager proportions** command. See page 128.  
**Wt** The weight used for overall weight calculation.  
**Connect** Number of active connections for this server.  
**New %** The new connection proportion for the overall server weight calculation. The value of this parameter is established using the **set manager proportions** command. See page 128.

## Configuring Network Dispatcher

**Wt** The weight used for overall weight calculation.

### Connect

Number of new connections for this server.

### Port %

The advisor proportion for the overall server weight calculation. The value of this parameter is established using the **set manager proportions** command. See page 128.

**Wt** The weight used for overall weight calculation.

**Load** Server load reported by advisor for this server.

### System %

The system monitor proportion for the overall server weight calculation. The value of this parameter is established using the **set manager proportions** command. See page 128.

**Wt** The weight used for overall weight calculation.

**Load** Server load reported by system monitor.

## Status

Use the **status** command to obtain the status of the advisors, backup, counter, clusters, manager, ports, and servers.

### Syntax:

```
status          advisor
                  backup
                  cluster
                  counter
                  manager
                  ports
                  servers
```

### **advisor** *name port#*

Obtains the status of a specific advisor.

**name** Specifies the type of advisor. Enter the advisor number that corresponds to the type of advisor. See Table 13 on page 114 for advisor types.

**port#** Is the port number.

### Example:

```
status advisor
0=ftp, 1=http, 2=MVS 3=TN3270, 4=SMTP, 5=NNTP, 6=POP3, 7=TELNET, 8=SSL
Advisor name [0]?
Port number [0]? 21

Advisor ftp on port 21 status:
=====
Interval..... 10
```

### **backup**

Obtains the status of the backup function.

### Example:

```
status backup
Dumping status ...
Role : PRIMARY Strategy : AUTOMATIC State : ND_ACTIVE Sub-State : ND_SYNCHRONIZED
<<Preferred Target : 132.2.25.92>>
```

```
Dumping HeartBeat Status ...
.....Heartbeat target : 131.2.25.92 Status : UNREACHABLE
.....Heartbeat target : 132.2.25.92 Status : REACHABLE

Dumping Reachability Status ...
.....Host:131.2.25.93 Local:REACHABLE
.....Host:131.2.25.94 Local:REACHABLE
```

### cluster *address*

Obtains the status of a specified cluster, where *address* is the IP address of the cluster.

#### Example:

```
status cluster
Cluster Address [0.0.0.0]? 131.2.25.91

EXECUTOR INFORMATION:
-----
Version: 01.01.00.00 - Tue Dec 10 14:15:58 EST 1996

CLUSTER INFORMATION:
-----
Address..... 131.2.25.91
Number of target ports..... 2
FIN clean up count..... 4000
Connection FIN timeout..... 30
Active connection stale timer... 1500
Advertise cluster address..... Yes
Advertise route cost..... 20

PORT 23 INFORMATION:
-----
Maximum weight..... 20
Port mode..... NONE
Port type..... TCP
All up nodes are weight zero... FALSE
Total target nodes..... 2
Currently marked down..... 0
Servers providing service to this port:
Address: 131.2.25.93 Weight: 20 Count: 0 TCP Count: 0 UDP Count: 0 Active:
0 FIN 0 Complete 0 Status: up Saved Weight: -1 Address: 131.2.25.94 Weight:
20 Count: 0 TCP Count: 0 UDP Count: 0 Active: 0 FIN 0 Complete 0 Status:
up Saved Weight: -1
PORT 80 INFORMATION:
-----
Maximum weight..... 20
Port type..... BOTH
Port mode..... NONE
All up nodes are weight zero... FALSE
Total target nodes..... 2
Currently marked down..... 0
Servers providing service to this port:
Address: 131.2.25.93 Weight: 20 Count: 0 TCP Count: 0 UDP Count: 0 Active:
0 FIN 0 Complete 0 Status: up Saved Weight: -1 Address: 131.2.25.94 Weight:
20 Count: 0 TCP Count: 0 UDP Count: 0 Active: 0 FIN 0 Complete 0 Status:
up Saved Weight: -1
```

See page 138 for definitions of the displayed fields.

### counter

Obtains the status of all counters.

#### Example:

```
status counter
Internal counters from executor:
-----
Total number of packets into executor..... 2684
Total packets for cluster processing (C)... 2684
Packets not addressed to a cluster(port)... 0

Cluster processing results:
-----
Errors..... 0
Discarded..... 0
Own address..... 0
Forward requested..... 2684
Forward discarded with error..... 0

Other processing problems:
-----
Total packets dropped (C)..... 0
```

## Configuring Network Dispatcher

### manager

Obtains the status of the manager.

#### Example:

```
status manager
Number of defined hosts... 2
Sensitivity..... 0%
Smoothing factor..... 2
Interval..... 3
Weights refresh cycle.... 4

Active connections gauge proportion..... 40%
New connections counter(delta) proportion... 38%
Advisor gauge proportion..... 20%
System Metric proportion..... 2%

Manager status requested.
```

### port cluster-address port#

Obtains the status of a specific port, where:

*cluster-address*

is the IP address of the cluster.

*port#* is the port number on the cluster.

#### Example:

```
status port
Cluster Address [0.0.0.0]? 131.2.25.91
Port number [0]? 80

PORT 80 INFORMATION:
-----
Maximum weight..... 20
Port mode..... NONE
Port type..... BOTH
All up nodes are weight zero... FALSE
Total target nodes..... 2
Currently marked down..... 0
Servers providing service to this port:
Address: 131.2.25.93 Weight: 20 Count: 12345 TCP Count: 10000 UDP count 2345
Active: 3431 FIN 3780 Complete 3431 Status: up Saved Weight: -1
Address: 131.2.25.94 Weight: 20 Count: 7890 Active: 2980 FIN 2390 Status: up
Saved Weight: -1
```

The reported server information is:

<b>Address</b>	Server IP address
<b>Weight</b>	Weight currently assigned to this server
<b>Count</b>	Cumulative count of TCP connections and UDP packets
<b>TCP Count</b>	Cumulative count of TCP connections
<b>UDP Count</b>	Cumulative count of UDP packets
<b>Active</b>	Number of active TCP connections
<b>FIN</b>	TCP connections is FIN state
<b>Complete</b>	TCP connections that are complete (ACK seen after FIN)
<b>Status</b>	Configured server state:
	<b>active</b> The server is active.
	<b>down</b> The server is down.
	<b>quiesced</b> The server is quiesced.
	<b>not responding</b> The server is not responding to the advisor.

## Configuring Network Dispatcher

**Saved weight** Server weight prior to server being marked down

### **server** *address*

Obtains the status of a specific server, where *address* is the IP address of the cluster to which the server belongs.

#### **Example:**

```
status server
Cluster Address [0.0.0.0]? 131.2.25.91

PORT 23 INFORMATION:
-----
Maximum weight..... 20
Port mode..... NONE
Port type..... TCP
All up nodes are weight zero... FALSE
Total target nodes..... 2
Currently marked down..... 0
Servers providing service to this port:
Address: 131.2.25.93 Weight: 20 Count: 140 TCP Count: 100 UDP Count: 40
Active: 50 FIN 45 Complete 50 Status: up Saved Weight: -1
Address: 131.2.25.94 Weight: 20 Count: 250 TCP Count: 100 UDP Count: 40
Active: 60 FIN 54 Complete 50 Status: up Saved Weight: -1

PORT 80 INFORMATION:
-----
Maximum weight..... 20
Port mode..... NONE
Port type..... BOTH
All up nodes are weight zero... FALSE
Total target nodes..... 2
Currently marked down..... 0
Servers providing service to this port:
Address: 131.2.25.93 Weight: 20 Count: 12345 TCP Count: 10000 UDP Count: 2345
Active: 3431 FIN 3780 Complete 3431 Status: up Saved Weight: -1
Address: 131.2.25.94 Weight: 20 Count: 7890 TCP Count: 10000 UDP Count: 2345
Active: 2980 FIN 2390 Complete 3431 Status: up Saved Weight: -1
```

## Switchover

Use the **switchover** command to force a Network Dispatcher that is running in standby mode to become the active Network Dispatcher when the switchover strategy is manual. This command must be entered on the host that is running the Network Dispatcher that is in standby mode.

#### **Syntax:**

**switchover**

## Unquiesce

Use the **unquiesce** command to restart a heartbeat, manager, or reach function that was previously stopped with the **quiesce** command.

#### **Syntax:**

```
unquiesce           heartbeat
                    manager
                    reach
```

### **heartbeat** *address*

Restarts the path for Heartbeat messages, where *address* is the IP address of the remote network dispatcher to which this Network Dispatcher is sending Heartbeat messages.

#### **Example:**

```
unquiesce heartbeat
Remote Address [0.0.0.0]? 9.10.11.1
```

## Configuring Network Dispatcher

### **manager** *address*

Restarts sending connection requests to the specified server. *Address* is the IP address of the server.

#### **Example:**

```
unquiesce manager  
Server Address [0.0.0.0]? 20.21.22.15
```

### **reach** *address*

Restarts the Network Dispatcher's polling of the specified address to determine if it is reachable, where *address* is the IP address that is part of the reachability criteria.

#### **Example:**

```
unquiesce reach  
Reach address [0.0.0.0]? 20.3.4.5
```

---

## Network Dispatcher Dynamic Reconfiguration Support

This section describes dynamic reconfiguration (DR) as it affects Talk 6 and Talk 5 commands.

### CONFIG (Talk 6) Delete Interface

The CONFIG (Talk 6) **delete interface** command is not applicable for NDR. Network Dispatcher is a feature and is not configured on an interface.

### GWCON (Talk 5) Activate Interface

The GWCON (Talk 5) **activate interface** command is not applicable for NDR. Network Dispatcher is a feature and is not configured on an interface.

### GWCON (Talk 5) Reset Interface

The GWCON (Talk 5) **reset interface** command is not applicable for NDR. Network Dispatcher is a feature and is not configured on an interface.

### CONFIG (Talk 6) Immediate Change Commands

NDR supports the following CONFIG commands that immediately change the operational state of the device. These changes are saved and are preserved if the device is reloaded, restarted, or you execute a dynamically reconfigurable command.

Commands
CONFIG, feature ndr, add advisor
CONFIG, feature ndr, add backup
CONFIG, feature ndr, add cluster
CONFIG, feature ndr, add heartbeat
CONFIG, feature ndr, add port
<b>Note:</b> If port mode selected is Web Server Client cache or Host On-Demand Client cache, the HTTP Proxy changes are not immediate.
CONFIG, feature ndr, add reach
CONFIG, feature ndr, add server
CONFIG, feature ndr, disable advisor
CONFIG, feature ndr, disable backup

<p>CONFIG, feature ndr, disable executor</p> <p><b>Note:</b> When executor is disabled, it removes all clusters, ports and servers from the runtime code structures, but <i>NOT SRAM</i>. If the port mode was Web Server Client Cache or Host On-Demand Client cache for a port that was removed, all Web Server Cache or the Host On-Demand Client cache partitions will be disabled and the HTTP Proxies will be closed.</p>
CONFIG, feature ndr, disable manager
CONFIG, feature ndr, enable advisor
CONFIG, feature ndr, enable backup
<p>CONFIG, feature ndr, enable executor</p> <p><b>Note:</b> When executor is enabled and there are Web Server Client cache or Host On-Demand Client cache ports, the HTTP Proxies and partitions are not automatic or immediate.</p>
CONFIG, feature ndr, enable manager
CONFIG, feature ndr, remove advisor
CONFIG, feature ndr, remove backup
<p>CONFIG, feature ndr, remove cluster</p> <p><b>Note:</b> Removing a cluster causes all ports and servers associated with that cluster to be removed from the runtime code structures and SRAM. If the port that was removed had a port mode of Web Server Client Cache or Host On-Demand Client cache, the HTTP proxy also goes down and its SRAM is removed.</p>
CONFIG, feature ndr, remove heartbeat
<p>CONFIG, feature ndr, remove port</p> <p><b>Note:</b> If the port being removed has a port mode of Web Server Client cache or Host On-Demand Client cache, the HTTP proxy also goes down and its SRAM is removed.</p>
CONFIG, feature ndr, remove reach
CONFIG, feature ndr, remove server
CONFIG, feature ndr, set advisor
CONFIG, feature ndr, set cluster
CONFIG, feature ndr, set manager
<p>CONFIG, feature ndr, set port</p> <p><b>Note:</b> If the port mode for this port was Web Server Client cache or Host On-Demand Client cache and it is now being set to something else, the HTTP proxies for those ports will be closed and its SRAM removed. Also, if the operational software is setting the port mode to cache or hod client cache from something else, the HTTP proxy changes are not immediate.</p>
CONFIG, feature ndr, set server

### Non-Dynamically Reconfigurable Commands

All NDR configuration parameters can be changed dynamically.





---

## Chapter 10. Configuring and Monitoring IBM eNetwork Host On-Demand Client Cache

Host On-Demand Client Cache allows Web-based clients to connect to SNA host applications using a Java™-based terminal emulation program, which connects the client to the host using TN3270. A less typical application of the Host On-Demand function is Telnet for emulation of non TN3270 terminals. It supports 3270, 5250, VT (VT52, VT100, VT220\_7\_BIT, VT220\_8\_BIT), and CICS gateway sessions.

The IP address of the Telnet servers is defaulted to the address of the Host On-Demand Server. This means that in the simplest configuration, the TN3270E server will be located external to the router.

In a more sophisticated setup, the Host On-Demand administrator will set up the Host On-Demand server specially so that its common session Telnet server address is the same as the Host On-Demand Client Cache cluster address (that is, the router(s) are employed as the TN3270E servers). This is the standard usage of Host On-Demand Client Cache as envisioned by the creators. In this configuration, the Network Dispatcher cluster address will have several associated ports: some for the Host On-Demand function and one (typically port 23) for the TN3270E function. See "Chapter 8. Using the Network Dispatcher Feature" on page 95 for details about configuration of TN3270E with Network Dispatcher. From the point of view of the Host On-Demand Server, it is programmed with an arbitrary Telnet server address. An HOD session may be programmed to use an arbitrary Telnet server, provided that signed applets are supported by the browser (generally this is true, but refer to *eNetwork Host On-Demand Version 3.0 Administrator's Guide*, IBM document number SC31-8627, for provisions required for OS/2). The Host On-Demand server used to provide terminal capabilities to clients is independent of the Telnet servers, which are directly related to the computers with which clients wish to communicate.

On the other hand, for a large configuration a number of TN3270E servers can be added to the Telnet port (port 23) under the Network Dispatcher configuration. For an extremely large configuration, additional ports can be set up as Telnet ports, since both the IP address and port (default 23) of a Telnet server can be configured in Host On-Demand sessions. Only one Host On-Demand server is required for these multi-Telnet server configurations that support tens of thousands of users.

This support allows a IBM 2212 acting as a TN3270E server to cache the terminal emulation applet and serve it to client browsers upon request. The applet is retrieved from a Web server the first time a client requests it and is stored in the Host On-Demand cache memory. Future client requests for the applet will be served directly from the cache, eliminating the need to do additional retrieves from the Web server.

For detailed information about using Host On-Demand from a client browser, refer to the chapter entitled "Understanding the Host On-Demand Clients" in *eNetwork Host On-Demand Version 3.0 Administrator's Guide*, IBM document number SC31-8627.

### Notes:

1. Host On-Demand Client Cache and the Web Server Cache feature cannot coexist in a configuration.
2. Host On-Demand runs only on the High Performance System Card.

## Configuring and Monitoring Host On-Demand Client Cache

3. Host On-Demand also supports connections to non-SNA hosts. It supports 3270, VT (VT52, VT100, VT220\_7\_BIT, VT220\_8\_BIT) and CICS gateway sessions.

This chapter describes how to configure the Host On-Demand Client Cache feature and use the Host On-Demand Client Cache monitoring commands. It contains the following sections:

- “Configuring the Host On-Demand Client Cache”
- “Accessing the Host On-Demand Client Cache Configuration Environment” on page 148
- “Host On-Demand Client Cache Commands” on page 148
- “Accessing the Host On-Demand Client Cache Monitoring Environment” on page 151
- “Host On-Demand Client Cache Monitoring Commands” on page 151
- “Host On-Demand Client Cache Dynamic Reconfiguration Support” on page 155

---

## Configuring the Host On-Demand Client Cache

Host On-Demand Client Cache must be used with Network Dispatcher. Before you use Host On-Demand Client Cache the first time you must:

1. Access Network Dispatcher in talk 6 from the Config> prompt using the **feature ndr** command.
2. Enable executor
3. Add a cluster
4. Add the following ports:
  - Add port 80 to the cluster and set it to hod client cache mode. Port 80 is the standard HTTP protocol port for the World Wide Web.
  - Add port 8999 to the cluster and accept the default values for all parameters other than the port number. Port 8999 is used by the clients to communicate with their group/user/session profiles that are stored on the Host On-Demand server.
  - It is assumed that the Host On-Demand Server administrator will access the Host On-Demand Server, directly, not through this IBM 2212, giving the system a security advantage due to the Network Dispatcher design, because only configured ports can be accessed by clients. However, if this is too restrictive, then add port 8989 to the cluster, and accept the default values for parameters.
5. Add one and only one Host On-Demand server. If additional Host On-Demand servers are desired for unusual administrative reasons, add them as unique clusters by repeating all steps starting from 144 above. The server must be added to each of the ports 80, 8999, and 8989 (if it is used).
6. If it is desired to have the router also be the TN3270E server, configure the Telnet port (23) under the cluster address following the procedure in “Chapter 8. Using the Network Dispatcher Feature” on page 95, and add the TN3270E servers to that port. It will also be necessary for the Host On-Demand Server administrator to simultaneously configure the Host On-Demand Server to use this alternate Telnet address.

Then you can use the configuration and monitoring commands to alter the Host On-Demand Client Cache environment.

**Note:** While the Network Dispatcher changes done via Talk 6 change the current running configuration, the changes for the Host On-Demand Client Cache do not change the current running configuration unless explicitly activated via

## Configuring and Monitoring Host On-Demand Client Cache

the **activate** command in Talk 6 or via the Talk 5 feature HOD Client Cache. The exception to this is if the cluster/port for an HTTP Proxy is removed via Talk 6 feature NDR it will cause the HTTP proxy for the Host On-Demand Client Cache to also be removed from the current running configuration.

### Example:

```
Config>f ndr
NDR Config>enable executor
NDR Config>add cluster
Cluster Address [0.0.0.0]? 113.3.1.10
FIN count [4000]?
FIN time out [30]?
Stale timer [1500]?
Cluster 113.3.1.10 has been added.
Fincount has been set to 4000 for cluster 113.3.1.10
Fintimeout has been set to 30 for cluster 113.3.1.10
Staletimer has been set to 1500 for cluster 113.3.1.10
NDR Config>add port
Cluster Address [0.0.0.0]? 113.3.1.10
Port number [80]? 80
Port type(tcp=1, udp=2, both=3) [3]?
Max. weight (0-100) [20]?
Only one pftp port per cluster allowed
Port mode (none=0, sticky=1 pftp=2 extcache=4 hod client cache=5) [0]? 5
Default server TCP connection timeout (Range 5-240 seconds) [120]?
Default client TCP connection timeout (Range 5-240 seconds) [120]?
Maximum partition size (1-4095 megabytes or 0 for no limit) [0]?
URL mask to identify Java applet [*.jar]?
    Default expiration time for Java applet
        (1-10080 minutes or 0 for no expiration) [60]?
Do you want to add a URL mask? [No]:

The Host On-Demand Client Cache partition has been successfully created.
Requested port has been added to cluster 113.3.1.10
Port Mode has been set to hod for port 80 in cluster 113.3.1.10
Maxweight has been set to 20 for port 80 in cluster 113.3.1.10
Port Type has been set to Both for port 80 in cluster 113.3.1.10
NDR Config>exit
```

**Note:** This example is partial and only shows the adding of the HOD Client Cache port (80) with its unique port mode and console menu. The remainder of the configuration follows examples seen in “Chapter 8. Using the Network Dispatcher Feature” on page 95.

The following lists the example parameters and their descriptions.

#### cluster-address

Specifies the IP address for the cluster.

**Note:** Cluster IP Addresses are assumed to be on the same logical subnet as the previous hop router (IP router).

**Valid values:** Any valid IP address

**Default value:** 0.0.0.0

#### FIN-count

Specifies the number of connections that must be in FIN state before the executor tries to remove the unused connection information from the Network Dispatcher database after *FIN-timeout* or *Stale-timer* has elapsed.

**Valid Values:** 0 to 65535

**Default value:** 4000

#### FIN-timeout

Specifies the number of seconds, that a connection has been in the FIN state, after which the executor tries to remove the unused connection information from the Network Dispatcher database.

## Configuring and Monitoring Host On-Demand Client Cache

	<b>Valid Values:</b> 0 to 65535 <b>Default value:</b> 30
<b>Stale-timer</b>	Specifies the number of seconds, that a connection has been inactive, after which the executor tries to remove a connection's information from the Network Dispatcher database. <b>Valid Values:</b> 0 to 65535 <b>Default value:</b> 1500
<b>port#</b>	Specifies the port number of the protocol for this cluster. <b>Valid Values:</b> 1 to 65535 <b>Default value:</b> 80
<b>port-type</b>	Specifies the types of IP traffic that can be load balanced on this port. Supported types are: <ul style="list-style-type: none"><li>• 1 = TCP</li><li>• 2 = UDP</li><li>• 3 = both</li></ul> <b>Valid Values:</b> 1, 2, 3 <b>Default value:</b> 3
<b>max-weight</b>	Specifies the maximum weight for servers on this port. This affects how much difference there can be between the number of requests the executor will give each server. <b>Valid Values:</b> 0 to 100 <b>Default value:</b> 20
<b>port-mode</b>	Specifies whether the port will feed all requests from a single client to a single server (known as sticky), use passive ftp (pftp), feed an external scalable cache array (extcache), use Host On-Demand Client Cache or use no particular protocols on this cluster (none). <b>Valid Values:</b> 0,1,2,4,5, where: <ul style="list-style-type: none"><li>• 0 = none</li><li>• 1 = sticky</li><li>• 2 = pftp</li><li>• 4 = extcache</li><li>• 5 = hod client cache</li></ul> <b>Default value:</b> 0
<b>Default server TCP connection timeout</b>	Specifies the time before a server connection expires. <b>Valid Values:</b> 5 to 240 seconds <b>Default Value:</b> 120 seconds
<b>Default client TCP connection timeout</b>	Specifies the time before a client connection expires. <b>Valid Values:</b> 5 to 240 seconds <b>Default Value:</b> 120 seconds

## Configuring and Monitoring Host On-Demand Client Cache

### Do you want to modify the Host On-Demand Client Cache partition?

Allows you to modify the configuration of the Host On-Demand Client Cache partition.

**Valid Values:** Yes or No

**Default Value:** No

### Maximum partition size

Specifies the maximum amount of memory to be allocated to this Host On-Demand Client Cache partition. If this value exceeds the amount of memory currently available, it will be ignored and no maximum partition size will be imposed.

**Valid Values:** 1 to 4095 Megabytes or 0 (no maximum)

**Default Value:** 0 (no maximum)

### URL mask to identify Java applets

Specifies the URL mask used to identify Java applets.

**Valid Values:** any URL mask

**Default Value:** \*.jar\*

### Default expiration time for Java applet

Specifies the default expiration time that will apply to Java applets.

**Valid Values:** 1 - 10080 minutes, or 0 for no expiration

**Default Value:** 60

### Do you want to add a URL mask?

Specifies a new URL mask to be added to the Host On-Demand Client Cache. URL masks allow the user to include or exclude individual objects or groups of objects by their Universal Resource Locator (URL).

**Note:** This feature is not normally used with Host On-Demand, but it is explained here for completeness. There is one URL mask which is of interest; it is the Java applet mask which is configured as part of the partition. That mask is typically the only one which should be configured; thus it is recommended you do not use the add, delete, list, modify urlmask commands.

**Valid Values:** Yes or No

**Default Value:** No

Wildcard characters can be used when specifying a URL mask. Wildcards can be used when configuring Network Dispatcher for Host On-Demand Client Cache or when using the **add** or **modify url** command from the HOD Client Cache prompt. The characters used as wildcards are an \* (asterisk) or a # (number sign). Wildcards can be used in any position as a part of the URL.

The \* represents no characters or all characters as a part of that URL:

**Example:** \*abc.html would filter the following URL masks.

```
abc.html  
finabc.html  
defchtjqsprabc.html
```

## Configuring and Monitoring Host On-Demand Client Cache

The # represents any single character.

**Example:** ab#.html would filter the follow URL masks.

```
abc.html  
abf.html  
abo.html
```

You must use Network Dispatcher to configure the initial cluster and port for the Host On-Demand Client Cache feature. Once you have added the cluster and port, configuring the *port mode* as a Host On-Demand Client Cache port, you can then modify and display Host On-Demand Client Cache configuration parameters at the HOD Client Cache Config> prompt.

See on page 118 for information about Network Dispatcher.

---

## Accessing the Host On-Demand Client Cache Configuration Environment

To access the Host On-Demand Client Cache configuration environment, enter the **hod client cache** command at the Config> prompt.

```
Config> f h  
HOD Client Cache Config>
```

---

## Host On-Demand Client Cache Commands

This section describes the Host On-Demand Client Cache Configuration commands. Table 16 lists the Host On-Demand Client Cache configuration commands. These commands specify the Host On-Demand Client Cache feature parameters. To activate these changes, restart the router or use the **activate** command.

*Table 16. Host On-Demand Client Cache Configuration Commands Summary*

Command	Function
? (Help)	Displays all the commands available for this command level or lists the options for specific commands (if available). See “Getting Help” on page xxxii.
Activate	Activates the Host On-Demand Client Cache partition, using the latest configuration.
Add	Adds a URL mask.
Delete	Deletes a URL mask or a partition.
List	Lists the Host On-Demand Client Cache information.
Modify	Modifies the Host On-Demand Client Cache information.
Exit	Returns you to the previous command level. See “Exiting a Lower Level Environment” on page xxxii.

## Activate

Use the **activate** command to initialize the Host On-Demand Client Cache partition, using the latest configuration.

**Syntax:**  
**activate**

**Example:**

```
HOD Client Cache Config>act ?  
ACTIVATE ALL initializes the Host On-Demand Client Cache partition, using  
the latest configuration.
```

## Configuring and Monitoring Host On-Demand Client Cache

### Add

Use the **add** command to add a URL mask.

**Note:** This feature is not normally used with Host On-Demand..

**Syntax:**

**add** urlmask

**Note:** To add proxies and the partition, you must use Network Dispatcher and go through the **add port** or **set port** commands.

### Delete

Use the **delete** command to delete a URL mask or the partition.

**Syntax:**

**delete** partition  
urlmask

**partition**

Deletes the Host On-Demand Client Cache partition.

**urlmask**

The name of the URL mask to be deleted from the Host On-Demand Client Cache.

**Note:** URL masks are not normally added or deleted with HOD Client Cache.

**Example:**

```
HOD Client Cache Config>del part
The HOD Client Cache partition number has been deleted.
```

**Note:** To delete a proxy you must use the Network Dispatcher feature and remove the associated port and/or cluster, or change the port mode of the port to something other than Host On-Demand Client Cache.

### List

Use the **list** command to list the Host On-Demand Client Cache information.

**Syntax:**

**list** all  
external  
partition  
proxy  
urlmask

**all** Lists the partition, all the ports, proxies and masks defined in a Host On-Demand Client Cache.

**external**

Lists the information for the External Cache Control Manager.

**Note:** The ECCM is typically not used with Host On-Demand Client Cache.

**partition**

Lists the Host On-Demand Client Cache partition.

**proxy**

Lists the Host On-Demand Client Cache proxies.

## Configuring and Monitoring Host On-Demand Client Cache

### urlmask

Lists the defined Host On-Demand Client Cache URL masks.

#### Example: list all

```
HOD Client Cache Config>list all
Host On-Demand Client Cache Partition
  Cluster address 113.3.1.10, Port 80

1 Host On-Demand Client Cache partition defined.
```

#### Example: list partition

```
HOD Client Cache Config>list pa
Host On-Demand Client Cache Partition
Maximum partition size      : Unlimited
URL mask to identify Java applets: '*.jar'
  Default expiration time for Java applet: 60
Associated proxies (cluster port): (113.3.1.10 80)

1 Host On-Demand Client Cache partition defined.
```

#### Example: list proxy

```
HOD Client Cache Config>li pro
  1) Cluster address 113.3.1.10, Port 80, HOD Client Cache partition
HTTP proxy number [1]? 1
HTTP Proxy 1
HOD Client Cache Partition
Cluster Address      : 113.3.1.10
Port Number         : 80
Server Connection Timeout : 120 seconds
Client Connection Timeout : 120 seconds
```

## Modify

Use the **modify** command to modify the Host On-Demand Client Cache configuration information.

### Syntax:

```
modify          external
                  partition
                  proxy
                  urlmask
```

### external

Changes the characteristics of the External Cache Control Manager.

**Note:** This feature is not normally used with Host On-Demand..

### partition

Changes the characteristics of the existing Host On-Demand Client Cache partition.

**proxy** Changes the characteristics of an existing HTTP proxy.

### urlmask

Changes an existing URL mask.

**Note:** This feature is not normally used with Host On-Demand..

#### Example: modify partition

```
HOD Client Cache Config>modify partition
Maximum partition size (1-4095 megabytes or 0 for no limit) [0]? 2000
URL mask to identify Java applet [*.jar]?
```



## Configuring and Monitoring Host On-Demand Client Cache

Default expiration time for Java applet  
(1-10080 minutes or 0 for no expiration) [60]?  
The Host On-Demand Client Cache partition has been modified.

### Example: modify proxy

```
HOD Client Cache Config>mod proxy
  1) Cluster address 113.3.1.10, Port 80, HOD Client Cache partition
HTTP proxy number [1]? 1
Default server TCP connection timeout (Range 5-240 seconds) [120]? 200
Default client TCP connection timeout (Range 5-240 seconds) [120]?
The HTTP proxy has been modified.
```

---

## Accessing the Host On-Demand Client Cache Monitoring Environment

To access the Host On-Demand Client Cache monitoring environment enter the **f h** command at the t 5 config prompt.

+f h

---

## Host On-Demand Client Cache Monitoring Commands

Table 17 lists the Host On-Demand Client Cache monitoring commands.

Table 17. Host On-Demand Client Cache Monitoring Commands Summary

Command	Function
? (Help)	Displays all the commands available for this command level or lists the options for specific commands (if available). See "Getting Help" on page xxxii.
Activate	Activates the Host On-Demand Client Cache information, using the latest configuration.
Clear	Clears all objects from the Host On-Demand Client Cache partition or clears Host On-Demand Client Cache statistics.
Enable	Enables the Host On-Demand Client Cache partition.
Delete	Deletes the Host On-Demand Client Cache partition, proxy or URL mask.
Disable	Disables the Host On-Demand Client Cache partition.
List	Lists the Host On-Demand Client Cache information.
Modify	Modifies the Host On-Demand Client Cache information.
Exit	Returns you to the previous command level. See "Exiting a Lower Level Environment" on page xxxii.

### Activate

Use the **activate** command to activate the Host On-Demand Client Cache partition or proxies, or a specific proxy.

#### Syntax:

```
activate all
          external
          partition
          proxy
```

**all** Activates the Host On-Demand Client Cache partition, all the defined proxies and the defined External Cache Control Manager.

**external**  
Activates the External Cache Control Manager.

**partition**  
Activates the Host On-Demand Client Cache partition.

**proxy** Activates a Host On-Demand Client Cache proxy.

## Configuring and Monitoring Host On-Demand Client Cache

**Example:** activate all

```
HOD Client Cache>act all
The Host On-Demand Client Cache partition must be disabled to reactivate it.
Do you wish to continue? [No]: y
```

**Example:** activate partition

```
HOD Client Cache>act pa
The Host On-Demand Client Cache partition must be disabled to reactivate it.
Do you wish to continue? [No]: y
Do you wish clear this partition? [No]: y
Do you wish to enable this partition? [Yes]: y
```

**Example:** activate proxy

```
HOD Client Cache>activate pr
1) Cluster address 113.3.1.10, Port 80, HOD Client Cache partition
Enter proxy number: [1]? 1
You are trying to activate an existing proxy.
Doing this will cause the proxy to be terminated before
being reactivated.
Do you wish to continue? [No]: y
```

## Clear

Use the **clear** command to clear all objects from the Host On-Demand Client Cache partition or to clear statistics.

**Note:** Clearing the objects from the partition does not clear the statistics for the partition.

**Syntax:**

```
clear                partition
                        statistics
```

**partition**

Clears all the objects out of the partition.

**statistics**

Clears existing statistics for the partition.

**Example:** clear partition

```
HOD Client Cache>clear pa
HOD Client Cache partition must be disabled to clear its contents.
Do you wish to continue? [No]: y
Do you wish to enable this partition? [Yes]: y
```

## Enable

Use the **enable** command to enable the Host On-Demand Client Cache partition.

**Syntax:**

```
enable                partition
```

**Example:**

```
HOD Client Cache>enable partition
```

## Delete

Use the **delete** command to delete the Host On-Demand Client Cache partition.

**Syntax:**

```
delete                partition
```

## Configuring and Monitoring Host On-Demand Client Cache

### partition

Deletes the Host On-Demand Client Cache partition.

**Example:** delete partition

```
HOD Client Cache>delete partition
WARNING: This will delete partition and free all memory!
Do you wish to continue? [No] : yes
HOD Client Cache>
```

## Disable

Use the **disable** command to disable the Host On-Demand Client Cache partition.

**Syntax:**

**disable** partition

**Example:**

```
HOD Client Cache>disable partition
```

## List

Use the **list** command to display the information for the Host On-Demand Client Cache partition, all policies and proxies, or a specified policy or proxy.

**Syntax:**

**list** all  
delete  
depend  
external  
item  
partition  
policy  
proxy

**all** Lists the Host On-Demand Client Cache partition, all policies, and all proxies.

**delete** Lists the last 100 items deleted from the Host On-Demand Client Cache partition.

**depend** Lists the dependency table for the partition.

**external** Lists the information for the External Cache Control Manager.

**item** Lists the current items in the Host On-Demand Client Cache partition.

**partition** List the Host On-Demand Client Cache partition information.

**policy** Lists the Host On-Demand Client Cache policy information.

**proxy** Lists the Host On-Demand Client Cache proxy information.

**Example:** list all

```
HOD Client Cache>list all
HOD Client Cache Partition      Status: Enabled
Cluster address: 113.3.1.10 Port 80
1 partition(s) active.
External Cache Manager Port: 83
Connection timeout: 120 seconds
```

## Configuring and Monitoring Host On-Demand Client Cache

### Example: list delete

```
HOD Client Cache>list delete
```

```
Delete Table
URL string -- hit count
=====
'/abc.html' -- 4
'/soccer.html' -- 2
'/tennis.html' -- 1
'/curling.html' -- 3
```

### Example: list item

```
HOD Client Cache>list item
```

```
Current number of items: 5
URL String -- hit count
=====
'/' -- 2
'/file5k.html' -- 1
'/file4k.html' -- 1
'/file2k.html' -- 3
'/file1k.html' -- 1
```

### Example: list partition

```
HOD Client Cache>list partition
HOD Client Cache Partition          Status: Enabled
      Cluster address: 113.3.1.10, Port 80
Partition size: Current - 0 bytes Highest - 0 bytes Maximum - Unlimited
Number of objects: Current - 0 Highest - 0 Maximum - Unlimited
Maximum object size: Unlimited
HOD Client Cache purge interval: 600 minute(s)
Hit ratio: 0%
Total number of hits: 0
Cache Hit Bytes Served: 0
Breakdown of responses for the Cache Hits
(note: this is based on whether the HTTP Proxy considered it a hit.
So these count may not add up to the hit count above)
  Response 200(OK): 0
  Response 203(Non-Authoriative): 0
  Response 206(Partial Content): 0
  Response 300(Multiple Choices): 0
  Response 301(Moved Permanently): 0
  Response 304(Not Modified): 0
  Response 410(Gone): 0
Total number of misses: 0
Cache Miss Bytes Served: 0
Breakdown of responses for the Cache Misses
  Response 100 Range(Information): 0
  Response 200(OK): 0
  Response 200 Range(Successful-not 200): 0
  Response 304(Not Modified): 0
  Response 300 Range(Redirection-not 304): 0
  Response 400 Range(Client Error): 0
  Response 500 Range(Server Error): 0
  Response other (not in the above): 0
Object Excluded (Object too large): 0
                  (Object expired): 0
                  (DONT CACHE header): 0
                  (URL Mask excluded): 0
                  (Image excluded): 0
                  (Static object excluded): 0
                  (Dynamic object excluded): 0
                  (Cache disabled): 0
Total number of objects added via ECCM Interface: 0
Total number of objects not added via ECCM Interface but was attempted: 0
Total number of objects replaced via ECCM Interface: 0
```

### Example: list policy

```
HOD Client Cache>list policy
URL mask to identify Java Applets: *.jar
Default lifetime: 60 minute(s)
```

### Example: list proxy

## Configuring and Monitoring Host On-Demand Client Cache

```
HOD Client Cache>list proxy
  1) Cluster address 113.3.1.10, Port 80, HOD Client Cache Partition
Enter proxy number: [1]? 1
Proxy 1: assigned to the HOD Client Cache partition
Cluster address: 113.3.1.10    Port number: 80
Server Connection Timeout: 120 seconds
Client Connection Timeout: 120 seconds
Client connections: 0 current / 0 at highest point
Server connections: 0 current / 0 at highest point
Total cache hits: 0
Total cache misses: 0
Cache misses (object not in cache): 0
              (unsupported method): 0
              (can't send response): 0
              (non-cached request): 0
```

### Modify

Use the **modify** command to modify the External Cache Control Manager.

**Syntax:**  
**modify** external

---

## Host On-Demand Client Cache Dynamic Reconfiguration Support

This section describes dynamic reconfiguration (DR) as it affects Talk 6 and Talk 5 commands.

### CONFIG (Talk 6) Delete Interface

Host On-Demand Client Cache does not support the CONFIG (Talk 6) **delete interface** command.

### GWCON (Talk 5) Activate Interface

The GWCON (Talk 5) **activate interface** command is not applicable for Host On-Demand Client Cache. The Host On-Demand Client Cache is a feature, not an interface.

### GWCON (Talk 5) Reset Interface

The GWCON (Talk 5) **reset interface** command is not applicable for Host On-Demand Client Cache. The Host On-Demand Client Cache is a feature, not an interface.

### GWCON (Talk 5) Component Reset Commands

Host On-Demand Client Cache (HOD) supports the following Host On-Demand Client Cache (HOD)-specific GWCON (Talk 5) **reset** commands:

#### GWCON, Feature HOD, Activate All Command

##### Description:

This command will read all of the SRAMs for Host On-Demand Client Cache and make the current run time environment the same.

##### Network Effect:

All proxies that were currently active will be terminated (that is, all connections on those proxies will be brought down). If the External Cache Control Manager was running, the device will stop listening for new connections on the current port (that is, the connections to the current port will not go down).

## Configuring and Monitoring Host On-Demand Client Cache

### Limitations:

There are no limitations.

All Host On-Demand Client Cache commands are supported by the **GWCON, feature HOD, activate all** command.

### GWCON, Feature HOD, Activate Partition Command

#### Description:

This command will read all of the SRAMs for this partition and make the current run time environment for the partition be the same.

#### Network Effect:

If the partition being activated already exists, all the proxies on that partition will be terminated (that is, all connections on those proxies will be brought down).

#### Limitation:

The Host On-Demand Client Cache must already have been activated (see **CONFIG, feature HOD, activate**).

The following table summarizes the Host On-Demand Client Cache configuration changes that are activated when the **GWCON, feature HOD, activate partition** command is invoked:

Commands whose changes are activated by the <b>GWCON, feature HOD, activate partition</b> command
CONFIG, feature HOD, add URLMASK
CONFIG, feature HOD, delete PARTITION
CONFIG, feature HOD, delete URLMASK
CONFIG, feature HOD, modify PARTITION
CONFIG, feature HOD, modify PROXY
CONFIG, feature HOD, modify URLMASK

### GWCON, Feature HOD, Activate Proxy Command

#### Description:

This command will read all of the SRAMs for this proxy and make the current run time environment for the proxy be the same.

#### Network Effect:

If the proxy being activated already exists, it will be terminated first (that is, all the connections on the proxy will be brought down).

#### Limitations:

- The Host On-Demand Client Cache must have already been activated (see **CONFIG, feature HOD, activate**).

The following table summarizes the Host On-Demand Client Cache configuration changes that are activated when the **GWCON, feature HOD, activate proxy** command is invoked:

Commands whose changes are activated by the <b>GWCON, feature HOD, activate proxy</b> command
CONFIG, feature HOD, modify PROXY

## Configuring and Monitoring Host On-Demand Client Cache

### GWCON, Feature HOD, Activate External Port Command

#### Description:

This command will read all of the SRAMs for the External Cache Control Manager and make the current run time environment for the External Cache Control Manager be the same.

#### Network Effect:

If the External Cache Control Manager was running, the device will stop listening for new connections on the current port (that is, the connections to the current port will not go down).

#### Limitations:

- The Host On-Demand Client Cache must have already been activated (see **CONFIG, feature HOD, activate** command).

The following table summarizes the Host On-Demand Client Cache (HOD) configuration changes that are not activated when the **GWCON, feature HOD, activate external port** command is invoked:

Commands whose changes are activated by the <b>GWCON, feature HOD, activate external port</b> command
---

CONFIG, feature HOD, modify EXTERNAL
--------------------------------------

## CONFIG (Talk 6) Activate Commands

Host On-Demand Client Cache (HOD) supports the following CONFIG (Talk 6) **activate** commands:

### CONFIG, Feature HOD, Activate Command

#### Description:

Dynamically changes the Host On-Demand Client Cache currently running based on the current SRAM.

#### Network Effect:

All proxies that were currently active will be terminated (that is, all connections on those proxies will be brought down). If the External Cache Control Manager was running, the device will stop listening for new connections on the current port (that is, the connections to the current port will not go down).

#### Limitations:

None

All Host On-Demand Client Cache commands are supported by the **CONFIG, feature HOD, activate** command.

## GWCON (Talk 5) Temporary Change Commands

Host On-Demand Client Cache (HOD) supports the following GWCON commands that temporarily change the operational state of the device. These changes are lost whenever the device is reloaded, restarted, or you execute any dynamically reconfigurable command.

Commands
----------

## Configuring and Monitoring Host On-Demand Client Cache

GWCON, feature HOD, modify external

**Note:** This command will change the current run time environment for the External Cache Control Manager. If the External Cache Control Manager was running, the device will stop listening for new connections on the current port (that is, the connections to the current port will not go down).

GWCON, feature HOD, delete partition

**Note:** This command will delete the partition from the current run time environment.



## Chapter 11. Using Web Server Cache

This chapter describes the 2212 Web Server Cache feature. It contains the following:

- “Web Server Cache Overview”
- “Using the HTTP Proxy” on page 163
- “Scalable High Availability Cache” on page 164
- “External Cache Control Manager Overview” on page 168.

### Web Server Cache Overview

Web Server Caching is only available for 2212 models with the High Performance System Card. You can upgrade 2212 models without the High Performance System Card. Contact your IBM Service representative for more information.

Web Server Caching stores frequently requested Web pages for quick retrieval. Web Server Caching keeps frequently requested items closer to the clients; this frees up server resources currently being used for file serving and communication connections. The 2212 Web Server Cache provides high-speed access to Web pages while reducing host communications overhead. The 2212 Web Server Cache:

- Stores the static, unprotected Web pages
- Provides the HTTP clients and servers with access to the cache
- Allows the user definition of cache population and invalidation policies
- Uses the Network Dispatcher function to perform workload balancing among servers and provide backup cache capabilities
- Provides a platform for future server-directed caching functions.

**Note:** The Web Server Cache and the Host On-Demand Client Cache feature cannot co-exist in a configuration.

All 2212 network interfaces that support TCP/IP connectivity, support connectivity between Web Server Cache, HTTP servers, and clients.

Figure 10 shows how Network Dispatcher works without Web Server Caching.

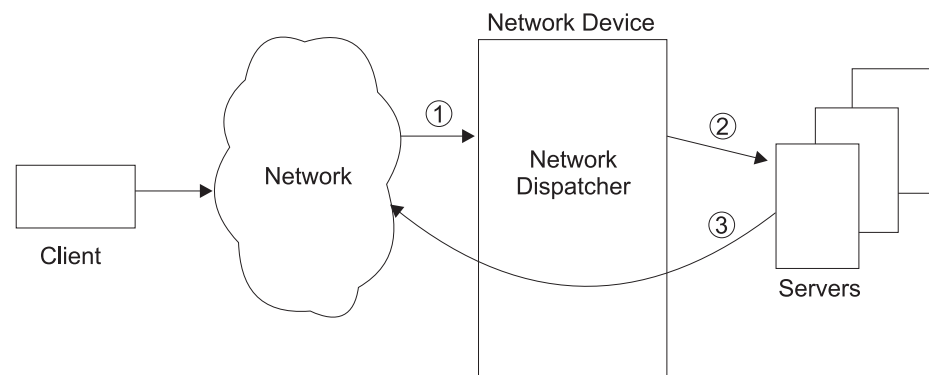

Figure 10. Network Dispatcher without Web Server Cache

1. Request comes for cluster address
2. Network Dispatcher forwards a request to servers
3. Server sends response back to client.

## Using Web Server Cache

Figure 11 shows how Network Dispatcher works with Web Server Caching and the requested page is not currently cached. Web Server Caching loads the response into the cache if the policies allow it.

See “Using the HTTP Proxy” on page 163 for information about HTTP Proxy.

A partition is a division of the cache core memory. Each cache partition is configured independently and allows the device to support multiple sites.

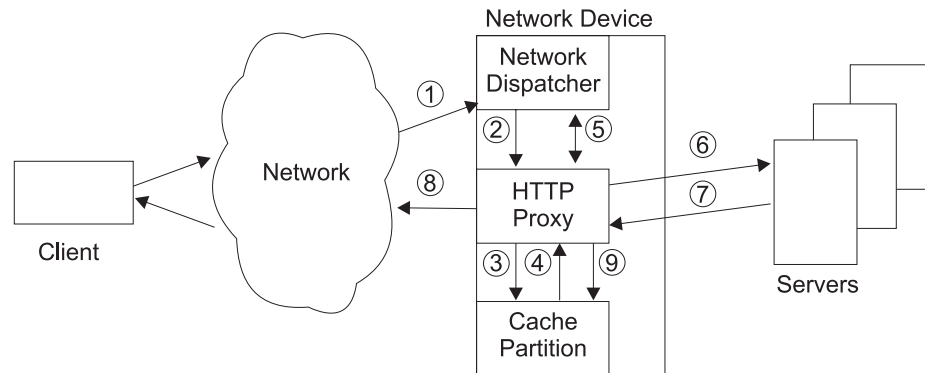

Figure 11. Network Dispatcher with Web Server Cache and No Cache Hit

1. Request comes to cluster address
2. Network Dispatcher forwards the request to HTTP Proxy if the partition is enabled.
3. HTTP Proxy looks in the cache partition
4. HTTP Proxy does not find the requested page in the cache partition
5. HTTP Proxy gets server information from Network Dispatcher if required for new connection
6. HTTP Proxy forwards the request to the server. (For the TCP connection the source IP address is the address of the 2212 network interface. The destination IP address is the server interface IP address.)
7. Server sends response back to HTTP Proxy
8. HTTP Proxy sends the response to client
9. HTTP Proxy loads the response into cache partition if the policies allow it.

It is important that the administrator realize that the destination address for packets destined to the server is the server address and not the cluster address, as stated in step 6 above. The issue is important when a Web server is configured on a host: if the Web server is configured to listen on a specific IP address, that IP address must be the server interface IP address. More generally, the server interface will have a set of logical IP addresses assigned to it. When the Network Dispatcher cluster is configured to use a server logical IP address, the corresponding Web server must be configured to listen on that logical IP address. Hence, one host (server) may have several Web servers, each listening on a different logical IP address. Network Dispatcher can be configured with separate clusters for each Web server. In this way, one host can be used for a number of Web sites. Also a separate cache partition needs to be used for each Web Server. When the Web Servers are on replicated hosts, multiply the number of replicated hosts times the number of Web Servers to determine the number of server addresses used.

In addition, the number of cluster addresses should be aliased on each host's loopback address; then if a cache partition is disabled, the Web Server will continue

to be reachable, as the Network Dispatcher falls back to simple port mode zero (no caching). The fallback operation is guaranteed only for direct attached servers; otherwise, routing might be unwieldy or impossible.

Figure 12 shows how Network Dispatcher works with Web Server Caching when the requested page is currently cached.

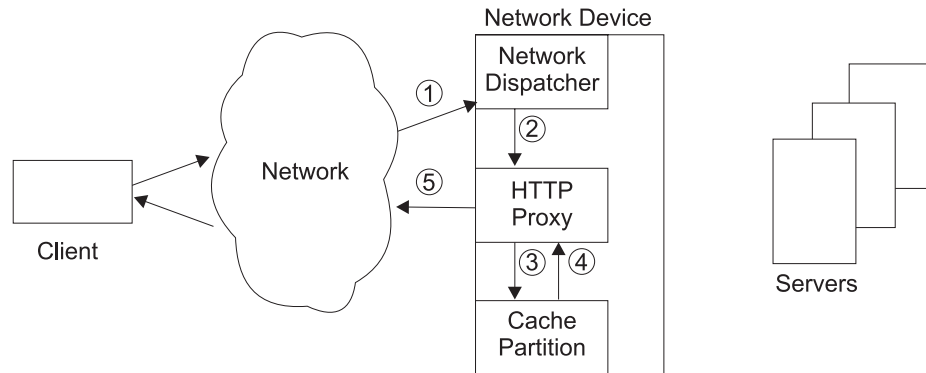

Figure 12. Network Dispatcher with Web Server Cache and Cache Hit

1. Request comes for cluster address
2. Network Dispatcher forwards request to HTTP Proxy
3. HTTP Proxy looks in the cache partition
4. HTTP Proxy finds the requested page in the cache partition
5. HTTP Proxy returns response to the client.

## Caching

The 2212 Web Server Cache has:

### Caching of Web pages

The 2212 can cache objects that are requested from the server. This caching is called transparent caching. You can use `talk 6` to enable or disable transparent caching for a partition.

The alternative to transparent (automatic) caching is manual caching. In this case, an external agent uses the cache manager to cache a Web page. For information about externally controlled Web caching see “External Cache Control Manager Overview” on page 168.

Stale cached objects are automatically deleted. The 2212 Web Server Cache supports both HTTP 1.0 and 1.1 servers and clients.

### Flexible cache policies

Allows users to specify whether certain broad classes of Web objects (images, non-image-static pages, dynamic pages) are to be cached. You can also specify maximum sizes for objects and cache partitions. In addition, users may specify URL masks to explicitly include or exclude classes of Web objects as appropriate to their environment.

### Flow chart for transparent caching policies:

1. Is caching enabled and transparent caching enabled?
  - No - The object is not cached.

## Using Web Server Cache

- Yes - Go to step 2
2. Is the object size within the maximum object size?
    - No - The object is not cached.
    - Yes - Go to step 3
  3. Has the object expired?
    - No - Go to step 4
    - Yes - The object is not cached.
  4. Are HTTP headers to be used, and was one of the HTTP headers used? **The HTTP header used is a Cache-Control header with either the DO or DONT directives.**
    - 
    - Yes - Are HTTP headers used, and does the object include a cache control header? Go to step 5.
  5. Do the HTTP headers indicate "DO" cache?
    - No - The object is not cached.
    - Yes - Go to step 9.
  6. Is the URL excluded by an exclude mask?
    - Yes - The object is not cached.
    - No - Go to step 7
  7. Is the URL included via an include mask?
    - Yes - Go to step 9.
    - No - Go to step 8
  8. Is the object an image (.jpg or .gif)?
    - No - Go to step 9.
    - Yes - Are images cachable?
      - Yes - Go to step 11.
      - No - The object is not cached.
  9. Is the object a static non-image?
    - No - Got to step 10.
    - Yes - Are static non-images cachable?
      - Yes - Go to step 11.
      - No - The object is not cached.
  10. The object is a dynamic object. Are dynamic objects cachable?
    - Yes - Go to step 11.
    - No - The object is not cached.
  11. Is there room in the partition for the object? **The least recently used objects will be removed in order to try to make room for the object.**
    - No - The object not cached.
    - Yes - The object is cached.

### Support of multiple independent caches

Supports up to 16 partitions, allowing a single 2212 to provide independent cache services for multiple clusters. Cache partitions are fully independent. Each cache partition maintains its own contents and policies.

### Full TCP/IP server connectivity

Communicates with both servers and clients across all 2212 network interfaces which support the TCP/IP protocol suite.

### Load balancing to back-end servers (by way of Network Dispatcher)

Uses Network Dispatcher to define groups of servers and balance load between servers to speed lookup of Web pages not found in the cache.

### Backup cache support

Allows users to define a second 2212 as a backup server cache. The backup server cache can operate as a "cold" backup using the Network Dispatcher High Availability function, See "High Availability for Network Dispatcher" on page 97 for more information.

**Note:** The backup server cache comes up empty. You must repopulate the backup server cache by using either transparent caching (For example: requests for URLs) or by using the external cache control manager function to force pages into the cache.

---

## Using the HTTP Proxy

Each HTTP Proxy represents a cluster address/port that is doing caching. There can be multiple HTTP proxies that uses a cache partition.

The HTTP Proxy handles receiving requests from clients and tries to satisfy them from its cache partition. If the HTTP Proxy can satisfy the request, it responds back to the client. If the HTTP Proxy cannot satisfy the request, it opens a TCP connection with a server in an attempt to satisfy the request. When the server responds to the HTTP Proxy's request, the HTTP forwards the server's response to the client. The HTTP Proxy also sees if the response from the client should be cached. If the response should be cached, the HTTP Proxy passes it to the cache partition.

HTTP Proxy handles connections using the following guidelines.

- The HTTP Proxy will only try to meet GET and HEAD method requests from the cache. All other requests will be sent to the server unchanged over a TCP connection to the server that is paired with the TCP connection from the client. If there is not a TCP connection paired with the TCP connection from the client, a new TCP connection will be opened to the server and paired with the TCP connection to the client.
- All GET and HEAD method requests that can not be met from the cache partition will have their messages sent to the server unchanged over the TCP connection.
- All responses will be sent back to the client over TCP connection to the client unchanged from what the server sent.
- Only GET method responses can be cached. All other responses are considered to be not cachable. GET responses are only cached if the status of the response is acceptable and the GET response along with caching policies for the partition allows it to be cached.
  - Only responses with one of the following status codes will be cached. The HTTP Proxy will not allow HTTP headers to overrule this.

#### Status codes:

- 200 (ok)
- 203 (non-authoritative)

## Using Web Server Cache

- 300 (multiple-choice)
- 301 (moved permanently)
- 410 (gone)
- When HTTP headers are used on the GET request only the If-Modified-Since request header will be involved in determining if an entry in the cache can meet that request. All other conditional headers will not be used. The Web Server Cache will not use entity tags to determine whether a cached entity can be used in a response.
- The Cache-Control header directives on the requests are ignored. If the entity is not in the cache partition the request is passed to the server.

**Note:** The Web Server Cache is an extension to the server and therefore does not use the Cache-Control header like HTTP Proxy caches.

- The cache header directives "do", and "dont" are supported on the responses. All other directives are ignored. The "do" and "dont" directives are new directives that can be used by the server to tell the Web Server Cache to cache or not cache the entity.
- The HTTP Proxy attempts to meet partial GET requests from the cache. However, partial GET responses are not cached.

**Note:** If a partial GET request has more than ten ranges, the entire response will be returned.

- The Host header will be ignored on all HTTP messages, since all incoming requests should be for the same server cluster.
- The HTTP Proxy supports persistent HTTP connections.

**Note:** If a persistent connection comes in from an HTTP 1.0 level client and the response is returned from the cache it will append a Connection header based on the request. For example, if the client wants a long-lived connection, it will maintain a long-lived connection.

- The HTTP Proxy will not use the cache for requests that contain the Authorization header. A response to such a request will not be cached. A response with a Proxy-Authorization header will not be cached.
- The HTTP Proxy will be able to switch to tunneling behavior for an HTTP connection if it runs into problems parsing a request or a response on an HTTP connection. Tunneling behavior stops all message parsing and will forward all requests from the client to the server and all responses from the server to the client.
- If the cache partition is disabled, all current and new client connections are forwarded directly to the back-end server. For this feature to work, follow the procedure "Configuring a Server for Network Dispatcher" in "Chapter 8. Using the Network Dispatcher Feature" on page 95.
- If the cache partition is enabled, all new client connections are processed by the cache. Existing client connections continue to forward requests directly to the back-end server.

---

## Scalable High Availability Cache

Scalable High Availability Cache allows a group of connected Web Server Caches to function as one large cache. The maximum number of caches in a group is sixteen. A failure with one cache member reduces the total amount of memory available for caching, rather than end all cache functions. See Figure 17 on page 168 for a configuration example.

## Using Web Server Cache

The individual caches make up the total cache space. If a cache becomes nonfunctional, incoming pages will continue to be cached by the remaining working caches.

Incoming Web pages are stored in the group's caches. They are distributed evenly among the available caches. Each cache in the group maintains a table that tracks the number of reachable caches in the group and their IP addresses. The tables are identical for all caches in a group. The tables are used along with a Cache Array Routine Protocol (CARP) algorithm to determine which cache owns a particular URL. The information for the table comes from the Network Dispatcher device and indirectly from the caches that are using the HTTP advisor to keep track of the status of the Web Server Caches in the group. The following figures demonstrate the conditions for locating a URL using SHAC.

Figure 13 shows the request from Network Dispatcher found in the first cache that received the request.

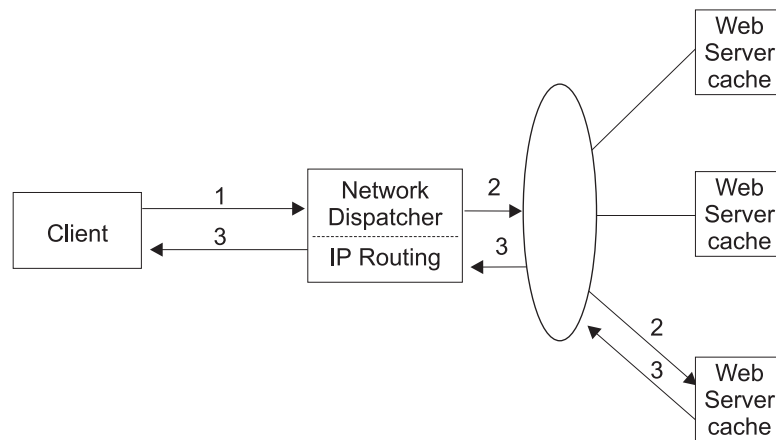

Figure 13. Cache Request Found

1. An HTTP request for a Web page comes from a client to the Network Dispatcher.
2. The request is forwarded by the Network Dispatcher to one of the Web Server Caches. The cache receives the request and finds that it contains the Web page.
3. The cache sends the Web page directly to the client by bypassing Network Dispatcher.

Figure 14 on page 166 shows a request not found in the first cache that received the request from Network Dispatcher and the CARP algorithm indicates that another cache owns the URL.

## Using Web Server Cache

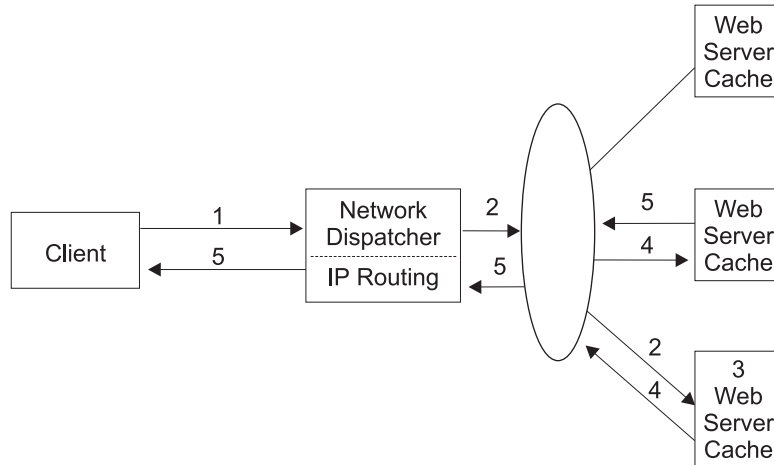

Figure 14. Request Forwarded to the Responsible Cache

1. An HTTP request for a Web page comes from a client to the Network Dispatcher.
2. The request is forwarded by the Network Dispatcher to one of the Web Server Caches.
3. The cache receives the request and does not find the Web page in its cache. The cache then uses an algorithm to locate the cache responsible for the Web page.
4. The request is then forwarded to the cache responsible for that Web page.
5. The cache responsible for the Web page receives the request, finds the Web page and sends the Web page to the client.

Figure 15 shows a request not found in the cache that received the request from Network Dispatcher, but the CARP algorithm indicates that the cache is responsible for the URL.

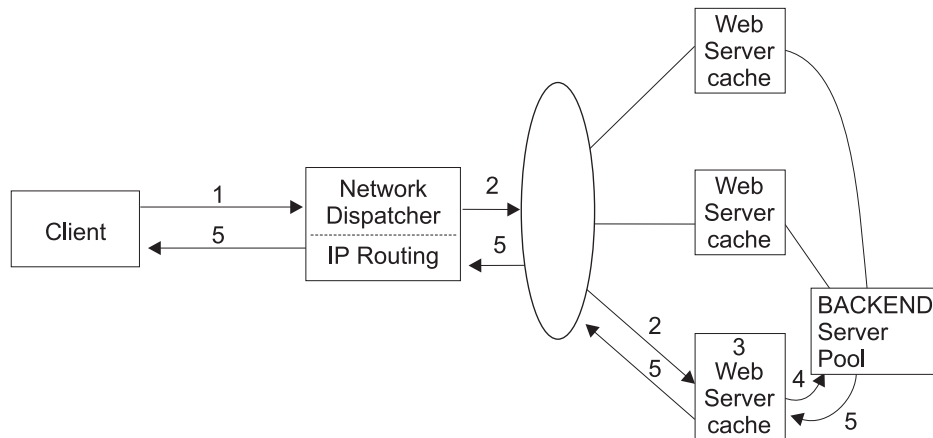

Figure 15. Request Forwarded to Backend Server

1. An HTTP request for a Web page comes from a client to the Network Dispatcher.
2. The request is forwarded by the Network Dispatcher to one of the Web Server Caches.



## Using Web Server Cache

3. The cache receives the request and does not find the Web page in its cache. The cache uses an algorithm to determine that it is responsible for the Web page.
4. The cache sends the request to the backend server.
5. The backend server finds the Web page; that Web page is returned through the cache that is responsible for that Web page to the client. It will be cached if the cache has been configured to cache that page. See “Chapter 12. Configuring and Monitoring Web Server Cache” on page 197 for configuration information.

Figure 16 shows a request that is not found in any cache in the cache group.

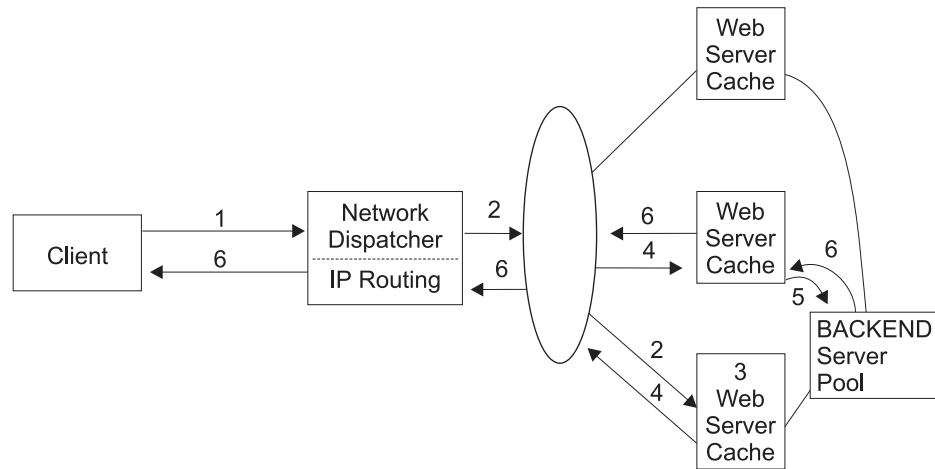

Figure 16. Request Forwarded to the Responsible Cache and Not Found

1. An HTTP request for a Web page comes from a client to the Network Dispatcher.
2. The request is forwarded by the Network Dispatcher to one of the Web Server Caches.
3. The cache receives the request and does not find the Web page in its cache. The cache then uses an algorithm to locate the cache responsible for the Web page. The request is then forwarded to the cache responsible for that Web page.
4. The cache responsible for the Web page receives the request and does not find the Web page.
5. The cache responsible for the Web page sends the request to the backend server pool.
6. The backend server finds the Web page; that Web page is returned through the cache that is responsible for that Web page to the client. It will be cached if the cache has been configured to cache that page. See “Chapter 12. Configuring and Monitoring Web Server Cache” on page 197 for configuration information.

**Note:** In Figure 15 on page 166 and Figure 16, it is to be understood that all caches in the group are to be connected to all backend servers in the pool to achieve maximum reliability.

Figure 17 on page 168 shows a tested example of SHAC with detailed configuration parameters used in conjunction with “Using Network Dispatcher with Scalable High Availability Cache (SHAC)” on page 111, “Chapter 9. Configuring and Monitoring the Network Dispatcher Feature” on page 113 and “Chapter 12. Configuring and

## Using Web Server Cache

Monitoring Web Server Cache” on page 197. The interface addresses, internal addresses, cluster addresses, and the server IP address are shown along with the subnet masks. Also shown are routing commands needed for the caches and the backend server that is connected to the 113 Ring.

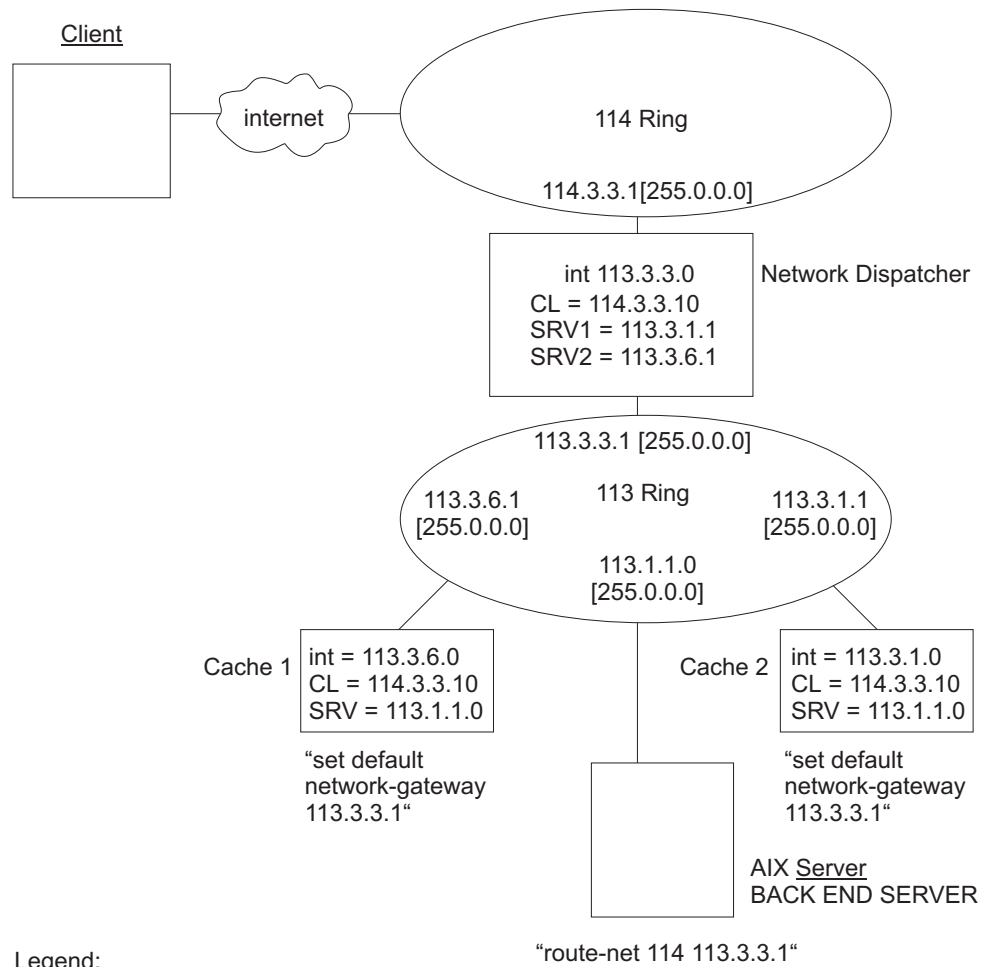

Legend:

- CL: Cluster Address. Note - this example assumes the use of port 80, the default http port.
- INT: Internal address for 22XX router
- SRV: Server address(s) associated with CL
- "...": additional routing commands to establish connectivity.

Figure 17. Two caches with Network Dispatcher, client and backend server

## External Cache Control Manager Overview

The External Cache Control Manager allows Web servers the ability to control the Web Server Cache and the Host-On-Demand Client Cache. This control is by way of a user-defined port for the External Cache Control Manager (ECCM). The ECCM accepts connections and processes commands targeted for a partition over this port. The commands use the External Cache Control Protocol (ECCP). The ECCP uses vector/subvector formats to send request commands and response commands.

One command vector can request multiple functions by having multiple subvectors. Each subvector represents a new function. The command vector indicates to which cache partition the commands are applied by specifying the cluster address and the port of a proxy defined on that partition.

The following functions are supported by ECCP:

- Add/Delete an object to/from a cache partition
- Enable/Disable a cache partition
- Modify/List the policies for a cache partition
- Clear/list the statistics for a cache partition
- Clear a cache partition (remove all the objects from a cache partition)
- Query the cache partition (search for a particular object)
- Add/Delete/List/Clear the URL masks for a cache partition
- Modify/List the dependency table
- Invalidate objects using dependencies.

## Dependency Table

The External Cache Control Manager allows you to create a dependency table for each cache partition. This table is particularly useful when dealing with dynamic objects in the cache.

**Note:** Caching dynamic objects requires that the objects be updated when the information from which these objects were created changes.

The information to build the dependency table must be passed to the cache partition using the External Cache Control Manager interface.

The dependency table gives you the ability to assign a dependency string to a set of URL objects (cached Web pages). These dependencies are stored in dependency tables in the Web Server Cache by using the External Cache Control Manager interface. The dependency table is used to invalidate objects in the cache partition that have this dependency when the source for the object changes. Without a dependency table, you would have to send a separate delete command for each object to be deleted.

**Example:** The following three databases contain various objects.

database1	database2	database3
-----	-----	-----
object_a	object_a	object_b
object_b	object_c	object_e
object_c	object_d	

Assume that all the pages object\_a through object\_e are in the cache. If database2 changes, you can send (via Cache Control Manager interface) an **invalid dependency database2** command. The Web Server Cache will then delete object\_a, object\_c, and object\_d from the cache partition.

**Note:** An object does not need to be in the cache partition to be in the dependency table.

## External Cache Control Manager Authentication

The External Cache Control Manager allows you to control user access. This is accomplished by requiring incoming connections to have a userid and password. The userid and password are tied to the logon userid and password. If the device is password protected and the incoming connection does not have a userid and

## Using Web Server Cache

password or the userid and password are not valid, an authentication error response is returned and the connection is closed. If the userid and password are valid, the user may send commands over that interface.

### Security

Security provides a way to authenticate the ECCP user. Four types of authentication can be configured (RADIUS, TACACS, local, or none). Data encryption is not provided. Each authentication mechanism (except for none) requires both a user ID and associated password. This information is passed to the 2216 using the authentication vectors. The user ID can range from 1-8 bytes, while the password can range from 1-8 bytes. The password passed on the External Cache Control connection must be encrypted using DES encryption. The random 8 byte seed used for the encryption is also passed. The key for the encryption will not be passed over the connection. See “Modify” on page 206 for information about setting the port and TCP values.

**Note:** The Authentication vector will be ignored if the router is not password protected.

## External Cache Control Protocol

The External Cache Control Protocol (ECCP) gives the back-end servers the ability to control the router cache. This control maximizes cache performance.

The ECCP is an architected protocol interface that allows the servers to add and delete objects as well as modify the cache policies.

The external cache control manager is defined in the router (Web Server Cache or Host On-Demand Client Cache) to accept connections and process commands targeted for a cache partition.

### Configuration

The external cache control manager is configured with the following parameters:

#### User-defined port:

The port number where the external cache control manager listens and accepts connections. If 0 is configured, the external cache manager is assumed to be disabled.

**Valid Values:** 0 to 65535

**Default Value:** 0

#### Maximum TCP timeout value:

**Valid Values:** 5 to 240 seconds

**Default Value:** 120

#### Encryption Key:

The Encryption Key will be used if the box is password protected. The Encryption Key must be 16 hex characters (0-9,a-f,A-F).

### External Cache Control Manager Function Descriptions

This section describes the functions of the External Cache Control Manager.

#### Adding an Object

An HTTP response object can be added to the cache partition. The format of the object data must be the same as an HTTP response. The External Cache Control Manager will parse the headers of the response and pull out the information that is needed. Then the object is added to the cache.

The difference between the Add Object and the Add (Force) Object is that the Add (Force) Object will ignore any Cache\_Control headers specifying DO or DONT. All other headers that the HTTP Proxy use to determine whether to cache an object are still used. For both Add Object and Add (Force) Object the object will be replaced in the cache partition regardless of the date.

### Deleting an Object

An HTTP object can be deleted from the cache. The URL for the object is given.

### Using the Dependency Table

The dependency table for a cache partition can be modified, listed, and used to invalidate objects.

When modifying the dependency table (adding or removing dependencies), both the dependency and the dependency URL must be given. In addition, there are two other ways to modify the dependency table. One is to reset the entire table, an entire dependency (i.e. remove the dependency completely), or a URL dependency (i.e. remove the URL dependency from all dependencies). The other is to do a garbage collect on the dependency table. The garbage collect cleans up all the dependency URLs from the dependency table that do not have an object with that URL in the cache.

There are multiple ways of listing the information in the dependency table. The entire table can be retrieved, all the dependency URLs for a given dependency can be retrieved, or all the dependencies that have a give dependency URL can be retrieved.

Objects can be removed (invalidated) from the cache using the Dependency Table. Using the dependency, the Dependency Table is checked. Any dependency URL for that dependency will be removed from the cache partition.

### Disabling/Enabling a Partition

This function allows the cache partition state to be changed. In order to use the External Cache Control Manager the cache partition must be in the correct state. The cache partition must be disabled in order to purge all the objects from it.

### Using Policies

The policies for a partition can be listed or modified. Each policy can be done separately or as a group. When modifying a policy, the correct type of data must be passed for that policy. See “External Cache Control Protocol (ECCP) Vector Formats” on page 172 (Policy Command Subvector and Policy Response Subvector) for the format of the data based on the policy.

### Purging the Partition

This function allows all the objects in the cache partition to be removed. The cache partition must be in the disabled state in order to purge it.

### Querying an Object

This function gives the ability to see if an object is in the cache partition. In addition, if the object is in the cache partition and has a last modified date, that date is returned. See “External Cache Control Protocol (ECCP) Vector Formats” on page 172 (Query Response Subvector) for the format of the date returned.

### Using Statistics

This function gives the ability to list and reset (clear) the cache partition statistics. See “External Cache Control Protocol (ECCP) Vector Formats” on page 172 (Statistics Response Subvector) for the format of the statistics.

## Using Web Server Cache

### Using a URL Mask

This function gives the ability to list and modify the URL masks for a cache partition. The URL type include, exclude, dynamic, or Host On-Demand Client Cache applet must be given when using this function. You must list one URL type. This function does not work with multiple URL types.

You have the ability to add a URL mask. If the URL mask is an include, dynamic, or Host On-Demand Client Cache applet mask the lifetime needs to be given. Adding a dynamic mask will modify the current dynamic URL mask and adding a Host On-Demand Client Cache applet mask will modify the current Host On-Demand Client Cache applet mask. You have the ability to delete a URL mask. This function is not valid for the dynamic URL mask or the Host On-Demand Client Cache applet mask. You have the ability to reset all the URL masks of a peculiar type. Resetting the dynamic URL mask resets to the default dynamic URL mask and resetting the Host On-Demand Client Cache applet mask resets to the default Host On-Demand Client Cache applet mask.

**Note:** The dynamic mask is used with Web Server Cache images and the Host On-Demand Client Cache applet mask is used with images that have the Host On-Demand Client Cache feature.

## External Cache Control Protocol (ECCP) Vector Formats

The ECCP clients sends commands and receives responses using a vector format. The authentication vector is required if the box is password protected. If the box is not password protected the authentication vector is ignored when received.

### Vector Formats

This section describes the field descriptions for the Vectors.

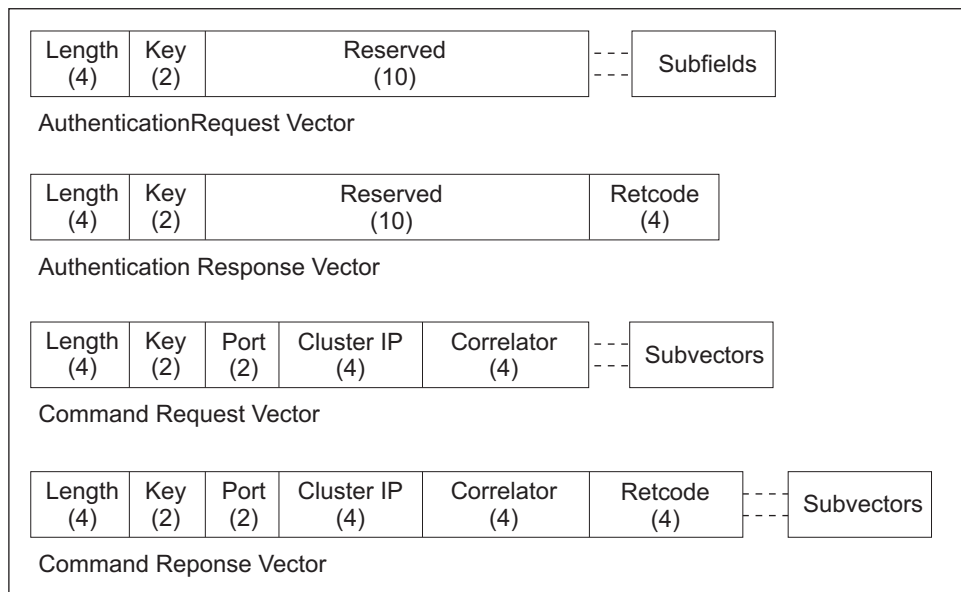

Figure 18. Command Response Vector

**Length:** The unsigned 32-bit value representing the length (in bytes) of the entire vector, including the length and key fields, as well as any subvectors and subfields. The acceptable range is:

- 48 to 56 (Authentication Request Vectors)

- 20 (Authentication Response Vectors)
- 24 to 4GB-4 (Command Request Vectors)
- 20 to 4GB-4 (Command Response Vectors)

**Key:** The unsigned 16-bit value representing the major vector key. The major vector keys are:

- 0x4A00 (Authentication request vector)
- 0x4A01 (Authentication response vector)
- 0x4B00 (Command request vector)
- 0x4B01 (Command response vector)

**Cluster IP:** The 32 bit IP address of the cache cluster associated with the target cache partition.

**Port:** The 16 bit Port number of the cache cluster associated with the cache partition.

**Correlator:** The unsigned 32-bit value used by ECCP client to associate the command response to the command request.

**Retcode:** The unsigned 32-bit value representing the return code. This is only present in the response vectors.

Vectors contain one or more subvectors. The authentication request vector requires both the name and the password subfields. The command request vector contains one or more command subvectors. If multiple subvectors are present in the command request vector, then multiple subvectors will be present in the command response vector. If a severe error occurs, it is reflected in the Retcode field of the command response vector.

### Authentication Request Vector

The Authentication Request Vector must be the first vector on the External Cache Control Connection if the box is password protected. If the box is not password protected this vector will be ignored.

**0-3** Length

The length (in bytes) of the vector, including the length and key fields, as well as any subvectors.

**4-5** Key

0x4A00

**6-15** Reserved

Reserved for future use.

**16 to (4n-1)**

Name Subfield.

**4n to (4m-1)**

Password Subfield.

### Command Request Vector

The Command Request Vector sends commands to the External Cache Control Manager. If the box is password protected a valid Authentication Request Vector must first be received by the External Cache Control Manager before the commands are accepted.

## Using Web Server Cache

**0-3** Length

The length (in bytes) of the vector, including the length and key fields, as well as any subvectors.

**4-5** Key

0x4B00

**6-7** Port

The port number of the cache cluster (HTTP Proxy) associated with the target cache partition.

**8-11** Cluster IP Address

The IP address of a cache cluster (HTTP Proxy) associated with the target cache partition.

**12-15** Correlator

The correlator is used to associate the command responses to its matching command request.

**16 to (4n-1)**

Subvectors

One or more of the following subvectors may be appended.

- Add Object Command Subvector (0x0100)
- Add (Force) Object Command Subvector (0x0110)
- Delete Object Command Subvector (0x0400)
- Dependency Command Subvector (0x0A00)
- Disable Command Subvector (0x0300)
- Enable Command Subvector (0x0200)
- Policy Command Subvector (0x0500)
- Purge Command Subvector (0x0600)
- Query Command Subvector (0x0700)
- Statistics Command Subvector (0x0800)
- URL Mask Command Subvector (0x900)

### Authentication Response Vector

The Authentication Response Vector is returned in response to an Authentication Request Vector.

**0-3** Length

The length (in bytes) of the vector, including the length and key fields, as well as any subvectors.

**4-5** Key

0x4A01

**6-15** Reserved

Reserved for future use.

**16-19** Return Code

This is the return code for the vector. See "Return Codes" on page 194.

**20 to (4n-1)**

Subvectors



There are currently no vectors on the Authentication Response Vector.

### Command Response Vector

The Command Response Vector is returned in response to a Command Request Vector.

#### 0-3 Length

The length (in bytes) of the vector, including the length and key fields, as well as any subvectors.

#### 4-5 Key

0x4B01

#### 6-7 Port

The port number of the cache cluster (HTTP Proxy) associated with the target cache partition.

#### 8-11 Cluster IP Address

The Cluster IP Address of a cache cluster (HTTP Proxy) associated with the target cache partition.

#### 12-15 Correlator

The correlator is used to associate the command responses to its matching command request.

#### 16-19 Return Code

This is the return code for the vector. See “Return Codes” on page 194.

#### 20 to (4n-1)

Subvectors

Zero or more of the following subvectors may be appended.

- Add Object Response Subvector (0x0101)
- Add (Force) Object Response Subvector (0x0111)
- Delete Object Response Subvector (0x0401)
- Dependency Response Subvector (0x0A01)
- Disable Response Subvector (0x0301)
- Enable Response Subvector (0x0201)
- Policy Response Subvector (0x0501)
- Purge Response Subvector (0x0601)
- Query Response Subvector (0x0701)
- Statistics Response Subvector (0x0801)
- URL Mask Response Subvector (0x901)

### Subvector Formats

This section describes the subvector formats. Subvectors follow the same basic format as the major vector:

## Using Web Server Cache

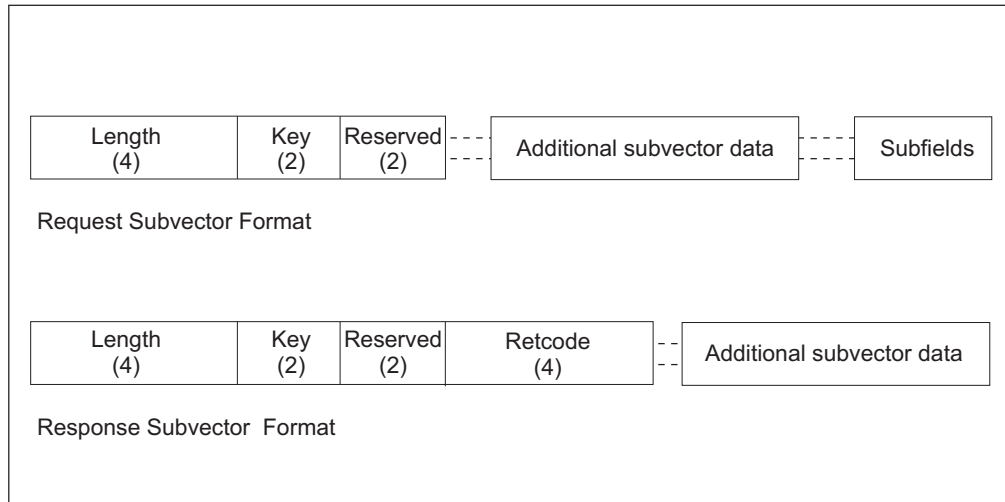

Figure 19. Subvector Format

**Length:** The unsigned 32-bit value representing the length (in bytes) of the entire subvector, including the length and key fields as well as any subfields. The acceptable range is 6-4 GB (we are not checking the upper bound)

**Key:** The unsigned 16-bit value representing the subvector key. The request subvector keys include:

- 0x0100 (Add Web object)
- 0x0110 (Add Web object, ignore cache control headers)
- 0x0200 (Enable caching on the partition)
- 0x0300 (Disable caching on the partition)
- 0x0400 (Delete a Web object)
- 0x0500 (Modify or list cache policies)
- 0x0600 (Remove all Web objects from partition)
- 0x0700 (Determine if a Web object in partition)
- 0x0800 (Reset or list cache statistics)
- 0x0900 (Add, delete, list URL masks)
- 0x0A00 (Add, delete, list, reset dependencies)

The response subvector keys returned are:

- 0x0101 (Add Web object)
- 0x0111 (Add Web object, ignore cache control headers)
- 0x0201 (Enable caching on the partition)
- 0x0301 (Disable caching on the partition)
- 0x0401 (Delete a Web object)
- 0x0501 (Modify or list cache policies)
- 0x0601 (Remove all Web objects from partition)
- 0x0701 (Determine if a Web object in partition)
- 0x0801 (Reset or list cache statistics)
- 0x0901 (Add, delete, list URL masks)
- 0x0A01 (Add, delete, list, reset dependencies)

**Reserved:** A 16 bit field not currently used.

**Retcode:** The unsigned 32-bit value representing the return code for the request subvector. This is only present in the response subvector.

**Add Object Command Subvector:** The Add Object Command Subvector is used to add a Web Object to the cache partition.

**0-3** Length

The length (in bytes) of the vector, including the length and key fields, as well as any subvectors.

**4-5** Key

0x0100

**6-7** Reserved

**8 to (4n-1)**

URL Subfield

**4n to (4m-1)**

Object Subfield

**Add (force) Object Command Subvector:** The Add (force) Object Command Subvector is used to add a Web object to the cache partition. It differs from the Add Object Command Subvector in that any Cache Control headers of the object are ignored.

**0-3** Length

The length (in bytes) of the vector, including the length and key fields, as well as any subvectors.

**4-5** Key

0x0110

**6-7** Reserved

**8 to (4n-1)**

URL Subfield

**4n to (4m-1)**

Object Subfield

**Delete Object Command Subvector:** The Delete Object Command Subvector is used to remove a Web object from the cache partition.

**0-3** Length

The length (in bytes) of the vector, including the length and key fields, as well as any subvectors.

**4-5** Key

0x0400

**6-7** Reserved

**8 to (4n-1)**

URL Subfield

## Using Web Server Cache

**Dependency Command Subvector:** The Dependency Command Subvector is used to modify/list the Dependency Table or invalidate objects using the Dependency Table.

**0-3** Length

The length (in bytes) of the vector, including the length and key fields, as well as any subvectors.

**4-5** Key

0x0A00

**6-7** Reserved

**8-9** Command

The dependency Command to be performed.

**0x0001**

Get the dependency table (see Dependency type for the dependency)

**0x0002**

Add a new dependency/dependency URL to the Dependency Table

**0x0003**

Remove a dependency/dependency URL from the Dependency Table

**0x0004**

Reset the dependency table information (see Dependency type for the dependency)

**0x0005**

Invalidate an Object based on a dependency

**0x0006**

Garbage collect the Dependency Table

**10-11** Dependency Type

The dependency type field is used to identify data to be changed. This data is then changed using the Dependency Command.

**0x0000**

No dependency type

**0x0001**

Use the command on the entire table.

- If the command above is 0x0001 (Get) - get the entire table.
- If the command above is 0x0004 (Reset) - clear the entire table.

**0x0002**

Use the Command on a dependency basis.

- If the command above is 0x0001 (Get) - get all the URLs for the given dependency.
- If the command above is 0x0004 (Reset) - clears a dependency from the table.

**0x0003**

Use the Command on a URL basis

- If the command above is 0x0001 (Get) - get all the dependency for the given dependency URL.

- If the command above is 0x0004 (Reset) - clears a dependency URL from the table.

**12 to (4n-1)**

Zero or more subfields.

**Dependency Subfield**

Note: This subfield must be first when both subfields are required.  
Required when have these Command-Dependency Type.

Command	Dependency Type
0x0001	0x0002
0x0002	0x0000
0x0003	0x0000
0x0004	0x0002
0x0005	0x0000

**URL Subfield**

Note: This subfield must be second when both subfields are required.  
Required when have these Command-Dependency Type.

Command	Dependency Type
0x0001	0x0003
0x0002	0x0000
0x0003	0x0000
0x0004	0x0003

**Disable Command Subvector:** The Disable Command Subvector is used to disable a Cache Partition.

**0-3** Length

The length (in bytes) of the vector, including the length and key fields, as well as any subvectors.

**4-5** Key

0x0300

**6-7** Reserved

**Enable Command Subvector:** The Enable Command Subvector is used to enable a Cache Partition.

**0-3** Length

The length (in bytes) of the vector, including the length and key fields, as well as any subvectors.

**4-5** Key

0x0200

**6-7** Reserved

**Policy Command Subvector:** The Policy Command Subvector allows you to modify a cache partition or list the information in a cache partition.

**0-3** Length

The length (in bytes) of the vector, including the length and key fields, as well as any subvectors.

**4-5** Key

0x0500

**6-7** Reserved

**8-9** Command

## Using Web Server Cache

The command to be performed.

**0x0001**

Get the policy

**0x0002**

Update a policy

### 10-11 Policy Type

The Policy Type is used to identify data to be changed. This data is then changed using the Policy Command.

**0x0001**

Transparent caching

**0x0002**

HTTP Cache Control Header

**0x0003**

Cache dynamic objects

**0x0004**

Cache image objects (\*.gif, \*.jpg)

**0x0005**

Cache static objects

**0x0006**

Default lifetime for dynamic objects

**0x0007**

Default lifetime for image objects

**0x0008**

Default lifetime for static objects.

**0x0009**

Time (in seconds) between garbage collection.

**0x000A**

Maximum partition size (in MB).

**0x000B**

Maximum number of objects in a cache partition.

**0x000C**

Maximum size of the object in a cache partition.

**0xFFFF**

Operate on all policies.

**Note: If the Command is a get (0x0001) this is the end of the subvector.**

### 12 to (4n-1)

One of the following depending on the Policy Type above.

If the policy Type = 0x0001, 0x0002, 0x0003, 0x0004, or 0x0005:

**12-13** Set value

- 0x0001 (Enabled)
- 0x0002 (disabled)

**14-15** Reserved

If the Policy Type = 0x0006, 0x0007, or 0x0008

**12-15** The value representing the object lifetime in minutes.  
The range is 0 to 10080, with 0 representing an object with no expiration.

If the Policy Type = 0x0009

**12-15** The value representing the cache purge interval in minutes.  
The range is 0 to 720, with 0 indicating that garbage collection should be disabled.

If the Policy Type = 0x000A

**12-13** A value representing the maximum partition size in MB. The range is 0-4095, with 0 indicating no limit.

**Note:** The value is not verified.

**14-15** Reserved

If the Policy = 0x000B

**12-15** A value representing the maximum number of objects.  
The range is 0-100000, with 0 indicating no limit.

**Note:** The value is not verified.

If the Policy = 0x000C

**12-15** A value representing the maximum size of an object in the cache partition.  
The range is 512 to 300000, entering a 0 indicates no limit.

**Note:** The value is not verified.

If the Policy = 0xFFFF

**12-13** Cache transparent (Set Value)

- 0x0001 (Enabled)
- 0x0002 (Disabled)

**14-15** HTTP Cache Control Header (Set Value)

- 0x0001 (Enabled)
- 0x0002 (Disabled)

**16-17** Cache Dynamic (Set Value)

- 0x0001 (Enabled)
- 0x0002 (Disabled)

**18-19** Cache Image (Set Value)

- 0x0001 (Enabled)
- 0x0002 (Disabled)

**20-21** Cache Static (Set Value)

- 0x0001 (Enabled)
- 0x0002 (Disabled)

**22-23** A value representing the maximum partition size in MB.

## Using Web Server Cache

The range is 0 to 4095, with 0 indicating no limit.

**Note:** The value is not verified.

**24-27** A value representing the maximum number of objects.

The range is 0 to 1000000, with 0 indicating no limit.

**Note:** The value is not verified.

**28-31** A value representing the maximum size of an object in a cache partition.

The range is 512-3000000, specifying 0 indicates no limit.

**Note:** The value is not verified.

**32-35** A value representing the dynamic object lifetime in minutes.

The range is 0 to 10080, with 0 representing an object with no expiration.

**Note:** The value is not verified.

**36-39** A value representing the image object lifetime in minutes.

The range is 0 to 10080, specifying 0 indicates no limit.

**Note:** The value is not verified.

**40-43** A value representing the static object lifetime in minutes.

The range is 0 to 10080, with 0 representing no limit.

**Note:** The value is not verified.

**44-47** A value representing the cache purge interval in minutes.

The range is 0 to 720, with 0 indicating that garbage collection must be enabled.

**Purge Command Subvector:** The Purge Command Subvector is used to clear all the objects from a cache partition.

**0-3** Length

The length (in bytes) of the vector, including the length and key fields, as well as any subvectors.

**4-5** Key

0x0600

**6-7** Reserved

**Query Command Subvector:** The Query Command Subvector is used to check if a given URL is in the cache partition.

**0-3** Length

The length (in bytes) of the vector, including the length and key fields, as well as any subvectors.

**4-5** Key

0x0700



6-7 Reserved

**8 to (4n-1)**

The URL Subfield

**Statistics Command Subvector:** The Statics Command Subvector is used to get/reset the statistics for a cache partition.

**0-3** Length

The length (in bytes) of the vector, including the length and key fields, as well as any subvectors.

**4-5** Key

0x0800

6-7 Reserved

**8-9** Command

- 0x0001 - Get the statistics for the cache partition.
- 0x0004 - Reset the statistics for the cache partition.

**10-11** Reserved

**URL Mask Command Subvector:** The URL Mask Command Subvector is used to list/modify the URL masks associated with a cache partition.

**0-3** Length

The length (in bytes) of the vector, including the length and key fields, as well as any subvectors.

**4-5** Key

0x0900

6-7 Reserved

**8-9** Command

- 0x0001 - Get the URL masks currently defined (see URL Type below for type of masks to return).
- 0x0002 - Add the given URL mask (see URL Type below for the type of mask being added).
- 0x0003 - Delete the given URL mask (see URL Type below for the type of mask being deleted).

**Note:** Deleting the dynamic URL mask or the Host-On-Demand Client Cache applet mask is an invalid function.

- 0x0004 - Reset all the URL mask of the URL Type given below.

**10-11** The URL Type

- 0x0001 - Include
- 0x0002 - Exclude
- 0x0003 - Dynamic
- 0x0004 - Host On-Demand Client Cache applet

**12-15** Lifetime

The range is 0-10080, with 0 representing an object with no expiration. Used only for Add (0x0002) command when URL type is Include (0x0001), Dynamic (0x0003), or Host On-Demand Client Cache applet (0x0004).

## Using Web Server Cache

**Note:** If the Command is GET (0x0001) or Clear (0x0004) this is the end of the subvector.

### 16 to (4n-1)

One URL Command subvector.

**Add Object Response Subvector:** The Add Object Response Subvector is used to respond to an Add (force) Object Command Subvector.

#### 0-3 Length

The length (in bytes) of the vector, including the length and key fields, as well as any subvectors.

#### 4-5 Key

0x0101

#### 6-7 Reserved

#### 8-11 Return Code

See "Return Codes" on page 194.

**Add (force) Response Subvector:** The Add (force) Response Subvector is used to respond to an Add (force) Object Command Subvector.

#### 0-3 Length

The length (in bytes) of the vector, including the length and key fields, as well as any subvectors.

#### 4-5 Key

0x0111

#### 6-7 Reserved

#### 8-11 Return Code

See "Return Codes" on page 194.

**Delete Object Response Subvector:** The Delete Object Response Subvector is used to respond to an Add (force) Object Command Subvector.

#### 0-3 Length

The length (in bytes) of the vector, including the length and key fields, as well as any subvectors.

#### 4-5 Key

0x0401

#### 6-7 Reserved

#### 8-11 Return Code

See "Return Codes" on page 194.

**Dependency Response Subvector:** The Dependency Response Subvector is used to respond to a Dependency Command Subvector.

#### 0-3 Length

The length (in bytes) of the vector, including the length and key fields, as well as any subvectors.

#### 4-5 Key

0x0A01

|

**6-7** Reserved

|

**8-11** Return Code

|

See “Return Codes” on page 194.

## Using Web Server Cache

### 12 to (4n-1)

Zero or more subfields.

#### Dependency Subfield

Note: This subfield must be before the URL Command Subfields that are for the dependency. Required when have these Command-Dependency Type. For more information see "Dependency Command Subvector" on page 178.

Command	Dependency Type
0x0001	0x0001

Note: Any URL Subfields following the Dependency Subfield are dependency URLs on that dependency.

0x0001	0x0003
--------	--------

#### URL Subfield

Note: This subfield must be second when both subfields are required. Required when have these Command-Dependency Type.

Command	Dependency Type
0x0001	0x0001

Note: The Dependency Subfield prior to the URL Subfield indicates the URL for the dependency.

0x0001	0x0002
--------	--------

**Disable Response Subvector:** The Disable Response Subvector is used to respond to the Disable Command Subvector.

#### 0-3 Length

The length (in bytes) of the vector, including the length and key fields, as well as any subvectors.

#### 4-5 Key

0x0301

#### 6-7 Reserved

#### 8-11 Return Code

See "Return Codes" on page 194.

**Enable Response Subvector:** The Enable Response Subvector is used to respond to the enable Command Subvector.

#### 0-3 Length

The length (in bytes) of the vector, including the length and key fields, as well as any subvectors.

#### 4-5 Key

0x0201

#### 6-7 Reserved

#### 8-11 Return Code

See "Return Codes" on page 194.

**Policy Response Subvector:** The Policy Response Subvector is used to respond to the Policy Command Subvector.

#### 0-3 Length

The length (in bytes) of the vector, including the length and key fields, as well as any subvectors.

#### 4-5 Key

0x0501

6-7 Reserved

8-11 Return Code

See "Return Codes" on page 194.

**If the Policy Command Subvector was PUT (0x0002) this is the end of the subvector.**

**12 to (4n-1)**

One of the following depending on the Policy Type from the Policy Command Subvector.

If the policy Type = 0x0001, 0x0002, 0x0003, 0x0004, or 0x0005:

**12-13** Set value

- 0x0001 (Enabled)
- 0x0002 (disabled)

**14-15** Reserved

If the Policy Type = 0x0006, 0x0007, or 0x0008

**12-15** The value representing the object lifetime in minutes.

The range is 0 to 10080, with 0 representing an object with no expiration.

If the Policy Type = 0x0009

**12-15** The value representing the cache purge interval in minutes.

The range is 0 to 720, with 0 indicating that garbage collection should be disabled.

If the Policy Type = 0x000A

**12-13** A value representing the maximum partition size in MB. The range is 0-4095, with 0 indicating no limit.

**Note:** The value is not verified.

**14-15** Reserved

If the Policy = 0x000B

**12-15** A value representing the maximum number of objects.

The range is 0-100000, with 0 indicating no limit.

**Note:** The value is not verified.

If the Policy = 0x000C

**12-15** A value representing the maximum size of an object in the cache partition.

The range is 512 to 300000, entering a 0 indicates no limit.

**Note:** The value is not verified.

If the Policy = 0xFFFF

**12-13** Cache transparent (Set Value)

## Using Web Server Cache

- 0x0001 (Enabled)
- 0x0002 (Disabled)

### 14-15 HTTP Cache Control Header (Set Value)

- 0x0001 (Enabled)
- 0x0002 (Disabled)

### 16-17 Cache Dynamic (Set Value)

- 0x0001 (Enabled)
- 0x0002 (Disabled)

### 18-19 Cache Image (Set Value)

- 0x0001 (Enabled)
- 0x0002 (Disabled)

### 20-21 Cache Static (Set Value)

- 0x0001 (Enabled)
- 0x0002 (Disabled)

### 22-23 A value representing the maximum partition size in MB.

The range is 0 to 4095, with 0 indicating no limit.

**Note:** The value is not verified.

### 24-27 A value representing the maximum number of objects.

The range is 0 to 1000000, with 0 indicating no limit.

**Note:** The value is not verified.

### 28-31 A value representing the maximum size of an object in a cache partition.

The range is 512-3000000, specifying 0 indicates no limit.

**Note:** The value is not verified.

### 32-35 A value representing the dynamic object lifetime in minutes.

The range is 0 to 10080, with 0 representing an object with no expiration.

**Note:** The value is not verified.

### 36-39 A value representing the image object lifetime in minutes.

The range is 0 to 10080, specifying 0 indicates no limit.

**Note:** The value is not verified.

### 40-43 A value representing the static object lifetime in minutes.

The range is 0 to 10080, with 0 representing no limit.

**Note:** The value is not verified.

### 44-47 A value representing the cache purge interval in minutes.

The range is 0 to 720, with 0 indicating that garbage collection must be disabled.

**Purge Response Subvector:** The Purge Response Subvector is used to respond to a Purge Command Subvector.

**0-3** Length

The length (in bytes) of the vector, including the length and key fields, as well as any subvectors.

**4-5** Key

0x0601

**6-7** Reserved

**8-11** See “Return Codes” on page 194.

**Query Response Subvector:** The Query Response Subvector is used to check if a given URL is in the cache partition.

**0-3** Length

The length (in bytes) of the vector, including the length and key fields, as well as any subvectors.

**4-5** Key

0x0701

**6-7** Reserved

**8-11** Return Code

See “Return Codes” on page 194.

**Note: If the return code is bad (not 0x00000000), this is the end of the response.**

**12-39** The time the object was last modified in the GMT.

**Note:** This field will not exist if the return code was not 0x00000000 or if it is not known by the Cache Partition.

**12-15** Seconds

**16-19** Minutes

**20-23** Hours

**24-27** Months since Jan. (0-11)

**28-31** Years from 1900

**32-35** Days since Sunday (0-6)

**36-39** Day of the month

**Statistics Response Subvector:** The Statistics Response Subvector responds to the Statistics Command Subvector.

**0-3** Length

The entire length (in bytes) of the vector, including the length and key fields, as well as any subvectors.

**4-5** Key

0x0801

**6-7** Reserved

## Using Web Server Cache

### 8-11 Return Code

This is the return code for the subvector.

### 12-

- 12-15** The current number of bytes in the Cache Partition. The number only reflects the entity bytes, and does not include the bytes used to store the headers or control block usage.
- 16-19** The high water mark for the number of bytes in the Cache Partition.
- 20-23** The current number of objects in the Cache Partition.
- 24-27** The high water mark for the number of objects in the Cache Partition.
- 28-31** The total of times that objects were found in the Cache Partition.
- 32-35** The total of times that objects were not found in the Cache Partition.
- 36-39** The number of objects added to the Cache Partition explicitly by Include URL mask.
- 40-43** The number of objects not added to the Cache Partition because caching was turned off.
- 44-47** The number of objects not added to the cache partition because the object is too big.
- 48-51** The number of objects not added to the Cache Partition because DONT CACHE is specified in the HTTP control header.
- 52-55** The number of object not added to the Cache Partition because explicitly excluded by the URL mask.
- 56-59** The number of objects not added to the Cache Partition because the object was stale.
- 60-63** The number of objects not added to the Cache Partition because the image object explicitly not cached.
- 64-67** The number of objects not added to the Cache Partition because the static object explicitly not cached.
- 68-71** The number of objects not added to the Cache Partition because the dynamic object was not explicitly cached.
- 72-75** The number of objects purged due to a full cache or all the cache partitions exceed the total amount allowed by the Web Server Cache.
- 76-79** The number of objects purged due to the expiration of the objects lifetime.
- 80-83** The number of objects explicitly purged, either by giving the URL or purging the entire partition.
- 84-87** The number of objects purged due to the invalidation of the dependency.
- 88-91** The number of items deleted from the partition due to the External Cache Control Interface (delete).
- 92-95** The number of items added to the partition via the External Cache Control Interface.



- 96-99** The number of items not added to the partition via External Cache Control Interface but had tried to be added via that interface.
- 100-103** The number of items replaced in the partition via the External Cache Control Interface.
- 104-107** The number of 200 (OK) sent back when there was a cache hit.
- 108-111** The number of 203 (Non\_Authoritative) responses sent back when there was a cache hit.
- 112-115** The number of 206 (Partial Content) responses sent back when there was a cache hit.
- 116-119** The number of 300 (Multiple Choices) responses sent back when there was a cache hit.
- 120-123** The number of 301 (Moved Permanently) responses sent back when there was a cache hit.
- 124- 127** The number of 304 (Not Modified) responses sent back when there was a cache hit.
- 128-131** The number of 410 (Gone) responses sent back when there was a cache hit.
- 132-135** The number of 100 range (Informational) responses sent back when there was no cache hit.
- 136-139** The number of 200 (OK) responses sent back when there was no cache hit.
- 140-143** The number of 200 range (Successful) responses sent back when there was no cache hit (not including 200 response).
- 144-147** The number of 304 (Not Modified) responses sent back when there was no cache hit.
- 148-151** The number of 300 range (Redirection) responses sent back when there was no cache hit (not including 304 messages).
- 152-155** The number of 400 range (Client error) responses sent back when there was no cache hit.
- 156-159** The number of 500 range (Server error) responses sent back when there was no cache hit.

## Using Web Server Cache

### 160-163

The number of other (does not fit into any of the above) responses sent back when there was no cache hit.

### 164-167

The number of bytes served due to a cache hit (note: does not include the HTTP headers).

### 168-171

The number of bytes served due to no cache hit (note: does not include the HTTP headers).

**URL Mask Response Subvector:** The URL Mask Response Subvector is used to respond to a URL Mask Command Subvector.

#### 0-3 Length

The length (in bytes) of the vector, including the length and key fields, as well as any subvectors.

#### 4-5 Key

0x0901

#### 6-7 Reserved

#### 8-11 Return Code

This is the return code for the subvector. See “Return Codes” on page 194.

#### 12 to (4n-1)

Zero or more URL Subvectors if the URL Mask Command Subvector was GET (0x0001).

## Subfield Formats

This section describes the field descriptions for the subfields.

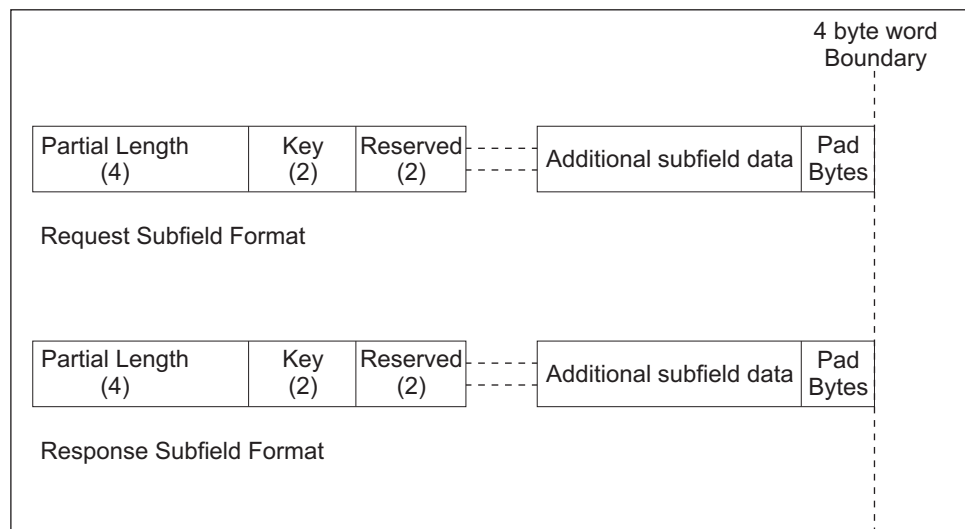

Figure 20. Subfield Format

**Partial Length:** The unsigned 32-bit value representing the length (in bytes) of the entire subfield, including the length and key fields, but excluding the padding bytes. The subfields are padded so that they will be aligned with the 4-byte (word) boundaries. The acceptable range is 6 to 4GB.

**Key:** The unsigned 16-bit value representing the subfield key. The command subfield keys include:

- 0x0010 (Uniform Resource Locator, stripped of the protocol "http:" and Internet resource address. For example, the URL "http://192.9.200.50/file1.html" would be sent as "/file1.html").
- 0x0020 (Web object in an HTTP response message format)
- 0x0030 (Name of ECCP user. This subfield is required for the authentication vector).
- 0x0040 (Password of ECCP user. This subfield is required for the authentication vector).
- 0x0050 (Dependency Subfield)

The response subfield keys are:

- 0x0011 (Uniform Resource Locator stripped of the protocol "http:" and Internet resource address).
- 0x0051 (Dependency Subfield)

**Reserved:** A 16 bit field currently not used.

**Dependency Subfield:** The Dependency Subfield for the URL Mask Response Subvector.

**0-3** Partial Length

The length (in bytes) of the subfield as in Figure 20 on page 192.

**4-5** Key

0x0050 - request

0x0051 - response

**6-7** Reserved

**8 to (4n-1)**

Dependency and Pad Bytes

The dependency must be 1 to 50 in length.

**Name Subfield:** The Name Subfield for the URL Mask Response Subvector.

**0-3** Length

The length (in bytes) of the subfield as in Figure 20 on page 192.

**4-5** Key

0x0030 - request

**6-7** Reserved

**8 to (4n-1)**

Name and Pad Bytes

The name Must be 1 to 8 in length.

**Object Subfield:** The Object Subfield for the URL Mask Response Subvector.

**0-3** Length

The length (in bytes) of the subfield as in Figure 20 on page 192.

**4-5** Key

## Using Web Server Cache

0x0020 - request

**6-7** Reserved

**8 to (4n-1)**

Object and Pad Bytes

The object must be formatted like a HTTP Response. It is an array of characters.

**Password Request Subfield:** The Password Request Subfield for the URL Mask Response Subvector.

**0-3** Length

The length (in bytes) of the subfield as in Figure 20 on page 192.

**4-5** Key

0x0040

**6-7** Reserved

**8-15** The seed used in encryption (must be 8 bytes).

**16 to (4n-1)**

Password and Pad Bytes

The password must be 1 to 8 bytes in length and be encrypted.

**URL Request Subfield:** The URL Request Subfield for the URL Mask Response.

**0-3** Length

The length (in bytes) of the subfield as in Figure 20 on page 192.

**4-5** Key

0x0010 - request

0x0011 - response

**6-7** Reserved

**8 to (4n-1)**

URL or URL Mask and Pad Bytes

This URL or URL Mask is an array of characters, the array must be 1 to 255 in length.

### Return Codes

It is important to check the return codes for each response subvector in addition to the return code in the response vector. The return code for the response vector will be set to a non-zero value if a severe error was detected, in which case all the command subvectors from the command vector might or might not have a corresponding response subvector.

#### **Return Codes and Descriptions:**

0000 0000: Operation was successful  
0001 0000: Object not found  
0002 0000: Cache partition is already enabled  
0003 0000: Cache partition is already disabled.  
0004 0000: Cache partition is not enabled  
0005 0000: Cache partition is not defined  
0006 0000: Cache partition is terminating

0007 0000: URL subfield is required but not present  
0008 0000: Purge interval provided is not valid  
0009 0000: Unsupported Set value  
000A 0000: Unsupported Command value  
000B 0000: Unsupported Policy type value  
000C 0000: Unsupported URL type value  
000D 0000: Unsupported vector key  
000E 0000: Unsupported subvector key  
000F 0000: Unable to parse object's headers  
0010 0000: Unable to obtain storage  
0011 0000: Object too large to add to partition  
0012 0000: Vector format is not valid  
0013 0000: Object is not cachable  
0014 0000: HTTP parse error detected  
0015 0000: Object subfield is required but not present  
0016 0000: Dependency subfield is not provided or invalid  
0017 0000: Authentication Vector required  
0018 0000: Authentication Vector not required - therefore ignored  
0019 0000: Dependency was not in Dependency table  
001A 0000: Dependency URL was not in Dependency table  
001B 0000: Unsupported Depend type  
001C 0000: Bad userid/password/permission for ECC  
001D 0000: Bad URL mask type for the image load on the box  
FF01 yyyy: Command failed. Last 2 bytes contain additional information.  
    0101: Object was not found.  
    0102: Object cannot be cached.  
    0103: Object already exists in partition.  
    0104: Partition initialization failed, maximum number of partitions  
          already active.  
    0105: Partition is active.  
    0106: Partition is not active.  
    0107: The partition is in a pending state and cannot execute the command.  
          Wait a few seconds and try the command again.  
    0108: Partition is not defined.  
    0109: URL type is not supported.  
    010A: URL pointer is not valid.  
    010B: Partition number is not valid.  
    010C: Partition command is not supported.  
    010D: Partition pointer is not valid.  
    010E: Partition handle does not reference an active partition.  
    010F: Partition handle does not reference a valid partition.  
    0110: Policy pointer is required but not present.  
    0111: Statistics pointer is required but not present.  
    0112: Purge interval is too large.  
    0113: Dependency already has URL on it.  
0FFF: External cache control is not available.  
FFF9: Unable to acquire storage.  
FFFA: Unable to acquire a partition handle.  
FFFB: Policy SRAM pointer is required but not present.  
FFFC: Partition SRAM pointer is required but not present.  
FFFD: Unable to allocate/initialize cache expiration interval.  
FFFE: Unable to allocate/initialize cache partition.  
FFFF: Unable to allocate/initialize cache core.

## Using Web Server Cache

---

## Chapter 12. Configuring and Monitoring Web Server Cache

This chapter describes how to configure Web Server Cache feature and use the Web Server Cache monitoring commands. It contains:

- “Configuring the Web Server Cache”
- “Accessing the Web Server Cache Environment” on page 203
- “Web Server Cache Commands” on page 203
- “Accessing the Web Server Cache Monitoring Environment” on page 209
- “Web Server Cache Monitoring Commands” on page 210
- “Web Server Cache Dynamic Reconfiguration Support” on page 215

---

### Configuring the Web Server Cache

Web Server Caching must be used with Network Dispatcher. Before you use Web Server Cache the first time you must:

1. Access Network Dispatcher in talk 6 from the Config> prompt using the **feature ndr** command.
2. Enable executor
3. Add a cluster
4. Add a port
5. Add one or more servers.

Then you can use the configuration and monitoring commands to alter the Web Server Cache environment.

**Note:** While the Network Dispatcher changes done via Talk 6 change the current running configuration, the changes for the Web Server Cache do not change the current running configuration unless explicitly activated via the **activate** command in Talk 6 or in Talk 5 feature Webc. The exception to this is if the cluster/port for an HTTP Proxy is removed via Talk 6 feature NDR it will cause the HTTP proxy for the Web Server Cache to also be removed from the current running configuration.

#### Example:

```
Config>f ndr
NDR Config>enable executor
NDR Config>add cluster
Cluster Address [0.0.0.0]? 113.3.1.10
FIN count [4000]?
FIN time out [30]?
FIN stale timer [1500]?
Cluster 113.3.1.12 has been added.
Fincount has been set to 4000 for cluster 113.3.1.10
Fintimeout has been set to 30 for cluster 113.3.1.10
Staletimer has been set to 1500 for cluster 113.3.1.10
NDR Config>add port
Cluster Address [0.0.0.0]? 113.3.1.10
Port number [80]?
Port type (tcp=1, upd=2, both=3) [3]?
Max. weight (0-100) [20]?
Only one pftp port per cluster allowed
Port mode (none=0, sticky=1 pftp=2 cache=3 extcache=4) [0]? 3
Do you want a new cache partition? [Yes]:
Enter cache partition [0]?
Default server TCP connection timeout (Range 5-240 seconds) [120]?
Default client TCP connection timeout (Range 5-240 seconds) [120]?
Maximum partition size (1-4095 megabytes or 0 for no limit) [0]?
Maximum number of objects (1-100000 or 0 for no limit) [0]?
Maximum object size (512-300000 bytes or 0 for no limit) [0]?
Do you want the cache enabled upon reboot? [Yes]:

Default cache purge interval (1-720 minutes or 0 to disable) [10]
```

## Configuring and Monitoring Web Server Cache

```
Enable transparent caching? [Yes]:
Check cache control headers? [Yes]:
Cache images? [Yes]:
    Default expiration time for images
    (1-10080 minutes or 0 for no expiration) [60]?
Cache non-image static objects? [Yes]:
    Default expiration time for non-image static objects
    (1-10080 minutes or 0 for no expiration) [60]?
URL mask to identify dynamic objects [*/cgi*]?
Cache dynamic objects? [No]:
Do you want to add a URL mask? [No]:

Cache partition number 1 has been successfully created.
Requested port has been added to cluster 113.3.1.10
Maxweight has been set to 20 for port 80 in cluster 113.3.1.10
NDR Config>add server
Cluster Address [0.0.0.0] ? 113.3.1.10
Port number [80] ? 80
Server Address [0.0.0.0] ? 113.1.2.0
Server weight [20] ?
Server state (down=0, up=1) [1] ?
Server 113.1.2.0 has been added to the requested port(s) of cluster 113.3.1.10
Weight of server 113.1.2.0 has been set to 20 in port 80 of cluster 113.3.1.10
Server 113.1.2.0 has been set up.
NDR Config> exit
```

The following lists the example parameters specific to the Web Server Cache and their descriptions.

### **cluster-address**

Specifies the IP address for the cluster.

**Note:** Cluster IP Addresses are assumed to be on the same logical subnet as the previous hop router (IP router), unless Cluster Address Advertising is used for the cluster.

**Valid Values:** Any valid IP address

**Default Value:** 0.0.0.0

### **FIN-count**

Specifies the number of connections that must be in FIN state before the executor tries to remove the unused connection information from the Network Dispatcher database after *FIN-timeout* or *Stale-timer* has elapsed.

**Valid Values:** 0 to 65535

**Default value:** 4000

### **FIN-timeout**

Specifies the number of seconds, that a connection has been in the FIN state, after which the executor tries to remove the unused connection information from the Network Dispatcher database.

**Valid Values:** 0 to 65535

**Default Value:** 30

### **Stale-timer**

Specifies the number of seconds, that a connection has been inactive, after which the executor tries to remove a connection's information from the Network Dispatcher database.

**Valid Values:** 0 to 65535

**Default Value:** 1500

### **port#**

Specifies the port number of the protocol for this cluster.

**Valid Values:** 1 to 65535



## Configuring and Monitoring Web Server Cache

**Default Value:** 80

**port-type**

Specifies the types of IP traffic that can be load balanced on this port. Supported types are:

- 1 = TCP
- 2 = UDP
- 3 = both

**Valid Values:** 1, 2, 3

**Default Value:** 3

**max-weight**

Specifies the maximum weight for servers on this port. This affects how much difference there can be between the number of requests the executor will give each server.

**Valid Values:** 0 to 100

**Default Value:** 20

**port-mode**

Specifies whether the port will feed all requests from a single client to a single server (known as sticky), use passive ftp (pftp), use Web Server Cache (cache), feed an external scalable cache array (extcache), or use no particular protocols on this cluster (none).

**Valid Values:** 0 - 4, where:

- 0 = none
- 1 = sticky
- 2 = pftp
- 3 = cache
- 4 = extcache

**Default value:** 0

**Do you want a new cache partition?**

Specifies whether you want to use an existing cache partition or a new partition.

**Valid Values:** Yes or No

**Default Value:** Yes

**Enter cache partition**

Specifies the number of the existing cache partition to be used.

**Valid Values:** Any existing cache partition number

**Default Value:** 0

**Default server TCP connection timeout**

Specifies the time before a server connection expires.

**Valid Values:** 5 to 240 seconds

**Default Value:** 120 seconds

**Do you want to modify cache partition?**

Allows you to modify the configuration of an existing cache partition.

**Valid Values:** Yes or No

**Default Value:** No

## Configuring and Monitoring Web Server Cache

### Default client TCP connection timeout

Specifies the time before a client connection expires.

**Valid Values:** 5 to 240 seconds

**Default Value:** 120 seconds

### Maximum partition size

Specifies the maximum amount of memory to be allocated to this cache partition. If this value exceeds the amount of memory currently available, it will be ignored and no maximum partition size will be imposed.

**Valid Values:** 1 to 4095 Megabytes or 0 (no maximum)

**Default Value:** 0 (no maximum)

### Maximum number of objects

Specifies the maximum number of objects that can be stored in a cache partition. If the user enters a 0, the cache partition will be limited only by the amount of memory available to the partition.

**Valid Values:** 1 to 100000 or (no limit)

**Default Value:** 0 (no limit)

### Maximum object size

Specifies the maximum size for objects to be included in the cache. Objects exceeding this maximum size will never be included in the cache. If the maximum object size is changed after the cache has been populated, it is possible that objects already in the cache may temporarily exceed the defined maximum.

**Valid Values:** 512 to 300000 bytes or 0 (no maximum size)

**Default Value:** 0 (no maximum size)

### Do you want the cache enabled upon reboot?

Specifies whether a cache partition should be enabled automatically or upon explicit user request. Cache partitions that are set for immediate enabling are automatically enabled when the 2212 is rebooted. Cache partitions that are not set for immediate enabling will remain available, but in the disabled state until the user enables the partition from the Web Server Cache console in talk 5.

**Valid Values:** Yes or No

**Default Value:** Yes

### Default cache purge interval?

Specifies the default cache purge interval.

**Valid Values:** 1 to 720 minutes or 0 (disable)

**Default Value:** 10 minutes

### Enable transparent caching?

Specifies whether server responses for objects not found in the cache (cache misses) will automatically be cached. The alternative is to use the ECCP to manipulate the cache.

**Valid Values:** Yes or No

**Default Value:** Yes

## Configuring and Monitoring Web Server Cache

### Check cache control headers?

Allows a server to specify to the Web Server Cache whether or not the response is eligible to be cached.

**Valid Values:** Enabled or Disabled

**Default Value:** Disabled

### Cache images?

Specifies whether image files (\*.gif or \*.jpg) are to be cached.

**Valid Values:** Yes or No

**Default Value:** Yes

### Default expiration time for images

**Valid Values:** 1 to 10080 minutes, or 0 (none)

**Default Values:** 60 minutes

### Cache non-image static objects?

Specifies whether non-image static data (files that do not contain \*/cgi\* and files that do not end in .jpg or .gif) are to be cached.

**Valid Values:** Yes or No

**Default Value:** Yes

### Default expiration time for non-image static objects

**Valid Values:** 1 to 10080 minutes, or 0 (none)

**Default Values:** 60 minutes

### URL mask to identify dynamic objects

Specifies the URL mask used to identify dynamic objects.

**Valid Values:** any URL mask

**Default Value:** \*/cgi\*

### Cache dynamic objects?

Specifies whether to cache dynamic objects. Dynamic objects are objects that have been constructed by the server when the object is requested and are reconstructed for each new request whether the data has changed or not.

**Valid Values:** Yes or No

**Default Value:** No

### Do you want to add a URL mask?

Specifies a new URL mask to be added to the cache. URL masks allow the user to include or exclude individual objects or groups of objects by their Universal Resource Locator (URL).

**Valid Values:** i or e

**Default Value:** i

Wildcard characters can be used when specifying a URL mask. Wildcards can be used when configuring Network Dispatcher for the Web Server Cache or when using the **add** or **modify url** command from the `f webc` prompt. The characters used as wildcards are an \* (asterisk) or a # (number sign). Wildcards can be used in any position as a part of the URL.

## Configuring and Monitoring Web Server Cache

The \* represents any number of characters, including zero characters, as a part of that URL:

**Example:** \*abc.html would filter the following URL masks.

```
abc.html
finabc.html
defchtjqsprabc.html
```

The # represents any single character.

**Example:** ab#.html would filter the follow URL masks.

```
abc.html
abf.html
abo.html
```

The following example applies when port mode 3 (cache=3) is selected and a new cache partition is not being added.

```
NDR Config>add port
Cluster Address [0.0.0.0] ? 113.3.1.11
Port number [80] ?
Max. weight (0-100) [20] ?
Only one pftp port per cluster allowed
Port mode (none=0, sticky=1 pftp=2 cache=3 extcache=4) [0] ? 3
Do you want a new cache partition? [Yes] : n
Enter cache partition [0] ? 0
Maximum TCP segment size (Range 512-32768 bytes) [4096] ?
Default server TCP connection timeout (Range 5-240 seconds) [120] ?
Default client TCP connection timeout (Range 5-240 seconds) [120] ?
Do you want to modify cache partition [0]? No :
Requested port has been added to cluster 113.3.1.11
Maxweight has been set to 20 for port 80 in cluster 113.3.1.11
```

**Note:** The following example applies when port mode 3 (cache=3) is selected and a new cache partition is being added.

```
NDR Config>add port
Cluster Address [0.0.0.0]? 113.3.1.10
Port number [80]?
Port type(tcp=1, udp=2, both=3) [3]?
Max. weight (0-100) [20]?
Only one pftp port per cluster allowed
Port mode (none=0, sticky=1 pftp=2 cache=3 extcache=4) [0]? 3
Do you want a new cache partition? [Yes]: y
Default server TCP connection timeout (Range 5-240 seconds) [120]?
Default client TCP connection timeout (Range 5-240 seconds) [120]?
Maximum partition size (1-4095 megabytes or 0 for no limit) [0]?
Maximum number of objects (1-100000 or 0 for no limit) [0]?
Maximum object size (512-300000 bytes or 0 for no limit) [0]?
Do you want the cache enabled upon reboot? [Yes]:

Default cache purge interval (1-720 minutes or 0 to disable) [10]?
Enable transparent caching? [Yes]:
Check cache control headers? [Yes]:
Cache images? [Yes]:
    Default expiration time for images
    (1-10080 minutes or 0 for no expiration) [60]?
Cache non-image static objects? [Yes]:
    Default expiration time for non-image static objects
    (1-10080 minutes or 0 for no expiration) [60]?
URL mask to identify dynamic objects [*/cgi*]?
Cache dynamic objects? [No]:
Do you want to add a URL mask? [No]:

Cache partition number 0 has been successfully created.
Requested port has been added to cluster 113.3.1.10
Maxweight has been set to 20 for port 80 in cluster 113.3.1.10
Port Type has been set to Both for port 85 in cluster 113.3.1.10
NDR Config>
```

## Configuring and Monitoring Web Server Cache

You must use Network Dispatcher to configure the initial cluster and port for the Web Server Caching feature. Once you have added the cluster and port, configuring the *port mode* as a cache port, you can then modify and display Web Server Caching configuration parameters at the WEBC Config> prompt.

See on page 118 for information about Network Dispatcher.

---

## Accessing the Web Server Cache Environment

To access the Web Server Cache configuration environment, enter the following command at the Config> prompt.

```
Config> feature webc
WEBC Config>
```

---

## Web Server Cache Commands

This section describes the Web Server Cache Configuration commands. Table 18 lists the Web Server Cache configuration commands. These commands specify the Web Server Cache feature parameters. To activate these changes restart the router.

Table 18. Web Server Cache Configuration Commands Summary

Command	Function
? (Help)	Displays all the commands available for this command level or lists the options for specific commands (if available). See “Getting Help” on page xxxii.
Activate	Activates or reactivates cache partitions, using the latest configuration.
Add	Adds a URL mask.
Delete	Deletes a URL mask or a partition.
List	Lists the caching information.
Modify	Modifies the caching information.
Exit	Returns you to the previous command level. See “Exiting a Lower Level Environment” on page xxxii.

### Activate

Use the **activate** command to initialize all cache partitions, using the latest configuration.

**Syntax:**  
**activate**

**Example:**

```
WEBC Config>act ?
ACTIVATE all initializes cache partitions, using
the latest configuration.
```

### Add

Use the **add** command to add a URL mask.

**Syntax:**  
**add** urlmask

**Example:**

```
WEBC Config>add ur1
Partition number [0]?
New URL mask []? *newmask*
Include or Exclude from cache (i or e) [i]? i
Set default expiration time? [No]:y
```

## Configuring and Monitoring Web Server Cache

Default expiration time  
(1-10080 minutes or 0 for no expiration) [0]? 20  
The URL mask has been added to cache partition number 0.

**Note:** To add proxies and partitions, you must use Network Dispatcher and go through the **add port** or **set port** commands.

### partition number

The partition number for the partition to be added.

**Valid Values:** any valid partition number

**Default Value:** 0

### new URL mask

The name for the URL mask to be added.

**Valid Values:** Any valid URL mask

**Default Value:** none

### include or exclude from cache

Specifies whether to include in or exclude the URL from the cache.

**Valid Values:** i or e

**Default Value:** i

### default expiration time

Specifies the default expiration time in minutes. Zero specifies no expiration time.

**Valid Values:** 0 to 10080 minutes

**Default Value:** 0 (no expiration time)

## Delete

Use the **delete** command to delete a URL mask or a partition from the configuration database.

### Syntax:

```
delete           partition  
                  urlmask
```

**partition** The number of the partition to be deleted from a cache.

**urlmask** The name of the URL mask to be deleted from a cache.

### Example:

```
WEBC Config>delete url  
Partition number [0]? 0  
URL masks defined : 5  
  1: EXCLUDE '*index*'      Default expiration time: 1 minutes  
  2: EXCLUDE '*comp*'      Default expiration time: 5 minutes  
  3: INCLUDE '*tmp*'       Default expiration time: 1000 minutes (16 hrs 40 mins)  
  4: INCLUDE '*stat*'      Default expiration time: 1000 minutes (16 hrs 40 mins)  
  5: INCLUDE '*html*'      Default expiration time: 1000 minutes (16 hrs 40 mins)  
URL mask number [1]? 5  
The URL mask for cache partition number 0 has been deleted.
```

**Note:** You must delete all proxies using a partition prior to deleting the partition. To delete a proxy you must use the Network Dispatcher feature and remove the associated port and/or cluster, or change the port mode of the port to something other than cache.

## Configuring and Monitoring Web Server Cache

### partition number

The partition number of the partition to be deleted.

**Valid Values:** any valid partition

**Default Value:** 0

### URL mask number

The number of the URL mask to be deleted.

**Valid Values:** any valid URL mask number.

**Default Value:** 1

## List

Use the **list** command to list the Web Server Cache information.

### Syntax:

```
list all
      external
      partition
      proxy
      urlmask
```

**all** Lists all the ports, partitions, proxies and masks defined in a cache.

**external** Lists the information for the External Cache Control Manager.

**partition** Lists the partition numbers in a cache.

**proxy** Lists the proxies defined in a cache.

**urlmask** List the URL masks defined in a cache.

### Example: list all

```
WEBC Config>list all
Cache Partition 0
  Cluster address 113.3.1.10, Port 80
```

1 cache partition(s) defined.

### Example: list external

```
WEBC Config>list ext
External Cache manager : Enabled
Port number           : 82
TCP timeout           : 120 seconds
```

### Example: list partition

```
WEBC Config>list part
Cache Partition 0
Maximum partition size      : 1 MB
Maximum number of objects  : Unlimited
Maximum object size       : Unlimited
Activate on reboot         : Enabled
Cache purge interval       : 10 minutes
Dynamic URL mask           : '*/cgi*'
Transparent caching        : Enabled
Check cache control headers : Disabled
Cache images               : Disabled
Cache non-image static objects : Enabled
  Default expiration time  : 60 minutes (1 hrs 0 mins)
Cache dynamic objects      : Disabled
Associated proxies (cluster port) : (113.3.1.10 80)
```

1 cache partition(s) defined.

## Configuring and Monitoring Web Server Cache

### Example: list url

```
WEBC Config>list url
Partition number [0]?
URL masks defined : 5
  1: EXCLUDE '*index*'
  2: EXCLUDE '*comp*'
  3: INCLUDE '*tmp*'
  Default expiration time: 1 minutes
  4: INCLUDE '*stat*'
  Default expiration time: 2 minutes
  5: INCLUDE '*html*'
  Default expiration time: 1000 minutes (16 hrs 40 mins)
```

## Modify

Use the **modify** command to modify the Web Server Cache information.

### Syntax:

```
modify          external
                  partition
                  proxy
                  urlmask
```

**external** Allows you to modify the External Cache Control Manager.

**partition** Allows you to modify a partition.

**proxy** Allows you to modify the proxy

**urlmask** Allows you to modify the URL mask.

### Example: modify external

```
WEBC Config>mod ext
External cache manager port number(0 to disable) [82]?
TCP connection timeout (Range 5-240) seconds [120]? 20
Do you want to modify the encryption key:? [No]? Y
Encryption key should be 16 characters long.
Encryption key (16 characters) in Hex (0-9, a-f, A-F):
Encryption Key again (16 characters) in Hex (0-9, a-f, A-F):
The external cache manager has been modified.
```

### external cache manager port number

Specifies the external cache control manager port number to be modified.

**Valid Values:** 0 to 255

**Default Value:** 82

### TCP connection timeout

Specifies the TCP connection of the external cache control manager to be modified.

**Valid Values:** 5 to 240 seconds

**Default Value:** 120

### do you want to modify the encryption key

Specifies whether or not to modify the encryption key.

**Valid Values:** yes or no

**Default Value:** no

### encryption key

The encryption key for the external cache control manager you want to modify. The encryption key must be 16 characters in length and expressed in Hex.



## Configuring and Monitoring Web Server Cache

**Valid Values:** Hex (0-9, a-f, A-F)

**Default Value:** none

**Example:** modify partition

```
WEBC Config>modify partition
Partition number [0] ?
Maximum partition size (1-255 megabytes or 0 for no limit) [0]? 200
Maximum number of objects (1-100000 or 0 for no limit)[0]? 5000
Maximum object size (512-300000 bytes or 0 for no limit)[0]? 250000
Do you want the cache enabled upon reboot? [Yes]:

Default cache purge interval (1-720 minutes or 0 to disable) [10]? 20
Enable transparent caching? [Yes]:
Check cache control headers? [Yes]:
Cache images? [Yes]:
    Default expiration time for images
        (1-10080 minutes or 0 for no expiration) [60]?
Cache non-image static objects? [Yes]:
    Default expiration time for non-image static objects
        (1-10080 minutes or 0 for no expiration) [60]?
URL mask to identify dynamic objects [*/cgi*]? *dyn*
Cache dynamic objects? [No]: y
Cache partition number 0 has been modified.
```

### **partition number**

The number of the partition to be modified.

**Valid Values:** any valid partition number

**Default Value:** 0

### **maximum partition size**

The maximum partition size of the partition to be modified. Zero specifies no limit.

**Valid Values:** 1 to 255 megabytes or 0 for no limit

**Default Value:** 0

### **maximum number of objects**

The maximum number of objects to be modified in the partition. Zero specifies no limit.

**Valid Values:** 0 to 100000 or 0 for no limit

**Default Value:** 0

### **maximum object size**

The maximum size of the object to be modified in the partition. Zero specifies no limit.

**Valid Values:** 512 to 300000 or 0 for no limit

**Default Value:** 0

### **do you want the cache enabled upon reboot**

Specifies whether or not to enable the cache after a reboot.

**Valid Values:** yes or no

**Default Value:** yes

### **default cache purge interval**

Specifies the default cache purge interval. Zero disables the default cache purge interval.

**Valid Values:** 1 to 170 minutes or 0 to disable

**Default Value:** 10

## Configuring and Monitoring Web Server Cache

### **enable transparent caching**

Specifies whether or not to enable transparent caching. The alternative is manipulating the cache with the ECCP.

**Valid Values:** yes or no

**Default Value:** yes

### **check cache control headers**

Specifies whether or not to check the cache control headers.

**Valid Values:** yes or no

**Default Value:** yes

### **cache images**

Specifies whether or not to cache images.

**Valid Values:** yes or no

**Default Value:** yes

### **Default expiration time for images**

Specifies the default expiration time for images. Zero for no expiration.

**Valid Values:** 1 to 10080, or 0 for no expiration

**Default Value:** 60

### **cache non-image static objects**

Specifies whether or not to cache non-image static objects.

**Default Value:** yes

**Valid Values:** yes or no

### **Default expiration time for non-image static objects**

Specifies the default expiration time for non-image static objects. Zero for no expiration.

**Valid Values:** 1 to 10080, or 0 for no expiration

**Default Value:** 60

### **url mask to identify dynamic objects**

Specifies the URL mask to use to identify dynamic objects.

**Valid Values:** any valid url mask

**Default Value:** \*/cgi\*

### **cache dynamic objects**

Specifies whether or not to cache dynamic objects.

**Valid Values:** yes or no

**Default Value:** no

### **Example: modify url**

```
WEBC Config>modify url
Partition number [0]?
URL masks defined : 5
  1: EXCLUDE '*index*'
  2: EXCLUDE '*comp*'
  3: INCLUDE '*tmp*'
     Default expiration time: 1 minutes
  4: INCLUDE '*stat*'
     Default expiration time: 2 minutes
  5: INCLUDE '*html*'

```

## Configuring and Monitoring Web Server Cache

```
Default expiration time: 1000 minutes (16 hrs 40 mins)
URL mask number [1] ? 4
New URL mask *stat*?
Include or Exclude from cache (i or e) [i]?
Set default expiration time? Yes :
Default expiration time
(1-10080 minutes or 0 for no expiration) [2]? 5
URL mask number 4 has been modified.
```

### **partition number**

Specifies the partition number for the URL to be modified.

**Valid Values:** any valid partition number

**Default Value:** 0

### **url mask number**

Specifies the URL mask number of the URL mask to be modified.

**Valid Values:**any valid URL mask number

**Default Value:** 1

### **new url mask \*stat\***

**Valid Values:** yes

**Default Value:** yes or no

### **include or exclude from cache**

Specifies whether or not to include in or exclude the modified URL in the cache.

**Valid Values:** i or e

**Default Value:** i

### **set default expiration time**

Specifies whether or not to set the default expiration time.

**Valid Values:** yes or no

**Default Value:** yes

### **default expiration time**

Specifies the default expiration time in minutes. Zero specifies no expiration.

**Valid Values:** 1 to 10080 minutes, or 0 for no expiration.

**Default Value:**0

---

## Accessing the Web Server Cache Monitoring Environment

To access the Web Server Cache monitoring environment enter **f webc** at the **t 5** config prompt.

```
t 5>f webc
```

### Web Server Cache Monitoring Commands

Table 19 list the Web Server Cache monitoring commands. All of the commands operate against the running system, and do not modify the configuration database. The **Activate** command uses information from the configuration.

Table 19. Web Server Cache Monitoring Commands Summary

Command	Function
? (Help)	Displays all the commands available for this command level or lists the options for specific commands (if available). See “Getting Help” on page xxxii.
Activate	Activates or reactivates cache partitions, using the latest configuration.
Clear	Clears a partition or statistics.
Enable	Enables a partition.
Delete	Deletes a partition, proxy or URL mask from the running system.
Disable	Disables a partition.
List	Lists the caching information.
Modify	Modifies the caching information.
Exit	Returns you to the previous command level. See “Exiting a Lower Level Environment” on page xxxii.

### Activate

Use the **activate** command to activate all Web Server Cache partitions or a specific partition or proxy.

**Syntax:**  
**activate**

all  
external  
partition  
proxy

**all** Activates or reactivates all defined cache partitions.

**external** Activates the External Cache Control Manager.

**partition** Activates or reactivates a partition in a cache.

**proxy** Activates or reactivates a proxy in a cache.

**Example:** activate all

```
WEBC>act all
Cache partitions, must be disabled to reactivate them.
Do you wish to continue? [No]: y
WEBC>
```

**Example:** activate Proxy

```
WEBC>act pr
1) Cluster address 113.3.1.10, Port 80, Cache partition 0
2) Cluster address 113.3.1.10, Port 81, Cache partition 0
Enter proxy number: 1 ? 1
You are trying to activate an existing proxy.
Doing this will cause the proxy to be terminated before
being reactivated.
Do you wish to continue? [No]: yes
```

### Clear

Use the **clear** command to clear a partition or statistics.

**Note:** Clearing the objects from the partition does not clear the statistics for the partition.

## Configuring and Monitoring Web Server Cache

### Syntax:

**clear** partition  
statistics

### partition

Clears all the objects out of the partition.

### statistics

Clears existing statistics for the partition.

### Example:

```
WEBC>clear partition
Enter partition number: [0]?
Cache partition 0 must be disabled to clear its contents.
Do you wish to continue? [No]: yes
Do you wish to enable this partition? [Yes]: yes
```

### partition number

Specifies the partition number to be cleared.

**Valid Values:** any valid partition number

**Default Value:** 0

## Enable

Use the **enable** command to enable a partition in the running system.

### Syntax:

**enable** partition

### Example:

```
WEBC>enable partition
Enter partition number: [0]?
```

### partition number

The partition number of the partition to be enabled.

**Valid Values:** any valid partition number

**Default Value:** 0

## Delete

Use the **delete** command to delete a partition from the running system. All proxies using the partition are deleted. No changes occur to the configuration database for either proxies or partitions.

### Syntax:

**delete** partition

### partition

Deletes a partition from the cache.

### Example:

```
WEBC>delete partition
Enter partition number: [0]? 0
WARNING: This will delete partition 0 and free all memory!
Do you wish to continue? [No] : yes
WEBC>
```

### partition number

Specifies the partition number to be deleted.

## Configuring and Monitoring Web Server Cache

**Valid Values:** any valid partition number

**Default Value:** 0

## Disable

Use the **disable** command to disable a partition in the running system.

**Syntax:**

**disable** partition

**partition**

Disables a partition.

**Example:**

```
WEBC>disable partition
Enter partition number: [0]?
```

**partition number**

Specifies the partition number of the partition to be disabled.

**Valid Values:** any valid partition number

**Default Value:** 0

## List

Use the **list** command to display the information for all Web Server Caching, a partition, a policy or a proxy.

**Syntax:**

**list** all  
delete  
depend  
external  
item  
partition  
policy  
proxy

**all** Lists all the partitions, policies, and proxies in a cache.

**delete** List the last 100 items deleted from the cache partition.

**depend**

Lists the dependency table for the partition.

**external**

Lists the information for the External Cache Control Manager.

**item**

List the current items and the hit count, in the cache partition.

**partition**

List the partition information in the cache.

**policy**

Lists the policy information in the cache.

**proxy**

Lists the proxy information in the cache.

**Example:**

```
WEBC>list all
Cache Partition 0      Status: Enabled
Cluster address: 113.3.1.10 Port 80
```

## Configuring and Monitoring Web Server Cache

```
1 partition(s) active.  
External Cache Manager Port: 82  
Connection Timeout: 120 seconds
```

### Example:

```
WEBC>list delete  
Enter partition number: [0]? 0  
Delete Table  
URL String -- hit count  
=====
```

'/abc.html' --	4
'/soccer.html' --	2
'/tennis.html' --	1
'/curling.html' --	3

### Example:

```
WEBC>list depend  
Enter partition number: [0]?  
  
Dependency table for Partition 0  
-----  
dep: tennis info  
count of URLs: 2  
URLs:  
    tennis_schedule.html  
    tennis_roster.html  
dep: soccer info  
count of URLs: 2  
URLs:  
    soccer_schedule.html  
    soccer_roster.html  
dep: roster  
count of URLs: 2  
URLs:  
    soccer_roster.html  
    tennis_roster.html  
dep: schedule  
count of URLs: 2  
URLs:  
    soccer_schedule.html  
    tennis_schedule.html
```

### Example:

```
WEBC>list item  
Enter partition number: [0]? 0  
Current number of items: 5  
URL String -- hit count  
=====
```

'/' --	2
'/file5k.html' --	1
'/file4k.html' --	1
'/file2k.html' --	3
'/file1k.html' --	1

### Example:

```
WEBC>li partition 0  
Cache Partition 0      Status: Enabled  
Cluster address: 113.3.1.10, Port 80  
Cluster address: 113.3.1.10, Port 81  
Partition size: Current - 0 bytes Highest - 0 bytes Maximum - Unlimited  
Number of objects: Current - 0 Highest - 0 Maximum - Unlimited  
Maximum object size: Unlimited  
Cache purge interval: 10 minute(s)  
Hit ratio: 0%  
Total number of hits: 0  
Cache Hit Bytes Served: 0  
Breakdown of responses for the Cache Hits  
(note: this is based on whether the HTTP Proxy considered it a hit.  
So these counts may not add up to the hit count above)  
Response 200(OK): 0  
Response 203(Non-Authoriative): 0  
Response 206(Partial Content): 0
```

## Configuring and Monitoring Web Server Cache

```
Response 300(Multiple Choices): 0
Response 301(Moved Permanently): 0
Response 304(Not Modified): 0
Response 410(Gone): 0
Total number of misses: 0
Cache Miss Bytes Served: 0
Breakdown of responses for the Cache Misses
(note: this is based on whether the HTTP Proxy got the response
back through it. In the case of multiple boxes working together
as a big cache these counts will not add up to the total misses
if a handoff was done)
Response 100 Range(Information): 0
Response 200(OK): 0
Response 200 Range(Successful-not 200): 0
Response 304(Not Modified): 0
Response 300 Range(Redirection-not 304): 0
Response 400 Range(Client Error): 0
Response 500 Range(Server Error): 0
Response other (not in above): 0
Object Excluded (Object too large): 0
                (Object expired): 0
                (DONT CACHE header): 0
                (URL Mask excluded): 0
                (Image excluded): 0
                (Static object excluded): 0
                (Dynamic object excluded): 0
                (Cache disabled): 0
Total number of objects added via ECCM Interface: 0
Total number of objects not added via ECCM Interface but was attempted: 0
Total number of objects replaced via ECCM Interface: 0
```

### Example:

```
WEBC>li po1
Enter partition number: [0]?
Transparent caching: Enabled
Cache Control Headers: Enabled
Cache images: Enabled
    Default lifetime: 0 minute(s)
Cache non-image static objects: Enabled
    Default lifetime: 0 minute(s)
Cache dynamic objects: Disabled
Dynamic URL mask: *dyn*
URL masks defined:
  1: EXCLUDE *index*
  2: EXCLUDE *comp*
  3: INCLUDE *tmp*
    Default expiration time: 1 minutes
  4: INCLUDE *stat*
    Default expiration time: 2 minutes
  5: INCLUDE *html*
    Default expiration time: 1000 minutes (16 hrs 40 mins)
```

### Example: Proxy that is part of a Scalable High Availability Cache (SHAC) array.

```
WEBC>li pr
WEBC>li pr
  1) Cluster address 113.3.3.10, Port 80, Cache Partition 0
  2) Cluster address 113.3.3.20, Port 80, Cache Partition 0
Enter proxy number: [1]? 1
Proxy 1: assigned to cache partition 0
Cluster address: 113.3.3.10 Port number: 80
Server Connection Timeout: 120 seconds
Client Connection Timeout: 120 seconds
Client connections: 0 current / 2 at highest point
Server connections: 0 current / 2 at highest point
Total cache hits: 0
Total cache misses: 649
Cache misses (object not in cache): 649
                (unsupported method): 0
                (can't send response): 0
                (non-cached request): 0
This Proxy is part of a cache group
Source IP address for group is: 113.3.3.1
There are currently 2 Cache(s) in this group
Below are the Caches in the group:
113.3.1.1
113.3.6.1
```



## Configuring and Monitoring Web Server Cache

**Example:** Proxy that is not part of the SHAC array.

```
WEBC>1i pr
  1) Cluster address 113.3.1.10, Port 80, Cache Partition 0
  2) Cluster address 113.3.1.10, Port 81, Cache Partition 0
Enter proxy number: [1]?
Proxy 1: assigned to cache partition 0
Cluster address: 113.3.1.10 Port number: 80
Server Connection Timeout: 240 seconds
Client Connection Timeout: 240 seconds
Client connections: 0 current / 0 at highest point
Server connections: 0 current / 0 at highest point
Total cache hits: 0
Total cache misses: 0
Cache misses (object not in cache): 0
              (unsupported method): 0
              (can't send response): 0
              (non-cached request): 0
              (invalidation): 0
```

## Modify

Use the **modify** command to modify the External Cache Control Manager.

**Syntax:**

**modify** external

**Example:** modify external

```
WEBC Config>mod ext
External cache manager port number(0 to disable) [82]?
TCP connection timeout (Range 5-240) seconds [120]? 20
Do you want to modify the encryption key:? [No]? Y
Encryption key should be 16 characters long.
Encryption key (16 characters) in Hex (0-9, a-f, A-F):
Encryption Key again (16 characters) in Hex (0-9, a-f, A-F):
```

**external cache manager port number**

**TCP connection timeout**

**do you want to modify the encryption key**

**encryption key**

---

## Web Server Cache Dynamic Reconfiguration Support

This section describes dynamic reconfiguration (DR) as it affects Talk 6 and Talk 5 commands.

### CONFIG (Talk 6) Delete Interface

Web Server Cache does not support the CONFIG (Talk 6) **delete interface** command.

### GWCON (Talk 5) Activate Interface

The GWCON (Talk 5) **activate interface** command is not applicable for Web Server Cache. The Web Server Cache is a feature, not an interface.

### GWCON (Talk 5) Reset Interface

The GWCON (Talk 5) **reset interface** command is not applicable for Web Server Cache. The Web Server Cache is a feature, not an interface.

## Configuring and Monitoring Web Server Cache

### GWCON (Talk 5) Component Reset Commands

Web Server Cache supports the following Web Server Cache-specific GWCON (Talk 5) **reset** commands:

#### GWCON, Feature WEBC, Activate All Command

**Description:**

This command will read all of the SRAMs for Web Server Cache and make the current runtime environment the same.

**Network Effect:**

All proxies that were currently active will be terminated (that is, all connections on those proxies will be brought down). If the External Cache Control Manager was running, the 2212 will stop listening for new connections on the current port (that is, the connections to the current port will not go down).

**Limitations:**

The Web Server Cache must have already been activated (see **CONFIG, feature webc, activate**).

All Web Server Cache commands are supported by the **GWCON, feature webc, activate all** command.

#### GWCON, Feature WEBC, Activate Partition Command

**Description:**

This command will read all of the SRAMs for this partition and make the current run time environment for the partition be the same.

**Network Effect:**

If the partition being activated already exists, all the proxies on that partition will be terminated (that is, all connections on those proxies will be brought down).

**Limitations:**

- The Web Server Cache must already have been activated (see **CONFIG, feature webc, activate**).

The following table summarizes the Web Server Cache configuration changes that are activated when the **GWCON, feature webc, activate partition** command is invoked:

Commands whose changes are activated by the GWCON, feature webc, activate partition command
CONFIG, feature webc, add urlmask
CONFIG, feature webc, delete partition
CONFIG, feature webc, delete urlmask
CONFIG, feature webc, modify partition
CONFIG, feature webc, modify proxy
CONFIG, feature webc, modify urlmask

#### GWCON, Feature WEBC, Activate Proxy Command

**Description:**

This command will read all of the SRAMs for this proxy and make the current run time environment for the proxy be the same.

## Configuring and Monitoring Web Server Cache

### Network Effect:

If the proxy being activated already exists, it will be terminated first (that is, all the connections on the proxy will be brought down).

### Limitation:

The Web Server Cache must already have been activated (see **CONFIG, feature webc, activate**).

The following table summarizes the Web Server Cache configuration changes that are activated when the **GWCON, feature webc, activate proxy** command is invoked:

Commands whose changes are activated by the <b>GWCON, feature webc, activate proxy</b> command
--

CONFIG, feature webc, modify proxy
------------------------------------

### GWCON, Feature WEBC, Activate External Port Command

#### Description:

This command will read all of the SRAMs for the External Cache Control Manager and make the current runtime environment for the External Cache Control Manager be the same.

#### Network Effect:

If the External Cache Control Manager was running, the 2212 will stop listening for new connections on the current port (that is, the connections to the current port will not go down).

#### Limitation:

The Web Server Cache must have already been activated (see **CONFIG, feature webc, activate**).

The following table summarizes the Web Server Cache configuration changes that are activated when the **GWCON, feature webc, activate external port** command is invoked:

Commands whose changes are activated by the <b>GWCON, feature webc, activate external port</b> command
--

CONFIG, feature webc, modify external
---------------------------------------

## CONFIG (Talk 6) Activate Commands

Web Server Cache supports the following CONFIG (Talk 6) **activate** commands:

### CONFIG, Feature WEBC, Activate Command

#### Description:

Dynamically changes the Web Server Cache currently running based on the current SRAM.

#### Network Effect:

All proxies that were currently active will be terminated (that is, all connections on those proxies will be brought down). If the External Cache Control Manager was running, the 2212 will stop listening for new connections on the current port (that is, the connections to the current port will not go down).

#### Limitations:

None.

## Configuring and Monitoring Web Server Cache

All Web Server Cache commands are supported by the **CONFIG, feature webc, activate** command.

### GWCON (Talk 5) Temporary Change Commands

Web Server Cache supports the following GWCON commands that temporarily change the operational state of the device. These changes are lost whenever the device is reloaded, restarted, or you execute any dynamically reconfigurable command.

Commands
GWCON, feature webc, modify external <b>Note:</b> This command will change the current run time environment for the External Cache Control Manager. If the External Cache Control Manager was running, the 2212 will stop listening for new connections on the current port (that is, the connections to the current port will not go down).
GWCON, feature webc, delete partition <b>Note:</b> This command will delete the partition from the current runtime environment.

---

## Chapter 13. Configuring and Monitoring the Encoding Subsystem

Data compression and encryption functions are grouped together in the Encoding Subsystem (ES). ES provides access to the encoding devices for interfaces or protocols and is automatically activated whenever a link is activated for compression or encryption. On the 2212 platform, the encoding devices are the Compression/Encryption Adapter (CEA) and the software device. The software device consists of operational software that performs compression and encryption. When the software device is used, the compression and encryption algorithms are run on the router's processor. You do not need to change the default configuration to use the CEA or the software device.

Monitoring the ES activity can be done by entering **feature es** from the monitoring (talk 5) prompt.

The ES configuration parameters allow you to limit the amount of memory used by the ES software device. The default configuration allows the ES to get as much memory as required. To limit memory usage, use the **set** command under **feature es** in the configuration process (Talk 6).

This chapter consists of the following sections:

- "Configuring the Encoding Subsystem"
- "Monitoring the Encoding Subsystem" on page 221
- "Encoding Subsystem Dynamic Reconfiguration Support" on page 225

---

### Configuring the Encoding Subsystem

The ES configuration parameters provide a way to control the number of compression and encryption sessions that are using the software encoding device at one time. The software encoding device is essentially a collection of compression and encryption libraries that are run on the router's processor. A session consists of a full-duplex connection over a particular interface that has been configured to use compression or encryption.

**Note:** The ES configuration parameters influence only the software encoding device, not the CEA.

Generally, data encoding is a processor-intensive operation. By limiting the number of software encoding sessions, the impact of data encoding on the performance of the router can be controlled to a certain extent. As an example, if the router has 20 dial-in interfaces configured for compression and it has been determined that compressing more than 10 interfaces at once has an adverse effect on the performance of the router, the maximum number of compression sessions should be set to 10. This allows any 10 of the 20 interfaces to use compression.

The memory requirements of the software encoding device may also be a reason to limit the number of sessions. Each software compression session uses approximately 30 KB of router memory and an encryption session uses approximately 2 KB. If too much memory is used by the ES, other functions may become memory-restricted and the router's performance can be adversely affected. See "Considerations" on page 230 for more information.

## Configuring ES

You can set the minimum or maximum number of ES sessions by stating the number of sessions or by specifying one of the values *unlimited*, *default*, or a number. The values *unlimited* and *default* have the same meaning; these values allow the router to support all the sessions that have been activated for encryption or compression, until the memory is exhausted.

**Note:** None of the ES configuration parameters (talk 6) can be dynamically reconfigured. To activate parameter values after you have changed them, you must restart or reload the router.

In the Config process (talk 6), enter **feature es** at the Config> prompt to access the ES configuration commands. The ES Config> prompt appears. Table 20 lists the commands.

Table 20. ES Configuration Commands

Command	Action
? (Help)	Displays all the commands available for this command level or lists the options for specific commands (if available). See “Getting Help” on page xxxii.
List	Displays the current setting of compression and encryption sessions.
Set	Sets the maximum number of encryption and compression sessions available for all interfaces.
Exit	Returns you to the previous command level. See “Exiting a Lower Level Environment” on page xxxii.

## List

Use the **list** command to display the current setting of the compression and encryption sessions.

### Syntax:

**list**

### Example:

```
ES Config> list
Data Compression and Encryption System Configuration
-----
Parameters used for host-based encoding:
Compression sessions:
  Reserved at initial bootup:          0
  Maximum allowed:                    unlimited
Encryption sessions:
  Reserved at initial bootup:          0
  Maximum allowed:                    unlimited
```

## Set

Use the **set** command to set the maximum number of data encryption or compression sessions.

### Syntax:

```
set sw minimum compression-sessions n, unlimited, or default
sw maximum compression-sessions n, unlimited, or default
```

*sw* minimum encryption-systems *n*, *unlimited*, or *default*

*sw* maximum encryption-systems *n*, *unlimited*, or *default*

**Note:** The letters *sw* are an abbreviation for software.

**software minimum compression-sessions** *n*, *unlimited*, or *default*

Sets the minimum number of compression sessions available for the interfaces. The router reserves this many sessions so that they are always available.

**Default Value:** 0

**Valid Values:** 0 to *unlimited*; alternatively, *default*

**software maximum compression-sessions** *n*, *unlimited*, or *default*

Sets the maximum number of compression sessions available for the interfaces. Once this number of sessions has been activated, new sessions cannot be activated.

**Default Value:** 0

**Valid Values:** 0 to *unlimited*; alternatively, *default*

**software minimum encryption-sessions** *n*, *unlimited*, or *default*

Sets the minimum number of encryption sessions available for the interfaces. The router reserves this number of sessions so that they are always available.

**Default Value:** 0

**Valid Values:** 0 to *unlimited*; alternatively, *default*

**software maximum encryption-sessions** *n*, *unlimited*, or *default*

Sets the maximum number of encryption sessions available for the interfaces. Once this number of sessions has been activated, new sessions cannot be activated.

**Default Value:** 0

**Valid Values:** 0 to *unlimited*; alternatively, *default*

---

## Monitoring the Encoding Subsystem

In the monitoring process, enter **feature es** at the + prompt to access the ES monitoring commands. The ES Monitor> prompt appears. Table 21 lists the available commands.

*Table 21. ES Monitoring Command*

Command	Action
? (Help)	Displays all the commands available for this command level or lists the options for specific commands (if available). See “Getting Help” on page xxxii.
List	Lists ES ports, circuits, devices, configuration, status, or summary.
Exit	Returns you to the previous command level. See “Exiting a Lower Level Environment” on page xxxii.

## Monitoring ES

### List

Use the **list** command to list information about ES. See the **list summary** command for an example of the output of the **list** command that includes ports, devices, and status.

#### Syntax:

```
list                ports
                    circuits
                    develop
                    config
                    status
                    summary
```

**ports** The **list ports** command lists the encoding ports that have been created by potential clients of the encoding system. A port establishes a linkage between the encoding system and the clients that have been configured to use ES. For example, if compression or encryption is configured over the PPP interface Net 1, a port is associated with that interface. The QLen field shows the sum of all the outstanding compression or encryption requests for all of the circuits associated with the port. A client, such as PPP configured over a particular interface, presents a request to ES when it designates a particular buffer of data for encoding.

The Status field shows *Idle* if nothing is queued at the port, or *Busy* or *Waiting* if requests are in process or queued on the port.

#### circuits

The **list circuits** command displays the circuits that have been defined by clients of the encoding system. Each circuit corresponds to a full-duplex connection. Data encrypted or compressed at one endpoint is decrypted or decompressed at the other.

By default, only active circuits are displayed. Use the command **list circuits all** to include both active and inactive circuits.

For each circuit found, the port and user are displayed as in the **list ports** command. In addition, two lines of information are shown, a Tx line for the outbound circuit and an Rx line for the inbound circuit. The circuit ID is an arbitrary number provided by the client so that it can tag each circuit that it creates. For Frame Relay circuits, this number corresponds to the ID of the associated Frame Relay data-link circuit (DLCI). Point-to-Point links create only one circuit, which is always identified by the number 1.

In addition, the following items are displayed:

**Dev** This is the number that represents the encoding device that is servicing that stream. It is 1 when the encoding is being done by software activating the CPU and 2 when the encoding is being done by the compression/encryption adapter.

**Cmpr** This field displays the compression or decompression algorithm active for that stream. If it is *LZC*, STAC-LZC compression is being used; if it is *MPPC*, Microsoft® PPC is used. An asterisk (\*) is appended to the name of the algorithm if the stream is operating in stateless mode. Stateless mode is a mode in which the history of the data packet is not maintained after that packet has been



processed, as opposed to continuous mode in which history is maintained from handling one packet in order to handle the next. For example, in continuous compression, the encoder maintains a cache of information gathered from previous packets in order to more effectively compress the current packets.

- Encr** This field displays the encryption or decryption algorithm being used. It is *DES* for standard DES, *3DES* for Triple DES, or *RC4* if RSA's RC4 algorithm is used. An asterisk (\*) is appended to the name if the stream is operating in stateless mode. This is significant for RC4 but means little for DES/3DES. Note that the name shown corresponds to the basic encryption algorithm employed, not to the encapsulation format used by the client. For example, PPP supports two encapsulation methods: DESE (RFC 1969) which encrypts with DES, and MPPE (Microsoft nonstandard), which uses RC4.
- QLen** This parameter shows the number of outstanding packets sitting in the stream's queue waiting to be encoded or decoded. Note that this number only reflects packets that have actually been submitted to ES for processing. Some clients may keep their own queues and feed only a few packets at a time to the encoding system from these private queues.

#### Status

A quick indication of the stream's status. It is not unusual for all streams to have a waiting status and none to appear to be busy. Seeing a busy status requires catching the queue activity during a fairly narrow window of time in the processing cycle. These are the possible states:

**Idle** No packets are queued on this stream

**Busy** The system is currently processing packets on this stream (meaning that the item at the head of the queue is going through the encoding engine at that moment).

#### Waiting

Requests are pending, but nothing from that stream is currently undergoing processing.

#### devices

The **list devices** command lists the encoding devices that the system has available to it. An encoding device usually refers to a compression/encryption adapter. The software that is used when a hardware accelerator is not available is implemented as a virtual device and will also show up in this list as a *Host Software* device. There are two forms for this command: **list devices** and **list device n**. The first form produces a short summary listing of all the devices recognized by the system. The second form will produce a detailed listing for a specific device n, where n is the unit number. Unit 1 represents host software, which is a virtual encoding device, and unit 2 represents the compression/encryption adapter. An asterisk (\*) can be used in place of the number n, in which case a listing is provided for both units.

**config** The **list config** command displays the current configuration parameters. These are the parameters read from the non-volatile memory at the time that the router is restarted or reloaded. The information displayed is identical to that displayed by the configuration (Talk 6) **list config** command.

## Monitoring ES

**status** The **list status** command displays the encoding system status, which consists of some global status flags and some miscellaneous system statistics. These are the descriptions of the fields that are displayed by the **list status** command:

### Last Error

The last error code returned to any client of the encoding system. This is meant for debugging and should be used by service personnel.

### Internal Condition flags

This field shows certain internal conditions, as defined in the following list:

**Ready** The system is up and operational. This is the normal condition.

### Not Working

The encoding system is inoperative due to some internal error.

### No Devices Available

Indicates that no device is available to do the encoding. This condition should not occur because if a hardware-based encoder is not present, encoding is accomplished by internal software.

### Out of Memory

The system tried to allocate memory and failed. This condition indicates that the router is low on RAM and that the encoding system has been adversely affected.

### Number of Ports

This field indicates the number of clients that have established ports for themselves in the ES. See the **list ports** command for a definition of a port.

### Number of Circuits

See the **list circuits** command for a definition of circuits.

### Global Request pool size

The number of request buffers allocated and free. Roughly one request buffer is used for each packet that is encoded. If the number of buffers free is smaller than the number allocated, encoding is in process.

### Total # of Requests processed

This value shows the total number of buffers that have been processed by the encoding engine. This number corresponds roughly to the total number of packets that have been compressed or encrypted by all the clients of the system since the last router restart or reload.

### summary

This command displays a summary of the system. It is a composite command that combines the output from the **list status**, **list devices**, and **list ports** commands.

### Example:

```
list summary
Encoding System Status
-----
```

```

Last Error:                               14 (Stream not active)
Internal Condition flags:                   0x00000001 -->
                                             Ready
Number of Ports:                           2
Global Request pool size:                   Alloc: 32 Free: 32
Total # of Requests processed:              7059

```

```

                                Encoding System Devices
Encoding System Devices
Device Type                        Slot/Port  Status
-----
  2 Hardware Accelerator/0         2/1      Ready
  1 Host Software                   0/0      Ready
  0 Null Device                     0/0      Ready

```

```

                                Encoding System Ports
-----
Port  User                        +--Encoder State--+ +--Decoder State--+
      (PPP/0)                    QLen  Status         QLen  Status
-----
  1 Net 2 (PPP/0)                 0 Idle              0 Idle
  2 Net 3 (PPP/1)                 0 Idle              0 Idle

```

---

## Encoding Subsystem Dynamic Reconfiguration Support

This section describes dynamic reconfiguration (DR) as it affects Talk 6 and Talk 5 commands.

### CONFIG (Talk 6) Delete Interface

Encoding Subsystem does not support the CONFIG (Talk 6) **delete interface** command.

### GWCON (Talk 5) Activate Interface

The GWCON (Talk 5) **activate interface** command is not applicable for Encoding Subsystem. The ES configuration parameters determine how much memory will be allocated for the ES at boot time and is not associated with an interface.

### GWCON (Talk 5) Reset Interface

The GWCON (Talk 5) **reset interface** command is not applicable for Encoding Subsystem. The ES configuration parameters determine how much memory will be allocated for the ES at boot time and is not associated with an interface.

## Non-Dynamically Reconfigurable Commands

Encoding Subsystem does not support dynamic changes of any of its configuration parameters.

## Monitoring ES

---

## Chapter 14. Configuring and Monitoring Data Compression

This chapter discusses data compression on a 2212 over Frame Relay and PPP interfaces. It includes the following sections:

- “Data Compression Overview”
- “Data Compression Concepts”
- “Configuring and Monitoring Data Compression on PPP Links” on page 232
- “Configuring and Monitoring Data Compression on Frame Relay Links” on page 234

Data compression is supported on Frame Relay and PPP interfaces.

---

### Data Compression Overview

The data compression system provides a means to increase the effective bandwidth of networking interfaces on the device. It is primarily intended for use on slower speed WAN links.

Data compression on the device is supported on PPP and Frame Relay interfaces.

- For PPP interfaces, compression is implemented according to the Compression Control Protocol (CCP) as defined in the Internet Engineering Task Force’s RFC 1962. CCP provides the underlying mechanisms by which the use of compression is negotiated and a means for choosing among multiple possible compression protocols.

The device provides two compression protocols: the Stac-LZS protocol, defined in RFC 1974; and the Microsoft Point-to-Point Compression protocol (MPPC), described in RFC 2118. Both of these are based on compression algorithms provided by Stac Electronics.

- For Frame Relay interfaces, compression is implemented according to FRF.9, the *Data Compression over Frame Relay Implementation Agreement* produced by the Frame Relay Forum Technical Committee. FRF.9 describes a Data Compression Protocol (DCP), modeled after PPP’s CCP, and similarly provides a means for negotiating various compression algorithms and options. The device supports DCP “mode 1” negotiation. FRF.9 also describes a more generalized “mode 2”; this is not supported. Compression itself is done using the same compression engine as used for the PPP Stac-LZS protocol.

---

### Data Compression Concepts

Data compression on the device provides a means to increase throughput on network links by making more efficient use of the available bandwidth on a link. The basic principle behind this is simple: represent the data flowing across a link in as compact a manner as possible so that the time needed to transmit it is as low as possible, given a set speed on a link.

Data compression may be performed at many layers in the networking model. At one end of the spectrum, applications may compress data prior to transmitting it to peer applications elsewhere in the network, while at the other end of the spectrum devices may be performing compression at the data link layer, working purely on the bit stream passing between two nodes. How this compression is done and how effective it is depends on a variety of factors, including such things as what network layer the compression is performed at, how much intrinsic knowledge the compressor and decompressor have about the data being compressed, the compression algorithm chosen, and the actual data being compressed. The best

## Configuring and Monitoring Data Compression

compression can usually be performed at the application layer; for example, a file transfer application usually has the luxury of having an entire file of data available to it prior to attempting compression, and it may be able to try different compression algorithms on the file to see which performs best on that particular file's data. Although this may provide excellent compression for that one type of application, it does little to solve the general problem of compressing the bulk of the traffic flowing over a network, as most networking applications do not currently compress data as they generate it.

Compression on the device takes place at a much lower networking layer, at the data link layer. In the device, compression is performed on the individual packets which are transmitted across a link. The compression is done in real-time as packets flow through the device: the sender compresses a packet just prior to transmitting it, and the decompressor decompresses the packet as soon as it receives it. This operation is transparent to the higher layer networking protocols.

## Data Compression Basics

Data compressors work by recognizing “redundant” information in data, and producing a different set of data which contains as little redundancy as possible. “Redundant” information is any information which can be derived and recreated based on the currently available data. For example, a compressor might function by recognizing repeated character patterns in a data stream and replacing these repeated patterns with a shorter code sequence to represent that pattern. As long as the compressor and decompressor agree on what these code sequences are then the decompressor can always recreate the original data from the compressed data.

This mapping of sequences in the original data to corresponding sequences in the compressed output is commonly called a **data dictionary**. These dictionaries may be statically defined - experienced-based information available to the compressor and decompressor - or they may be dynamically generated, usually based on the information being compressed. Static dictionaries are most applicable to environments where the data being processed is of a limited, known nature, and not very effective for general-purpose compressors. Most compression systems use dynamic dictionaries, including any compressors used on the device. On a 2212 the data dictionaries are based on the current packet being processed and possibly previously seen packets, but there is no ability to “look ahead” in the data stream as may exist when compression is performed at other layers. For systems where the data dictionary is dynamically derived and based only on previously seen data, the dictionary is also commonly known as a **history**. The terms history and data dictionary will be used interchangeably throughout the remainder of this chapter, though it should be understood that in other environments a history is a specific form of data dictionary.

The fact that the device uses dynamic dictionaries and that the compressor and decompressor must keep their dictionaries in synchronization means that data compression works on a stream of data passing between two endpoints. Hence, compression on the router is a connection-oriented process, where the endpoints of the connection are the compressor and decompressor themselves. When compression is started on the stream, both ends reset their data dictionaries to some known starting state, and then they update that state as data is received.

Compression could be performed on each individual packet, resetting the histories prior to processing each packet. Normally though, the data dictionaries are not reset between packets, which means that the histories are based not only on the

## Configuring and Monitoring Data Compression

contents of the current packet, but also the contents of previously seen packets. This usually improves the overall compression effectiveness, because it increases the amount of data which the compressor searches looking for redundancy to remove. As an example, consider the case of one host “pinging” another host with IP: a series of packets is sent out, each one usually nearly identical to the last one sent. The compressor may have little luck compressing the first packet, but it may recognize that each subsequent packet looks very much like the last one sent, and produce highly compressed versions of those packets.

Because the compressor and decompressor histories change with each packet received, the compression mechanisms are sensitive to lost, corrupted, or reordered packets. The compression protocols employed by the device include signaling mechanisms whereby the compressor and decompressor can detect loss of synchronization and resynchronize to each other, such as might be necessary when a packet is lost due to a transmission error. Typically this is done by including a sequence number in each packet which the decompressor will check to make sure it is receiving all packets, in order. If it detects an error, it will reset itself to some known starting state, signal the compressor to do likewise, and then wait (discarding incoming compressed packets) until the compressor acknowledges that it has also reset itself.

Compression on a link typically is performed on data going in both directions over the link. Normally, each end of a connection has both a compressor and decompressor running on it, communicating with their analogs at the other end of the connection, as shown in Figure 21 on page 230. The output (compression) side runs independently of the input (decompression) side. It is possible for completely different compression algorithms to be operating for each direction of the link. When a link connection is established, the compression control protocol for the link will negotiate with the peer to determine the compression algorithms used for the connection. If the two ends cannot agree on compression protocols to use, then no compression will be performed and the link will operate normally - packets will simply be sent in uncompressed form.

## Configuring and Monitoring Data Compression

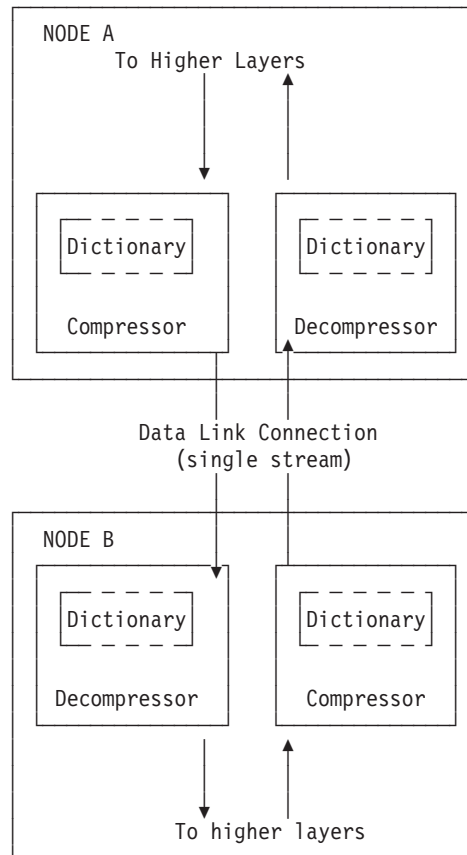

Figure 21. Example of Bidirectional Data Compression with Data Dictionaries

A stream really represents a connection between a specific compression process on one end of a link and an associated decompression process on the other end of a link, and thus is more specific than just a “connection” between two nodes; it is possible that a sophisticated compression protocol could split the data flowing between two hosts into multiple streams, compressing each of these streams independently. For example, PPP’s CCP has the ability to negotiate the use of multiple histories over a single PPP link, though the router does not support this.

## Considerations

The choice of whether or not to use data compression is not always an easy one. There are several factors which should be considered before enabling compression on a connection.

### CPU Load

Data compression is a computationally expensive procedure. As the amount of data being compressed increases (per unit time), the more of a load is put on the device’s processor. If the load becomes too great, the performance of the device degrades - on all network interfaces, not just the ones where compression is being performed.

The device actually contains multiple processors and uses asymmetric multiprocessing - for example, link I/O controllers which operate in tandem with the main processor - so the effect of the processor loading is not always readily measured. Because the compression operation may be overlapped with the



## Configuring and Monitoring Data Compression

transmission of packets, this loading may in fact be totally transparent and pose no problem. Nonetheless, it is possible to overburden the device's processor and degrade performance.

As a general rule of thumb, compression should only be enabled on slow speed WAN links - probably only for links with speeds up to about 64 kbps (the speed of a typical ISDN dial link). The total bandwidth for data being compressed on all links probably should be limited to several hundred kbps. Running compression on all channels of an ISDN Primary Rate adapter would be unwise.

The Encoding Subsystem parameters allow you to limit the number of connections which may be concurrently running compression. More interfaces can be enabled for compression than are actually running it. Once the limit on the number of active compression connections is reached, additional connections will simply not negotiate the use of compression, at least not until an existing compression link shuts down.

### Memory Usage

Another issue to consider when configuring compression is the memory requirement. Compression and decompression histories occupy a fair amount of memory, which is a limited resource in the device. The Stac-LZS algorithm for example requires about 16 KB for a compression history, and about 8 KB for a decompression history. This problem is magnified by the fact that these histories must exist for each connection which is established: a compression history is synchronized with a corresponding decompression history in a peer router. For a PPP link, this implies one compression history and one decompression history (assuming that data compression is running bidirectionally on the link). On a Frame Relay link, there could be many such histories required, one pair for each virtual connection (DLCI) which is established.

The device creates a pool of compression and decompression histories when it boots. These are always allocated in pairs known as **compression sessions** - a session is simply one compression history coupled with one decompression history. Technically, compression and decompression are independent functions, but in practice compression is almost always run bidirectionally and so memory is managed and configured in terms of sessions rather than individual histories as a way of simplifying operation. Since different compression algorithms have different memory requirements for compression and decompression, the session is sized to approximately 30 KB to handle the worst case. The pool of compression sessions is populated as configured in the Encoding Subsystem feature. See "Chapter 13. Configuring and Monitoring the Encoding Subsystem" on page 219 for details.

Whenever the device attempts to establish a compression connection on a link, it begins by reserving a session from the allocated pool of sessions. If no sessions are available, then compression is not performed on that connection. The router may attempt to start compression on that connection later as sessions become available.

The number of compression sessions which are allocated is a configurable parameter. Setting the number of sessions allocated limits both the amount of memory used and the maximum number of connections which may be simultaneously operating with compression. Limiting the number of simultaneously operating compression connections provides a means to help control the CPU loading problem.

## Configuring and Monitoring Data Compression

### Data Content

The actual nature of the data being transmitted on a connection should be considered before enabling compression for that connection. Compression works better on some types of data than others. Packets which contain a lot of nearly identical information - for example a set of packets generated from an IP "ping" - will normally compress extremely well. A typical assortment of random text and binary data going over a link will usually compress in ratios around 1.5:1 to 3:1. Some data simply will not compress well at all. In particular, data which has already been compressed will seldom compress further. In fact, data which has been previously compressed may actually expand when fed through the compression engine.

If it is known in advance that most of the data flowing over a connection will consist of compressed data, then it is recommended that compression not be enabled for that connection. An example where this might occur is a connection to a host which was set up to be primarily a FTP file archive site, where all the files available to be transferred are stored in compressed form on the host.

### Link Layer Compression

A final factor to consider is the nature of the network link between the two hosts. Compression could be performed at a lower layer than even the device's hardware interfaces. In particular, many modern modems incorporate data compression mechanisms in their hardware and firmware. If compression is being performed on the link at a lower layer (outside the device), then it is best not to enable data compression on the device for that interface. As already mentioned, compressing an already compressed data stream is normally ineffective, and in fact may degrade performance slightly. Unless there is some particular reason to believe that the router will do a much better job of compression than the link hardware, it is best to let the link hardware do the compression.

---

## Configuring and Monitoring Data Compression on PPP Links

The 2212 uses the PPP Compression Control Protocol (CCP) to negotiate the use of compression on a link. CCP provides a generalized mechanism to negotiate the use of a particular compression protocol, possibly even using a different protocol in each direction of the link, and various protocol-specific options. The software supports the Stac-LZS and MPPC protocols, so the peer must also provide support for at least one of these algorithms to successfully negotiate data compression between the two nodes. The two nodes must also agree on the algorithm-specific options for compression to operate.

### Configuring Data Compression on PPP Links

To configure data compression on PPP links:

1. Enable the CCP protocol on the link with the **enable ccp** command. This enables the link to negotiate compression with the other node. Negotiation includes what compression algorithm to use and any protocol-specific options.
2. Select which compression algorithms may be negotiated using the **set ccp algorithms** command.
3. Set the negotiable parameters for each compression algorithm using the **set ccp options** command.

You can display the current compression configuration using the **list ccp** command.

Table 22 on page 233 lists the available commands and Figure 22 on page 233 is an example of configuring compression on a PPP link. For detailed descriptions of

## Configuring and Monitoring Data Compression

these commands, see 'Point-to-Point Configuration Commands' in *Access Integration Services Software User's Guide*.

Table 22. PPP Data Compression Configuration Commands

Data Compression Command	Action
disable ccp	Disables data compression.
enable ccp	Enables data compression.
set ccp options	Sets options for the compression algorithm.
set ccp algorithms	Specifies a prioritized list of compression algorithms.
list ccp	Displays compression configuration.

```
Config>net 6 1
PPP 6 Config>enable ccp
PPP 6 Config>set ccp alg 2
Enter a prioritized list of compression algorithms (first is preferred),
all on one single line.
Choices (can be abbreviated) are:
STAC-LZS MPPC
Compressor list [STAC-LZS]? stac mppc
PPP 6 Config>set ccp options
STAC: check mode (0=none, 1=LCB, 2=CRC, 3=Seq, 4=Ext) [3]?
STAC: # histories [1]?
PPP 6 Config>li ccp

CCP Options
-----
Data Compression enabled
Algorithm list: STAC-LZS MPPC
STAC histories: 1
STAC check_mode: SEQ

MPPE Options
-----
MPPE disabled
Optional encryption
Key generation: STATEFUL
```

Figure 22. Example of Configuring Compression on a PPP Link

### Notes:

1. The network command selects the network interface for the PPP link. If the link is a PPP dial circuit, you must then use the **encapsulator** command to access the PPP configuration menu.
2. If you enable CCP and do not set algorithms for the link, the software automatically sets the link to use protocols STAC and MPPC as if you had entered the command **set ccp algorithms stac mppc**.  
If you set multiple algorithms, the order of the algorithms determines the negotiation preference for the link.  
If you enter **set ccp algorithms none**, the software will automatically disable compression on the link.  
If MPPE is enabled and CCP is enabled, MPPC is the compression algorithm.

## Monitoring Data Compression on PPP Links

You monitor compression as you would other PPP components. 'Accessing the Interface Monitoring Process' in *Access Integration Services Software User's Guide* describes how to access the PPP console environment and details about the commands. Table 23 on page 234 lists the compression-related commands. Figure 23 on page 234 shows an example of listing compression on a PPP interface.

## Configuring and Monitoring Data Compression

Table 23. PPP Data Compression Monitoring Commands

Command	Function
<b>list control ccp</b>	Lists CCP state and negotiated options.
<b>list ccp</b>	Lists CCP packet statistics.
<b>list cdp</b> or <b>list compression</b>	Lists compressed datagram statistics.

```
+ network 1
PPP > list control ccp

CCP State:           Open
Previous State:     Ack Sent
Time Since Change:  2 minutes and 52 seconds

Compressor:  STAC-LZS histories 1, check_mode SEQ
Decompressor: STAC-LZS histories 1, check_mode SEQ
MPPE:        Not negotiated

PPP > list ccp

CCP Statistic          In              Out
-----
Packets:               2              3
Octets:                18             27
Reset Reqs:            0              0
Reset Acks:            0              0
Prot Rejects:         1              -

PPP > list cdp

Compression Statistic  In              Out
-----
Packets:               19541          19542
Octets:                2550673       2740593
Compressed Octets:     821671        899446
Incompressible Packets: 0              0
Discarded Packets:     0              -
Prot Rejects:          0              -
Compression Ratios:    3.11           3.24
```

Figure 23. Monitoring Compression on a PPP Interface

---

## Configuring and Monitoring Data Compression on Frame Relay Links

After configuring the global compression parameters and enabling compression on the interface, you must then set the parameters for each individual circuit (PVC) on the Frame Relay interface. Each circuit defined for the interface may have compression enabled on the circuit, and each circuit which successfully negotiates the use of compression uses one compression session from the global pool. You can also disable compression on the interface which means none of the circuits on that interface will be eligible to carry compressed data traffic.

### Configuring Data Compression on Frame Relay Links

To configure data compression on FR links:

1. Enable compression on the interface using the **enable compression** command. This enables the link to negotiate compression with the other node.
2. Enable compression on each new PVC that will carry compressed data with the **add permanent-virtual-circuit** command. You can change existing PVCs using the **change permanent-virtual-circuit** command.

You can display the current compression configuration using the **list lmi** or **list permanent-virtual-circuit** commands.

## Configuring and Monitoring Data Compression

Table 24 lists the commands available for configuring compression on a Frame Relay link and Figure 24 is an example of configuring a Frame Relay Link. See "Frame Relay Configuration Commands" in *Access Integration Services Software User's Guide* for details.

```

Config> net 2

Frame Relay user configuration

FR Config> enable compression
Maximum number of run-time compression circuits (zero means no limit) [0]? 0
Do you want orphan PVCs to perform compression [Y]? n
The number of currently defined non-compression PVCs is 4
Would you like to change them all to compression PVCs [N]? y

FR Config> add perm

Circuit number [16]? 22
Committed Information Rate (CIR) in bps [65536]?
Committed Burst Size (Bc) in bits [64000]?
Excess Burst Size (Be) in bits [0]?
Assign circuit name []? cir22
Is circuit required for interface operation [N]?
Do you want to have data compression performed [Y]?

FR Config>list lmi

                                Frame Relay Configuration

LMI enabled          = No    LMI DLCI              = 0
LMI type            = ANSI  LMI Orphans OK        = Yes
CLLM enabled        = No    Timer Ty seconds      = 11

Protocol broadcast  = Yes   Congestion monitoring  = Yes
Emulate multicast   = Yes   CIR monitoring         = No
Notify FECN source  = No    Throttle transmit on  = No
                                FECN

Data compression    = Yes   Orphan compression    = No
Compression PVC limit = None  Number of compression PVCs = 2

PVCs P1 allowed     = 64   Interface down if no PVCs = No
Timer T1 seconds    = 10   Counter N1 increments   = 6
LMI N2 error threshold = 3   LMI N3 error threshold window = 4
MIR % of CIR        = 25   IR % Increment          = 12
IR % Decrement      = 25   DECnet length field     = No
Default CIR         = 65536 Default Burst Size      = 64000
Default Excess Burst = 0

FR Config>list perm

Maximum PVCs allowable = 64
Total PVCs configured  = 2

-----
Circuit      Circuit      Circuit      CIR      Burst      Excess
Name         Number     Type        in bps   Size      Burst
-----
cir16        16        @ Permanent 65536    64000     0
cir22        22        @ Permanent 65536    64000     0
-----

* = circuit is required
# = circuit is required and belongs to a required PVC group
@ = circuit is data compression capable

```

Figure 24. Example of Configuring Compression on a Frame Relay Link

Table 24. Data Compression Configuration Commands

Command	Action
<b>add permanent-virtual-circuit #</b>	Use to enable data compression on a specific PVC defined on an interface.
<b>change permanent-virtual-circuit #</b>	Use to change whether a specific PVC will compress data.

## Configuring and Monitoring Data Compression

Table 24. Data Compression Configuration Commands (continued)

Command	Action
<b>disable compression</b>	Disables data compression.
<b>enable compression</b>	Enables data compression.
<b>list lmi</b>	Displays the current configuration of the interface.
<b>list permanent</b>	Lists summary information about circuits.

**Note:** Enabling compression on orphan circuits will decrease the number of available compression sessions available for the native PVCs on the device.

If you enable compression on a Frame Relay interface that already has compression enabled, the software asks you if you want to change compression parameters on the interface, as shown in the following example. You can change compression on the interface without disabling compression.

### Example of changing compression on Frame Relay interfaces:

```
Config> net 2
Frame Relay user configuration
FR Config> enable compression
Data compression already enabled.
Do you wish to continue and change an interface parameter [Y]
Maximum number of run-time compression PVCs (zero means no limit) [0]? 32
Do you want orphan circuits to perform compression [Y]?
The number of currently defined circuits is 5
Change all of these circuits to perform compression?
```

## Monitoring Data Compression on Frame Relay Links

You monitor compression as you would other Frame Relay components. “Frame Relay Monitoring Commands” in *Access Integration Services Software User’s Guide* describes how to access the Frame Relay console environment and details about the commands. Table 25 lists the compression-related commands. “Example: Monitoring Compression on a Frame Relay Interface or Circuit” shows an example of listing compression on a Frame Relay interface.

Table 25. Frame Relay Data Compression Monitoring Commands

Command	Display
<b>list lmi</b>	Lists the current status of the interface.
<b>list permanent</b>	Lists summary information about circuits.
<b>list circuit</b>	Lists the current status of a circuit.

### Example: Monitoring Compression on a Frame Relay Interface or Circuit

```
+ network 2
FR 2 > list lmi

Management Status:
-----
LMI enabled          = No   LMI DLCI           = 0
LMI type             = ANSI LMI Orphans OK = Yes
CLLM enabled         = No

Protocol broadcast   = Yes  Congestion monitoring = Yes
Emulate multicast    = Yes  CIR monitoring        = No
Notify FECN source   = No   Throttle transmit on FECN = No
PVCs P1 allowed      = 64  Interface down if no PVCs = No
Line speed (bps)     = 64000 Maximum frame size    = 2048
Timer T1 seconds     = 10   Counter N1 increments = 6
LMI N2 threshold     = 3    LMI N3 threshold window = 4
```

## Configuring and Monitoring Data Compression

```

MIR % of CIR           = 25  IR % Increment           = 12
IR % Decrement         = 25  DECnet length field      = No
Default CIR            = 65536 Default Burst Size     = 64000
Default Excess Burst   = 0
  
```

```

Current receive sequence = 0
Current transmit sequence = 0
Total status enquiries   = 0  Total status responses = 0
Total sequence requests  = 0  Total responses         = 0
  
```

```

Data compression enabled = Yes  Orphan Compression = No
Compression PVC limit    = None  Active compression PVCs = 1
  
```

PVC Status:

-----

```

Total allowed = 64  Total configured = 1
Total active  = 1  Total congested = 0
Total left net = 0  Total join net  = 0
  
```

FR 2 > **list permanent**

Circuit Number	Circuit Name	Orphan Circuit	Type/State	Frames Transmitted	Frames Received
16	circ16	No	@ P/A	58364	58355
22	circ22	No	& P/A	58364	58355

A - Active    I - Inactive    R - Removed    P - Permanent    C - Congested  
 \* - Required                    # - Required and belongs to a PVC group  
 @ - Data compression capable but not operational  
 & - Data compression capable and operational

FR 2 > **list circuit 22**

Circuit name = circ22

```

Circuit state           = Active  Circuit is orphan      = No
Frames transmitted     = 58391  Bytes transmitted     = 2676894
Frames received        = 58383  Bytes received        = 2671009
Total FECNs            = 0      Total BECNs           = 0
Times congested       = 0      Times Inactive        = 0
CIR in bits/second    = 65536  Potential Info Rate   = 64000
Committed Burst (Bc)  = 64000  Excess Burst (Be)    = 0
Minimum Info Rate     = 16000  Maximum Info Rate    = 64000
Required               = No      PVC group name        = Unassigned
  
```

```

Compression capable    = Yes    Operational           = Yes
R-R's received         = 0      R-R's transmitted    = 0
R-A's received         = 0      R-A's transmitted    = 0
R-R mode discards     = 0      Enlarged frames      = 0
Decompress discards   = 0      Compression errors    = 0
Rcv error discards    = 0
  
```

```

Compression ratio      = 1.00 to 1  Decompression ratio = 1.00 to 1
  
```

```

Current number of xmit frames queued = 0
Xmit frames dropped due to queue overflow = 0
  
```

## Configuring and Monitoring Data Compression



---

## Chapter 15. Using Local or Remote Authentication

Authentication is the process of determining who a user (or entity) is. Authenticating user access for the PPP protocol on the 2212 extends the flexibility of user profile management as it relates to PPP authentication protocols PAP, MSCHAP, CHAP, and SPAP. See 'PPP Authentication Protocols' in *Access Integration Services Software User's Guide* for additional information about configuring PAP, MSCHAP, CHAP, and SPAP.

Authentication can be configured locally or can be configured to consolidate user configuration using authentication servers that are available on the network to service authentication requests for the entire network. The IBM 2212 implements locally maintained authentication as well as the following authentication server protocols:

- Radius
- TACACS
- TACACS+

---

### Using Authentication, Authorization, and Accounting (AAA) Security

Authentication, Authorization, and Accounting (AAA) Security are configurable protocols that allow you to control access to your services. You can configure AAA to perform for local or remote authentication.

You can configure a security protocol for the following types of functions:

- PPP links
- Login users (Telnet/Console Login)
- Tunnels

The configuring is done by setting a primary and secondary server. The server information is configured and stored separately from the AAA configuration. You use a server profile by a name that is provided at configuration time.

Under all circumstances accounting cannot be done locally and must be either Radius or TACACS+.

Authorization can only be done locally, or through remote authentication that uses Radius or TACACS+.

### What is AAA Security?

AAA Security is the name of the security system for this device. It includes:

#### Authentication

The process of identifying a user. Authentication utilizes a name and a password for access.

#### Authorization

The process of determining the services to which a user is allowed access.

#### Accounting

The process of recording when a user has started or stopped a session. There are two types of accounting records supported.

#### Start records

Indicates that a service is about to begin.

## Using Local or Remote Authentication

### Stop records

Indicates that a service has ended.

## Using PPP

For the Point-to-Point Protocol (PPP) you can configure the following:

- Authentication
- Authorization
- Accounting

Each function can have its own security protocol that you configure independently.

- Setting the authentication protocol will have no effect on authorization or accounting.
- Setting the authorization protocol will have no effect on authentication or accounting.
- Setting the accounting protocol will have no effect on authentication or authorization.
- Setting AAA to remote will set authentication to remote, authorization to remote and set accounting to remote.
- Setting AAA to local will set authentication to local and authorization to local. You cannot disable authentication or authorization.

See Point-to-Point Configuration Commands in *Access Integration Services Software User's Guide* for details about the PPP configuration commands that you use in this environment.

## Valid PPP Security Protocols

The following are valid PPP security protocols:

### Authentication Methods

Local, RADIUS, TACACS+, TACACS

### Authorization Methods

Local, RADIUS, TACACS+

### Accounting Methods

RADIUS, TACACS+

Table 26. Set PPP Security Protocols

Action	Authent	Author	Acct
set AAA local	local	local	ignore
set AAA remote	remote	remote	remote
set AUTHENT local	local	ignore	ignore
set AUTHOR local	ignore	local	ignore
set AUTHENT remote	remote	ignore	ignore
set AUTHOR remote	ignore	remote	ignore
set ACCOUNTING remote	ignore	ignore	remote
disable ACCOUNTING	ignore	ignore	disabled

## Using Login

For AAA login configuration, either remote or local can be selected. If local authentication is desired, then Local authorization must also be used. If remote

## Using Local or Remote Authentication

authentication is selected, then, remote authorization must be used. Accounting is not supported locally, so when authenticating and authorizing locally you must disable accounting.

### Attention:

If a remote authentication server does not respond, it is possible to use a local login userid and password when login-of-last-resort is enabled. This allows a single local login attempt if the remote authentication times out. Also, if tech-support-bypass is enabled, the tech support id and password can be used to login and will not transmit the request to the authentication server.

It is important to specify a privilege level when using remote authentication. Login users can enter a correct userid and password, but without a privilege specified the user cannot access the console. Three privilege levels can be set: administrator, operator, and monitor. For RADIUS, either use the SERVICE-TYPE attribute number 6 or add a vendor attribute number 216. See “Appendix. Remote AAA Attributes” on page 617 for details about specific RADIUS attributes.

When configuring remote authentication, you can set authorization to another remote authorization protocol Radius or TACACS+, and set accounting to use Radius or TACACS+.

- Setting AAA to local sets authentication to local, authorization to local, and accounting to disabled.
- Setting AAA to remote sets authentication to remote, authorization to remote, and accounting to remote.
- Setting the authentication protocol to local automatically sets the authorization protocol to the same and disables accounting.
- Setting the authentication protocol to remote automatically sets the authorization protocol to the same only if the authorization protocol is set to local and ignores the accounting protocol.
- Setting the authorization protocol to remote automatically sets the authentication protocol to the same only if the authentication protocol is set to local and ignores the accounting protocol.
- Setting the accounting protocol to remote automatically sets authentication protocol to same only if the authentication protocol is set to local, and sets the authorization protocol to the same only if authorization is set to local.
- Setting the accounting protocol to disable has no effect on the authentication or authorization protocol.
- Disabling authentication or authorization is not allowed.

## Valid Login/Admin Security Protocols

The following are valid Login/Admin security protocols.

### Authentication/Authorization Methods

Local, RADIUS, TACACS Plus

### Accounting Methods

RADIUS, TACACS Plus

## Using Local or Remote Authentication

Table 27. Set Login Security Protocols

Action	Authent	Author	Acct
set AAA local	local	local	disabled
set AAA remote	remote	remote	remote
set AUTHENT local	local	local	disabled
set AUTHOR local	local	local	disabled
set AUTHENT remote	remote	remote, if local else ignore	ignore
set AUTHOR remote	remote, if local else ignore	remote	ignore
set ACCOUNTING remote	remote, if local else ignore	remote, if local else ignore	remote
disable ACCOUNTING	ignore	ignore	disabled

## Using Tunnels

Set tunnel authentication the same as tunnel authorization. When you set tunnel authentication to either local or remote, you can then enable accounting. The tunnel authorization and authentication server must be the same.

The tunnel configuration for accounting also applies to IPSec tunnels. The tunnel authentication and authorization does not apply to IPSec tunnels. You cannot do authentication or authorization for IPSec tunnels using AAA.

## Valid Tunnel Security Protocols

The following are valid Tunnel security protocols:

### Authentication/Authorization Methods

Local, RADIUS

### Accounting Methods

RADIUS, TACACS Plus

Table 28. Set Tunnel Security Protocols

Action	Authent	Author	Acct
set AAA local	local	local	ignore
set AAA remote	remote	remote	remote
set AUTHENT local	local	local	ignore
set Author local	local	local	ignore
set AUTHENT remote	remote	remote	ignore
set AUTHOR remote	remote	remote	ignore
set ACCOUNTING remote	ignore	ignore	remote
disable ACCOUNTING	ignore	ignore	disabled

## Password Rules

Local authentication allows you to use a password to control login access. The password can be checked against any or all of the following rules.

**Note:** The following rules only apply for PPP user login and not console login.

- Be a minimum number of characters in length. You set the number of characters required.

## Using Local or Remote Authentication

- Contain at least one alphabetic character.
- Contain at least one non-alphabetic character.
- Contain a non-numeric character in the first position.
- Contain a non-numeric character in the last position.
- Contain no more than three identical consecutive characters that were used in the previous password.
- Contain no more than two consecutive characters.
- Not contain the userid as a part of the password.
- Not the same as any of the previous three passwords.
- Be changed after a certain number of days. You set the number of days between password changes.
- Locked out after a specific number of login failures. You set the number of failures.

---

## Understanding Authentication Servers

An **authentication server** is a server in the network that validates userids and passwords for the network. If a device is configured for authentication through an authentication server and the device receives a packet from an authentication protocol, the device passes a userid and password to the server for authentication. If the userid and password are correct, the server responds positively. The device can then communicate with the originator of the request. If the server does not find the userid and password that it receives from the device, it responds negatively to the device. The device then rejects the session from which it got the authentication request.

## SecurID Support

The 2212 can authenticate dial-in clients that use SecurID with a Security Dynamics ACE/Server. This support uses TACACS, TACACS+, or RADIUS on the ACE/Server for authentication of the client. Configure the dial-in client the same as other dial-in clients on the 2212.

The dial-in client logs on as usual, but uses the SecurID passcode for the password. The SecurID passcode consists of a 4 to n-digit PIN number that is followed by the number from the SecurID token card. (The maximum number of digits in the PIN depends on the server.) The userid and password could appear as:

Username:	<input type="text" value="John Customer"/>
Password:	<input type="text" value="1234098765"/>

*Figure 25. SecurID Username and Passcode*

When the ACE/Server authenticates the logon, it may request the next token from the client. The next token is the next token on the token card. The maximum number of digits in the next token depends on the SecurID token card the client is using. The client can enter the passcode and the next token when prompted for the password by using the format `passcode*token` as in the following:

## Using Local or Remote Authentication

Username:	John Customer
Password:	1234098765*111111

Figure 26. SecurID Passcode with Next Token

**Note:** When the server requests the client to enter the next token, the client must:

1. Enter the PIN
2. Wait for a new token from the card and enter that token
3. Enter \* followed by the next token from the card

The ACE/Server administrator configures the conditions that cause the server to request the next token or new PIN.

The dial-in clients should use SPAP so they can receive alerts from the authentication system when they need to enter the next token. If the client is not using SPAP and they are not successful logging on, they should try entering a new passcode using the passcode\*token format. If the client is still not successful, there could be other problems between the client and the ACE/Server.

### SecurID Limitations

The following limitations exist:

- Security Dynamics Inc. (SDI) and DES encryption are not supported.
- The SecurID “New PIN” function is not supported.
- TACACS does not support the “New PIN” or “Next-Token” functions. The client can specify a next-token when logging in, but the server will not use it.
- Clients configured for callback are not supported.
- When using CHAP with TACACS or TACACS+, set the CHAP rechallenge interval to 0.
- Do not use CHAP when using RADIUS authentication and SecurID.
- Your clients can obtain the best results by using TACACS+ and SPAP.
- Windows 3.1 DIALs client with SecurID authentication using multilink is not supported.
- When using SecurID authentication, it is highly recommended to use the latest client software (for example, Windows 95 or OS/2).

---

## Chapter 16. Configuring Authentication

This chapter describes the configuration and operational commands for authentication. It includes the following sections:

- “Accessing the Authentication Configuration Prompt”
- “Authentication Configuration Commands”
- “Authentication (AAA) Dynamic Reconfiguration Support” on page 264

---

### Accessing the Authentication Configuration Prompt

To access the AAA Config> prompt:

1. Enter **talk 6** at the \* prompt.
2. Enter **feature auth** at the Config> prompt.

---

### Authentication Configuration Commands

Table 29 lists the commands available at the AAA Config > prompt.

*Table 29. Authentication Configuration Commands*

Command	Function
? (Help)	Displays all the commands available for this command level or lists the options for specific commands (if available). See “Getting Help” on page xxxii.
Disable	Disables various AAA options.
Enable	Enables various AAA options.
List	Displays the AAA configuration parameters.
Login	Configures AAA for login.
Nets-info	Displays information about local PPP authentication.
Password-rules	Configures password rules (enables or disables).
PPP	Configures AAA for PPP.
Servers	Configures individual remote AAA servers.
Set	Configures Authentication parameters regardless of type.
Tunnel	Configures AAA for tunnels.
User-profiles	Configures local PPP users.
Exit	Returns you to the previous command level. See “Exiting a Lower Level Environment” on page xxxii.

### Disable

Use the **disable** command to disable the selected accounting option.

**Syntax:**

```
disable                accounting
                        ipsec-accounting
                        login-last-resort
                        tech-support-bypass
                        unauthent-accounting
```

**accounting**

Specifies that AAA accounting is to be disabled.

**ipsec-accounting**

Specifies that IPSec accounting is to be disabled.

## Configuring Authentication

### **login-last-resort**

Specifies that login last resort is to be disabled.

### **tech-support-bypass**

Specifies that tech support bypass is to be disabled.

### **unauthentic-accounting**

Specifies that unauthentic accounting is to be disabled. PPP sessions that become active without authenticating the user by enabling PPP authentication will not be accounted. Start and stop records will not be transmitted.

## Enable

Use the **enable** command to enable the selected accounting option.

### **Syntax:**

```
enable                accounting  
                        ipsec-accounting  
                        login-last-resort  
                        tech-support-bypass  
                        unauthentic-accounting
```

### **accounting**

Specifies that AAA accounting is to be enabled.

### **ipsec-accounting**

Specifies that IPSec accounting is to be enabled.

### **login-last-resort**

Specifies that login last resort is to be enabled. In the event a timeout occurs while transmitting authentication information to a remote authentication server, a single prompt is displayed to allow a locally authenticated user to login.

### **tech-support-bypass**

Specifies that tech support bypass is to be enabled.

### **unauthentic-accounting**

Specifies that unauthentic accounting is to be enabled.

## List

Use the **list** command to display the AAA parameters.

### **Syntax:**

```
list                   accounting  
                        all  
                        authentication  
                        authorization  
                        config  
                        options
```



## Examples of List Command Output

The following examples show the typical output for the supported list command options:

```
AAA Config> list all
ppp AAA configuration...
  ppp authentication      : Radius      serv01
    authorizeAuthent      YES
    Primary server address 1.1.1.1
    Secondary server address 2.2.2.2
    Request tries         3
    Request interval      3
    Key for encryption    <notSet>
  ppp authorization      : locallist
  ppp accounting         : Disabled
tunnel AAA configuration...
  tunnel authentication   : Radius      serv01
    authorizeAuthent      YES
    Primary server address 1.1.1.1
    Secondary server address 2.2.2.2
    Request tries         3
    Request interval      3
    Key for encryption    <notSet>
  tunnel authorization    : Radius      serv01
    authorizeAuthent      YES
    Primary server address 1.1.1.1
    Secondary server address 2.2.2.2
    Request tries         3
    Request interval      3
    Key for encryption    <notSet>
  tunnel accounting      : Disabled
login AAA configuration...
  login authentication    : Radius      serv01
    authorizeAuthent      YES
    Primary server address 1.1.1.1
    Secondary server address 2.2.2.2
    Request tries         3
    Request interval      3
    Key for encryption    <notSet>
  login authorization     : Radius      serv01
    authorizeAuthent      YES
    Primary server address 1.1.1.1
    Secondary server address 2.2.2.2
    Request tries         3
    Request interval      3
    Key for encryption    <notSet>
  login accounting        : Radius      serv01
    authorizeAuthent      YES
    Primary server address 1.1.1.1
    Secondary server address 2.2.2.2
    Request tries         3
    Request interval      3
    Key for encryption    <notSet>
```

```
AAA Config> list accounting all
accounting AAA configuration...
  accounting ppp          : Disabled
  accounting tunnel       : Disabled
  accounting login        : Radius      serv01
    authorizeAuthent      YES
    Primary server address 1.1.1.1
    Secondary server address 2.2.2.2
    Request tries         3
    Request interval      3
    Key for encryption    <notSet>
```

## Configuring Authentication

```
AAA Config> list accounting config
accounting ppp           : Disabled
accounting login        : Radius      serv01
accounting tunnel       : Disabled
```

```
AAA Config> list authentication all
authentication AAA configuration...
authentication ppp      : Radius      serv01
  authorizeAuthent      YES
  Primary server address 1.1.1.1
  Secondary server address 2.2.2.2
  Request tries         3
  Request interval      3
  Key for encryption    <notSet>
authentication tunnel  : Radius      serv01
  authorizeAuthent      YES
  Primary server address 1.1.1.1
  Secondary server address 2.2.2.2
  Request tries         3
  Request interval      3
  Key for encryption    <notSet>
```

```
AAA Config> list options
Login Last Resort : disabled
Tech Support Bypass: disabled
IPSEC Accounting  : enabled
```

```
INBYTES      enabled
OUTBYTES     enabled
INPKTS       enabled
OUTPKTS      enabled
```

## Login

Use the **login** command to configure AAA for login.

Table 30 lists the subcommands available with the **login** command.

Table 30. Login Subcommands

Command	Function
Disable	Disables accounting for login.
List	Displays the AAA configuration parameters for login.
Set	Sets the AAA configuration parameters for login.

### Disable

Use the **login disable** command to disable accounting.

#### Syntax:

```
login disable           accounting
```

### List

Use the **login list** command to display the AAA configuration parameters.

#### Syntax:

```
login list             all
                        accounting
```

authentication

authorization

config

### Set

Use the **login set** command to configure authentication parameters.

### Syntax:

```
login set          aaa
                   accounting
                   authentication
                   authorization
```

#### **aaa** *authype*

Sets the authentication, authorization, and accounting type. *Authype* is one of the following:

**local** Sets the authentication, authorization, and accounting type to use a locally-maintained user database.

#### **remote**

Sets the authentication, authorization, and accounting type to use a remote user database.

#### **server id**

Specifies the identifier of the remote database.

#### **accounting** *authype*

Sets the accounting type. *Authype* is one of the following:

#### **remote**

Sets the authentication type to use a remote user database.

#### **server id**

Specifies the identifier of the remote database.

#### **authentication** *authype*

Sets the authentication type. *Authype* is one of the following:

**local** Sets the authentication type to use a locally-maintained user database.

#### **remote**

Sets the authentication type to use a remote user database.

#### **server id**

Specifies the identifier of the remote database.

#### **authorization** *authype*

Sets the authorization type. *Authype* is one of the following:

**local** Sets the authorization type to use a locally-maintained user database.

#### **remote**

Sets the authorization type to use a remote user database.

#### **server id**

Specifies the identifier of the remote database.

## Configuring Authentication

### Nets-info

Use the **nets-info** command to display the currently configured PPP authentication protocol on each PPP interface.

**Syntax:**

**nets-info**

### Password-rules

Use the **password-rules** command to configure the password (enable or disable).

Table 31 lists the subcommands available with the **password-rules** command.

*Table 31. Login Subcommands*

Command	Function
Disable	Disables a password rule.
Enable	Enables a password rule.
List	Displays the current state of the password rules (enabled or disabled).

#### Disable

Use the **password-rules disable** command to disable any or all of the password rules.

**Syntax:**

**password-rules disable**      all  
   compare-ident-prev  
   change-days  
   first-non-numeric  
   ident-chars  
   last-non-numeric  
   minimum-length  
   one-alpha  
   one-nonalpha  
   prev-three  
   userid-contained

#### **compare-ident-prev**

Compares the previous user identity with the user requesting a password change.

#### **change-days**

The maximum number of days before a password change is required.

**Valid values:** 0 to 360

**Default value:** 180

#### **first\_non-numeric**

The first character of a password cannot be numeric.

**Valid values:** any non-numeric character

**Default value:** none

### **ident-chars**

Cannot contain more than 3 characters used in a previous password in the same position.

### **last-non-numeric**

The last character in the password cannot be numeric.

**Valid values:** any non-numeric character

**Default value:** none

### **minimum-length**

The least number of characters required to have a valid password.

**Valid values:** 1 to 31

**Default value:** 8

### **maximum-length**

The maximum number of characters a password can contain.

**Valid values:** 1 to 31

**Default value:** 8

### **one-alpha**

At least one character in the password must be an alpha.

### **one-nonalpha**

At least one character in the password must be numeric.

### **prev-three**

The password cannot be the same as any of the last three passwords.

### **userid-contained**

The password cannot contain the userid as a part of the password.

## **Enable**

Use the **password-rules enable** command to enable any or all of the password rules. See the **disable** command for a list of password rule descriptions.

### **Syntax:**

```
password-rules enable    all  
                           compare-ident-prev  
                           change-days  
                           first-non-numeric  
                           ident-chars  
                           last-non-numeric  
                           minimum-length  
                           one-alpha  
                           one-nonalpha  
                           prev-three  
                           userid-contained
```

## **List**

Use the **password-rules list** command to display the current state of the password rules (disabled or enabled).

## Configuring Authentication

### Syntax:

password-rules list

## PPP

Use the **ppp** command to configure AAA for PPP.

Table 32 lists the subcommands available with the **ppp** command.

Table 32. PPP Subcommands

Command	Function
Disable	Disables accounting for PPP.
List	Displays the AAA configuration parameters for PPP.
Set	Sets the AAA configuration parameters for PPP.

### Disable

Use the **ppp disable** command to disable accounting for PPP.

### Syntax:

**ppp disable** accounting

### List

Use the **ppp list** command to display the AAA configuration parameters for PPP.

### Syntax:

**ppp list** all  
accounting  
authentication  
authorization  
config

### Set

Use the **ppp set** command to set the AAA configuration parameters for PPP.

### Syntax:

**ppp set** aaa  
accounting  
authentication  
authorization

### **aaa** *authype*

Sets the authentication, authorization, and accounting type. *Authype* is one of the following:

**local** Sets the authentication, authorization, and accounting type to use a locally-maintained user database.

### **remote**

Sets the authentication, authorization, and accounting type to use a remote user database.

### **server id**

Specifies the identifier of the remote database.

### accounting *authype*

Sets the accounting type. *Authype* is one of the following:

#### remote

Sets the authentication type to use a remote user database.

#### server id

Specifies the identifier of the remote database.

### authentication *authype*

Sets the authentication type. *Authype* is one of the following:

**local** Sets the authentication type to use a locally-maintained user database.

#### remote

Sets the authentication type to use a remote user database.

#### server id

Specifies the identifier of the remote database.

### authorization *authype*

Sets the authorization type. *Authype* is one of the following:

**local** Sets the authorization type to use a locally-maintained user database.

#### remote

Sets the authorization type to use a remote user database.

#### server id

Specifies the identifier of the remote database.

## Servers

Use the **servers** command to configure individual remote AAA servers.

Table 33 lists the subcommands available with the **servers** command.

Table 33. Server Subcommands

Command	Function
Add	Adds a remote AAA server profile.
Change	Changes a remote server profile.
Delete	Deletes a remote server profile.
Lists	Displays the AAA server profile information.

### Add

Use the **servers add** command to add a remote server profile.

#### Syntax:

**servers add** name

**radius** Sets the authentication type to use the radius authentication server protocol.

Values for the following parameters can be set:

#### accounting-level

Specifies the level of accounting information to record. A higher level records all the information listed under levels with lower values.

**Range:** 0 to 10

## Configuring Authentication

**Default Value:** 0

- >0** Record information for:
  - INBYTES\_AH
  - OUTBYTES\_AH
  - INBYTES\_ESP
  - OUTBYTES\_ESP
- >1** Record information for:
  - INPKTS\_AH
  - OUTPKTS\_AH
  - INPKTS\_ESP
  - OUTPKTS\_ESP
- >2** Record information for:
  - INBYTES\_BAD
  - OUTBYTES\_BAD
  - INPKTS\_BAD
  - OUTPKTS\_BAD
- >3** Record information for:
  - INPKTS\_BAD\_AH
  - OUTPKTS\_BAD\_AH
  - INPKTS\_BAD\_ESP
  - OUTPKTS\_BAD\_ESP
- >4** Record information for:
  - INPKTS\_BAD\_AH\_RPLY
  - INPKTS\_BAD\_ESP\_RPLY

### **accounting-port**

Specifies the RADIUS server accounting port.

**Range:** 1 to 10000

**Default Value:** 1646

### **authentication-port**

Specifies the RADIUS server authentication port.

**Range:** 1 to 1000

**Default Value:** 1645

### **author-authent**

Specifies whether authorization attributes are transferred during authentication.

**Valid Values:** yes, no

**Default Value:** yes

### **account-for-packets**

Specifies whether to send packet counts on accounting stop.

**Valid Values:** yes, no

**Default Value:** yes



**key-for-encryption:**

Specifies the encryption key.

**Valid Values:** Any alphanumeric character string up to 32 characters long.

**Default Value:** None.

**primary-server-address:**

Specifies the address of the primary authentication server.

**Valid Values:** Any valid IP address

**Default Value:** 0.0.0.0

**retries**

**Valid Values:** 1 to 100

**Default Value:** 3

**retry-interval**

**Valid Values:** 1 to 60

**Default Value:** 3

**secondary-server-address:**

Specifies the address of the secondary authentication server.

**Valid Values:** Any valid IP address

**Default Value:** 0.0.0.0

**tacacs**

Sets the authentication type to use the TACACS authentication server protocol.

Values for the following parameters can be set:

**primary-server-address:**

Specifies the address of the primary authentication server.

**Valid Values:** Any valid IP address

**Default Value:** 0.0.0.0

**retries**

**Valid Values:** 1 to 100

**Default Value:** 3

**retry-interval**

**Valid Values:** 1 to 60

**Default Value:** 3

**secondary-server-address:**

Specifies the address of the secondary authentication server.

**Valid Values:** Any valid IP address

**Default Value:** 0.0.0.0

**tacacsplus**

Sets the authentication type to use the TACACS+ authentication server protocol.

Values for the following parameters can be set:

## Configuring Authentication

### encryption:

Specifies whether encryption will be used.

**Valid Values:** yes, no

**Default Value:**

### key-for-encryption:

Specifies the encryption key to be used.

**Valid Values:** Any 16-hexadecimal digit value

**Default Value:**

### primary-server-address:

Specifies the address of the primary authentication server.

**Valid Values:** Any valid IP address

**Default Value:** 0.0.0.0

### privilege-level

**Valid Values:** 0 through 15

**Default Value:** 0

### restarts

Sets the number of restarts. This parameter does not include timeout restarts and only pertains to restarts requested by the server.

**Valid Values:** 0 to 3200

**Default Value:** 0

### time-to-connect

The amount of time to allow to obtain the authentication from the server.

**Valid Values:** 1 to 60

**Default Value:** 9

### secondary-server-address:

Specifies the address of the secondary authentication server.

**Valid Values:** Any valid IP address

**Default Value:** 0.0.0.0

## Change

Use the **servers change** command to change a remote server profile. See the **add** command for the remote server profile descriptions.

### Syntax:

```
servers change          radius
                          tacacs
                          tacacsplus
```

See the **servers add** command for remote server profile descriptions.

## Delete

Use the **servers delete** command to delete a remote server profile. See the **add** command for the remote server profile descriptions.

### Syntax:

```
servers delete           radius
                           tacacs
                           tacacsplus
```

See the **servers add** command for the remote server profile descriptions.

### List

Use the **servers list** command to display the AAA server profile information.

### Syntax:

```
servers list           all
                           names
                           profile
```

## Set

Use the **set** command to set the parameters for login, PPP, and L2TP tunnel.

### Syntax:

```
set                   aaa
                           accounting
                           authentication
                           authorization
```

#### **aaa** *authype*

Sets the authentication, authorization, and accounting type. *Authype* is one of the following:

**local** Sets the authentication, authorization, and accounting type to use a locally-maintained user database.

#### **remote**

Sets the authentication, authorization, and accounting type to use a remote user database.

#### **server id**

Specifies the identifier of the remote database.

#### **accounting** *authype*

Sets the accounting type for login, PPP and tunnel. *Authype* is one of the following:

#### **options**

Enables you to enter accounting options.

**bytes** Specifies that accounting is to be done at the byte level.

#### **incoming**

Specifies that accounting is to be done for incoming bytes.

#### **enable**

Enables accounting for the specified options.

## Configuring Authentication

### **disable**

Disables accounting for the specified options.

### **outgoing**

Specifies that accounting is to be done for outgoing bytes.

### **enable**

Enables accounting for the specified options.

### **disable**

Disables accounting for the specified options.

### **packets**

Specifies that accounting is to be done at the packet level.

### **incoming**

Specifies that accounting is to be done for incoming packets.

### **enable**

Enables accounting for the specified options.

### **disable**

Disables accounting for the specified options.

### **outgoing**

Specifies that accounting is to be done for outgoing packets.

### **enable**

Enables accounting for the specified options.

### **disable**

Disables accounting for the specified options.

### **remote**

Sets the authentication type to use a remote user database.

### **server id**

Specifies the identifier of the remote database.

### **authentication** *authtype*

Sets the authentication type for login, PPP, tunnel. *Authtype* is one of the following:

**local** Sets the authentication type to use a locally-maintained user database.

### **remote**

Sets the authentication type to use a remote user database.

### **server id**

Specifies the identifier of the remote database.

### authorization *authype*

Sets the authorization type for login, PPP, and tunnel. *Authype* is one of the following:

**local** Sets the authorization type to use a locally-maintained user database.

**remote** Sets the authorization type to use a remote user database.

**server id** Specifies the identifier of the remote database.

## Tunnel

Use the **tunnel** command to configure AAA for L2TP tunnel.

Table 34 lists the subcommands available with the **tunnel** command.

Table 34. Tunnel Subcommands

Command	Function
Disable	Disables accounting for L2TP tunnel.
List	Displays AAA configuration parameters for L2TP tunnel.
Set	Sets the AAA configuration parameters for L2TP tunnel.

### Disable

Use the **tunnel disable** command to disable accounting for L2TP tunnel.

#### Syntax:

```
tunnel disable           accounting
```

### List

Use the **tunnel list** command to display the AAA for L2TP tunnel.

#### Syntax:

```
tunnel list              all
                           accounting
                           authentication
                           authorization
                           config
```

### Set

Use the **tunnel set** command to set the AAA configuration parameters for L2TP tunnel.

#### Syntax:

```
tunnel set              aaa
                           accounting
                           authentication
                           authorization
```

### aaa *authype*

Sets the authentication, authorization, and accounting type. *Authype* is one of the following:

## Configuring Authentication

**local** Sets the authentication, authorization, and accounting type to use a locally-maintained user database.

**remote**

Sets the authentication, authorization, and accounting type to use a remote user database.

**server id**

Specifies the identifier of the remote database.

**accounting** *authype*

Sets the accounting type. *Authype* is one of the following:

**remote**

Sets the authentication type to use a remote user database.

**server id**

Specifies the identifier of the remote database.

**authentication** *authype*

Sets the authentication type. *Authype* is one of the following:

**local** Sets the authentication type to use a locally-maintained user database.

**remote**

Sets the authentication type to use a remote user database.

**server id**

Specifies the identifier of the remote database.

**authorization** *authype*

Sets the authorization type. *Authype* is one of the following:

**local** Sets the authorization type to use a locally-maintained user database.

**remote**

Sets the authorization type to use a remote user database.

**server id**

Specifies the identifier of the remote database.

## User-profiles

Use the **user-profiles** command to access the User profile config> command prompt. From this prompt, you can access the following commands.

Table 35. User-profile Configuration Commands

Command	Function
? (Help)	Displays all the commands available for this command level or lists the options for specific commands (if available). See "Getting Help" on page xxxii.
Add	Adds a PPP user profile.
Change	Changes a PPP user profile.
Delete	Deletes a PPP user profile.
Disable	Disables a PPP user profile.
Enable	Enables a PPP user profile.
List	Lists the PPP user profile information.
Report	Generates a PPP user profile report.
Reset-user	Resets a PPP user profile.
Exit	Returns you to the previous command level. See "Exiting a Lower Level Environment" on page xxxii.

### Add

Use the **user profiles add** command to add the user profile of a remote user to the local PPP user data base or to give a tunnel peer access through an IP network to the router.

#### Syntax:

```
add                ppp-user
                    tunnel
```

#### ppp-user

Adds the user profile of a remote user to the local PPP user data base. You can add up to 500 users. You add a PPP user for each remote router or DIALS client that can connect to the device you are configuring.

See Add in the chapter “The CONFIG Process (CONFIG - Talk 6) and Commands” in *Access Integration Services Software User’s Guide* for a description of the command syntax and options.

#### Example:

```
Config> add ppp-user
Enter name: [ ]? pppusr01
Password:
Enter again to verify:
Allow inbound access for user? (Yes, No): [yes]
Will user be tunneled? (Yes, No): [No]
Number of days before account expiry[0-1000] [0]? 10
Number of grace logins allowed after an expiry[0-100] [0]? 5
IP address: [0.0.0.0]? 1.1.1.1
Set ECP encryption key for this user? (Yes, No): [No] no
Disable user ? (Yes, No): [No]

      PPP user name: pppusr01
      User IP address: 1.1.1.1
      Virtual Conn: disabled
      Encryption: disabled
      Status: enabled
      Login Attempts: 0
      Login Failures: 0
      Account expires: Sun 17Feb2036 06:28:16
      Account duration: 10 days 00.00.00
      Password Expiry: <unlimited>

User 'pppusr01' has been added
```

#### Example:

```
Config> add ppp-user
Enter name: [ ]? tunusr01
Password:
Enter again to verify:
Allow inbound access for user? (Yes, No): [yes]
Will user be tunneled? (Yes, No): [No] yes
Enter hostname to use when connection to this peer: []? host01
Tunnel-Server endpoint address: [0.0.0.0]? 1.1.1.1

      PPP user name: tunusr01
      Endpoint: 1.1.1.1
      Hostname: host01

User 'tunusr01' has been added
```

**tunnel** Gives a tunnel peer access through an IP network to the router. The peer is then authorized to initiate tunneled PPP sessions into the router.

See Add in the chapter “Configuring the CONFIG Process” in *Access Integration Services Software User’s Guide* for a description of the command syntax and options.

## Configuring Authentication

### Example:

```
Config> add tunnel
Enter name: []? tunnel02
Enter hostname to use when connecting to this peer: []? host02
Set shared secret? (Yes, No): [No]? yes
Shared secret for tunnel authentication:
Enter again to verify:
Tunnel-Server endpoint address: [0.0.0.0]? 2.2.2.22
```

```
Tunnel name: tunnel02
Endpoint: 2.2.2.22
```

### Change

Use the **change** command to change a user-profile.

#### Syntax:

```
change                ppp-user
                        tunnel
```

### Delete

Use the **delete** command to delete a user-profile.

#### Syntax:

```
delete                ppp-user
                        tunnel
```

### Disable

Use the **disable** command to disable a user-profile.

#### Syntax:

```
disable                name
```

### Enable

Use the **enable** command to enable a user-profile.

#### Syntax:

```
enable                name
```

### List

Use the **list** command to list user-profile information.

#### Syntax:

```
list                  ppp-user
                        tunnel
```

```
User profile config> list ppp-user
List (Name, Verb, User, Addr, Encr, zdump): [Verb]
  PPP user name: ppp01
  Expiry: <unlimited>
  User IP address: Interface Default
  Encryption: Not Enabled
  Status: Enabled
  Login Attempts: 0
  Login Failures: 0
  1 record displayed.
```

**List** Specifies how to access the list information.



**Valid values:** name, verb, user, addr, encr, zdump

**Default value:** verb

### PPP user name

Lists the user name.

### Expiry

List the expiration date.

### User IP address

List the users IP address.

### Encryption

Lists whether encryption is enabled or not enabled.

### Status

Lists whether status is enabled or not enabled

### Login attempts

Lists the number of times the user has attempted to login.

### Login failures

Lists the number of failed attempts to login.

## Report

Use the **report** command to generate a PPP user profile report.

### Syntax:

```
report                addresses
                        all
                        callback
                        dump
                        encrypt
                        name
                        password
                        time
                        user
```

```
User profile config> report addresses
PPP user name      User IP address
-----
ppp01              Interface Default
1 record displayed.
```

```
User profile config> report all
  PPP user name: ppp01
    Expiry: <unlimited>
  User IP address: Interface Default
    Encryption: Not Enabled
    Status: Enabled
  Login Attempts: 0
  Login Failures: 0
1 record displayed.
```

## Configuring Authentication

```
User profile config> report callback
PPP user name      Callback type      Phone Number
-----
ppp01
1 record displayed.
```

```
User profile config> report dump
Enter user name: []? user01
```

```
User profile config> report encrypt
PPP user name      Encryption
-----
ppp01              Not Enabled
1 record displayed.
```

```
User profile config> report name
PPP user name
-----
ppp01
1 record displayed.
```

```
User profile config> report password
PPP user name      Expiry      Grace
-----
ppp01              <unlimited>
1 record displayed.
```

```
User profile config> report time
PPP user name      Time allotted
-----
ppp01
1 record displayed.
```

```
User profile config> report user
Enter user name: []? login01
  PPP user name: login01
  Expiry: <unlimited>
  User IP address: Interface Default
  Encryption: Not Enabled
```

### Reset-user

Use the **reset-user** command to reset a user-profile.

#### Syntax:

```
reset-user name
```

---

## Authentication (AAA) Dynamic Reconfiguration Support

This section describes dynamic reconfiguration (DR) as it affects Talk 6 and Talk 5 commands.

### CONFIG (Talk 6) Delete Interface

AAA does not support the CONFIG (Talk 6) **delete interface** command.

### GWCON (Talk 5) Activate Interface

AAA does not support the GWCON (Talk 5) **activate interface** command.

## GWCON (Talk 5) Reset Interface

AAA does not support the GWCON (Talk 5) **reset interface** command.

## CONFIG (Talk 6) Immediate Change Commands

AAA supports the following CONFIG commands that immediately change the operational state of the device. These changes are saved and are preserved if the device is reloaded, restarted, or you execute a dynamically reconfigurable command.

Commands
CONFIG, add ppp-user
CONFIG, feature authentication, enable login-last-resort
CONFIG, feature authentication, disable login-last-resort <b>Note:</b> Effective for the next login sequence.
CONFIG, feature authentication, enable tech-support-bypass
CONFIG, feature authentication, disable tech-support-bypass <b>Note:</b> Effective for the next login sequence.
CONFIG, feature authentication, enable unauthentic-accounting
CONFIG, feature authentication, disable unauthentic-accounting

## Non-Dynamically Reconfigurable Commands

The following table describes the AAA configuration commands that cannot be dynamically changed. To activate these commands, you need to reload or restart the device.

Commands
CONFIG, feature authentication, server add
CONFIG, feature authentication, server change
CONFIG, feature authentication, server delete
CONFIG, feature authentication, enable ipsec-accounting
CONFIG, feature authentication, disable ipsec-accounting
CONFIG, feature authentication, ppp set
CONFIG, feature authentication, tunnel set
CONFIG, feature authentication, login set
CONFIG, feature authentication, set accounting options
CONFIG, feature authentication, password-rules enable
CONFIG, feature authentication, password-rules disable

## Configuring Authentication

---

## Chapter 17. Using and Configuring Encryption Protocols

The objective of encryption is to transform data into an unreadable form to ensure privacy. The **encrypted** data needs to be decrypted to get the original data.

The 2212 supports:

- The RC4 encryption algorithm with 40- and 128-bit keys for Microsoft Point-to-Point Encryption (MPPE) on PPP interfaces.
- The Data Encryption Standard in Cipher Block Chaining Mode (DES-CBC) algorithm with 56-bit keys for PPP Encryption Control Protocol support as described in RFCs 1968 and 1969.
- The commercial Data Masking Facility (DMF) which uses 40-bit keys for Frame Relay Encryption. This support is proprietary.
- Frame Relay also uses triple-DES and a 128-bit key.

---

### PPP Encryption Using Encryption Control Protocol

The Encryption Control Protocol (ECP) is used in the router to negotiate the use of encryption on the point-to-point links communicating using PPP protocol. The Encryption Control Protocol provides a generalized mechanism to negotiate which encryption and decryption algorithms will be used over a PPP link. Different encryption algorithms can be negotiated in each direction of the PPP link.

A method of encryption and decryption is called an **encryption algorithm**. Encryption algorithms use a key to control encryption and decryption. Unlike compression, the router encrypts in both directions of the link, because encrypting in only one direction is a security risk. The link will be terminated whenever ECP cannot negotiate encryption algorithms in both directions.

### Configuring ECP Encryption for PPP

To configure the device to use encryption at the data link layer:

1. Set the encryption keys for remote devices and local PPP interfaces.  
Set the encryption key for the remote device using the **add ppp-user** command at the `Config>` prompt. See the **Add** command in the chapter “Configuring the CONFIG Process” in *Access Integration Services Software User’s Guide* for a description of the command syntax and options.  
Set the encryption key for the local PPP interface using the **enable ecp** command (see the talk 6 PPP `Config> enable` command in the *Access Integration Services Software User’s Guide*).
2. Configure individual PPP links to use Encryption Control Protocol (ECP) by using the **enable ecp** command at the PPP `Config>` prompt.
3. Enable PAP, CHAP, or SPAP.

You can also disable encryption, change the encryption key for a user, list the status of encryption, or set the name that the device uses when requesting encryption. For information about:

- Disabling encryption, see the PPP `Config> disable ecp` command in the *Access Integration Services Software User’s Guide*.
- Changing the remote user’s encryption key and password, see the `Config> change ppp-user` command in the *Access Integration Services Software User’s Guide*.

- Listing the encryption status, see the PPP Config> **list ecp** command in the *Access Integration Services Software User's Guide*.
- Setting the device's name, see the PPP Config> **set name** command in *Access Integration Services Software User's Guide*.

## Monitoring ECP Encryption for PPP

You can monitor the various encryption settings on the interfaces by:

1. Accessing the monitoring prompt using the **talk 5** command.
2. Selecting the interface you want to monitor using the **network** command. This command puts you at the PPP n> prompt, in which *n* represents the network number. Refer to "Configuring and Monitoring Point-to-Point Protocol Interfaces" in the *Access Integration Services Software User's Guide* for instructions about using the **network** command.

From this prompt, you can:

- List the current state of encryption, the most recent encryption negotiation, the elapsed time since an encryption state change, and the algorithms in use by the encrypters. (Refer to the **list control ecp** command in the *Access Integration Services Software User's Guide*.)
- List the encryption control packets received and transmitted on the interface. (See the **list ecp** command in the *Access Integration Services Software User's Guide*.)
- List the encrypted data packets transmitted or received on the interface. (see the **list edp** command in the *Access Integration Services Software User's Guide*.)

---

## Microsoft Point-to-Point Encryption (MPPE)

Microsoft Point-to-Point Encryption (MPPE) provides a way for remotely-attached Windows workstations known as Microsoft Dial-Up Networking (DUN) clients to encrypt data that is transmitted over a PPP link between themselves and the 2212. MPPE can also be used to encrypt data being transmitted over a PPP link from router to router. MPPE is always negotiated in both directions.

MPPE uses secret key algorithms to perform encryption. In secret key algorithms, the same key is used for encryption and decryption. This key is not configured by the user, but is generated in the process of the negotiation of MPPE between the sending and the receiving workstations. To use MPPE, you must configure the authentication protocol Microsoft Challenge/Handshake Authentication Protocol (MS-CHAP).

If the PPP interface is authenticated with MS-CHAP, the router goes into a "Microsoft mode", in which it will negotiate only MPPC if compression is enabled and negotiate only MPPE if encryption is enabled. In "Microsoft mode", the router ignores the priority list of compression algorithms and disables ECP negotiation.

## Configuring MPPE

To configure MPPE, you should perform these steps for each interface:

1. Configure MS-CHAP. In the *Access Integration Services Software User's Guide*, see "Microsoft PPP CHAP Authentication (MS-CHAP)" and "Configuring and Monitoring Point-to-Point Protocol Interfaces" for information about using and configuring MS-CHAP.
2. If you are configuring a router-to-router connection, set the name for the local PPP interface using the **set name** command (see the PPP Config> **set name** command in the *Access Integration Services Software User's Guide*).

3. If you want data compression, enable MPPC using the talk 6 **enable ccp** command at the PPP Config> prompt. MPPE does not require data compression.
4. Enable MPPE. Use the **enable mppe** command at the PPP Config> prompt (see the PPP Config> **enable** command in the *Access Integration Services Software User's Guide*).
5. Restart the router to activate the configuration.

You can also disable MPPE and list the MPPE options.

- Use the talk 6 **disable mppe** command at the PPP Config> prompt to disable MPPE.
- Use the talk 6 **list ccp** command at the PPP Config> prompt to list the MPPE options that have been configured.

## Monitoring MPPE

Bring up the PPP> prompt as described in “Monitoring ECP Encryption for PPP” on page 268. Use the **list mppe** command to see the MPPE data statistics and the **list control ccp** command to see the MPPE status. Examples of the outputs of these commands are displayed in “Configuring and Monitoring Point-to-Point Protocol Interfaces” in the *Access Integration Services Software User's Guide*.

---

## Configuring Encryption on Frame Relay Interfaces

**Note:** Frame relay uses a proprietary encryption scheme.

Data encryption is supported on all interfaces on which you have enabled encryption. You can configure individual circuits on an encryption-enabled interface to perform or not perform encryption as desired.

To configure the device to use encryption on frame relay links:

1. Access the frame relay configuration prompt using the **talk 6** command.
2. Select the frame relay interface that you want to be encryption-capable using the **net #** command
3. Enable encryption on the frame relay interface using the **enable encryption** command. See the Frame Relay configuration commands in the *Access Integration Services Software User's Guide*.
4. Add encryption—capable permanent virtual circuits and define the encryption key for each of the PVCs using the **add permanent-virtual-circuit** command. See the Frame Relay configuration commands in the *Access Integration Services Software User's Guide*.
5. Repeat steps 1 through 4 for each encryption-capable interface you are configuring.

**Note:** If encryption is enabled for a FR permanent virtual circuit then data will not flow over the circuit unless encryption is successfully negotiated with the device at the other end of the virtual circuit. Encryption is not supported for orphan circuits since you must configure the PVC in order to enter the encryption key.

You can also disable encryption for an interface, change the encryption settings for a PVC or list the status of encryption. For information about

- Disabling encryption on an interface, see the Frame Relay Configuration **disable encryption** command in the *Access Integration Services Software User's Guide*.

- Changing the encryption settings for a PVC, see the Frame Relay Configuration **change permanent-virtual-circuit** command in the *Access Integration Services Software User's Guide*.
- Listing the encryption status, see the Frame Relay Configuration **list all**, **list lmi**, and **list permanent-virtual-circuit** commands in the *Access Integration Services Software User's Guide*.

---

## Monitoring Encryption on Frame Relay Interfaces

You can monitor the various encryption settings on the interfaces by:

1. Accessing the monitoring prompt using the **talk 5** command.
2. Selecting the interface you want to monitor using the **network #** command. This command puts you at the FR x> prompt.

From this prompt, you can list the current encryption state for an interface, a PVC, or a circuit. See the Frame Relay Monitoring **list** command in the *Access Integration Services Software User's Guide*.



---

## Chapter 18. Using the Policy Feature

This chapter describes how the policy feature interacts with other router software components to make decisions about QoS, security, or both. It also describes the concepts and specific configuration commands related to the policy feature. The policy feature also allows an LDAP directory server to be used as a central repository for policy information. The concepts and configuration steps needed to enable the LDAP functions are also described in this chapter. The following topics discuss these concepts, the way in which routers enforce policies, and also provide examples.

- “Overview of Policy”
- “LDAP and Policy Database Interaction” on page 278
- “Generating Rules” on page 282
- “Configuration Examples” on page 283

---

### Overview of Policy

The policy feature facilitates the management of IPv4 traffic in a network. You may configure policies for very simple filter rules (drop or pass) or for complex security and QoS scenarios. The combination of policies determines how routers handle IPv4 traffic in a network.

### Policy Decision and Enforcement

The policy implementation in this family of routers constitutes the basis for policy decisions and the means of enforcing them. These concepts are often referred to as a policy decision point (PDP) and a policy enforcement point (PEP).

The policy database, which resides in the router’s memory, is comprised of the set of policies loaded from local configuration and policies that have been read from LDAP. The policy database is built under the following conditions:

- Device reload or restart
- **reset database** monitoring command
- Automatic refresh
- SNMP set request

The policy database serves as the PDP, and consists of a set of policies that determine how the policy feature-related components handle packets. When a policy results in a decision (based on information such as the time of day, IP packet information, and protocol-specific information such as identification), the decision is passed to the enforcement component (PEP) to carry out the action. Figure 27 on page 272 shows the relationship of these components.

## Using the Policy Feature

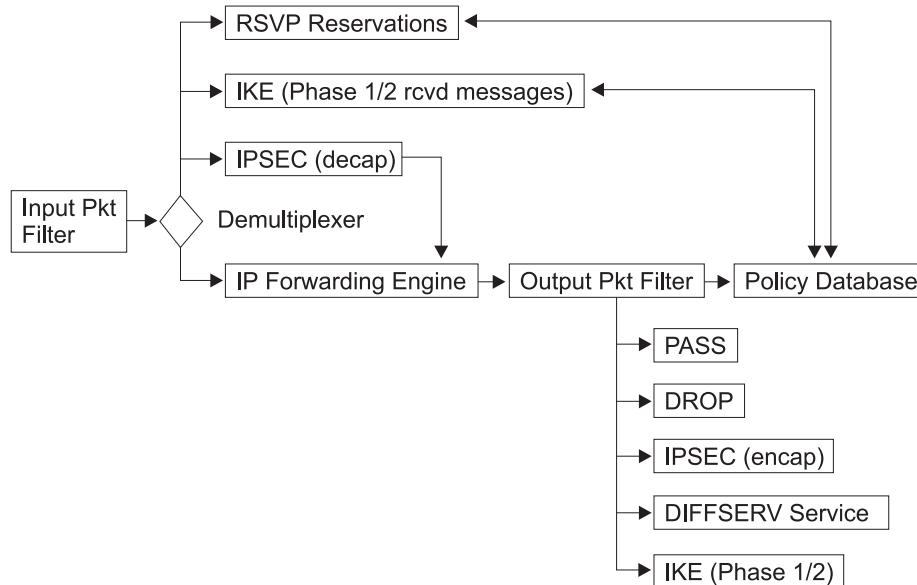

Figure 27. IP Packet Flow and the Policy Database

### Policy Decision and Packet Flow

IP Packets first must pass the input packet filter before any other actions can be taken. If the input packet filter has rules present then the packet may have some action taken on it. If there is a filter match that excludes the packet or there is no match found in the input packet filter then the packet is dropped.

If the packet passes the input packet filter then it goes to a demultiplexing filter, which checks to see whether the packet is locally destined. If it is, then depending on the type of packet it is passed to other modules. These modules may be IPsec, IKE, RSVP, or others. If the packet is locally destined for IPsec, IKE, or RSVP then those modules may query the policy database to determine which action to take.

If the packet is not locally destined then it is given to the forwarding engine and a routing decision is made. If the routing decision does not drop the packet (Policy Based Routing may decide to drop the packet), then the packet goes to the output packet filter. If filter rules are present in the output packet filter then the packet may have address translation performed (NAT), may be passed or may be dropped. If no filter rules are present then the packet is passed. If filter rules are present and no match is found then the packet is dropped. If the packet passes the Output Packet filter then the IP Engine queries the policy database to determine whether any other actions should be performed on this packet.

**Note:** If the input and output packet filters are enabled for an interface(s), and packets that are to be controlled by the policy database are expected to traverse these interfaces, then a filter rule that includes these packets must be present in the input and output packet filters so they will not be dropped before the policy database is queried. One suggestion is to use the policy database to configure all the pass/drop rules and not to use the packet filters.

### IP Policy Queries

When the IP forwarding engine queries the policy database, the following types of decision combinations may be returned:

- No match found—pass the packet

- Match found—drop the packet
- Match found—pass the packet
- Match found—secure the packet in IPSec manual tunnel x
- Match found—secure the packet in IKE negotiated IPSec tunnel x
- Match found—start ISAKMP negotiations for Phase 1 and 2, drop packet
- Match found—provide DiffServ QoS x, secure packet with IPSec

### IPSec Policy Queries

If IPSec receives a packet then it must first decapsulate the packet and then decide whether the packet arrived in the correct IPSec tunnel (often referred to as the conformance check). It does this by querying the policy database. The policy database may return the following types of decisions for this query:

- Conformance check passed—forward the packet
- Conformance check failed—drop the packet

### IKE Policy Decisions

IKE may query the policy database and have the *Phase 1* IP policy decisions shown in Table 36 returned.

Table 36. IKE Phase 1 Queries and the Decisions Returned

Query Type	Decision
Message 1 (Main Mode)	No match found, drop packet
Message 1 (Main Mode)	Match found, negotiate with Phase 1 policy x
Message 5 (Main Mode)	No match found, stop negotiations with peer, drop packet
Message 5 (Main Mode)	No match found, stop negotiations with peer, drop packet
Message 5 (Main Mode)	Match found, policy x matched, finish Phase 1
Message 5 (Main Mode)	Match found, policy y matched, stop current Phase 1 and initiate new Phase 1 with new policy
Message 1 (Aggressive Mode)	No match found, drop packet
Message 1 (Aggressive Mode)	Match found, policy x matched

IKE may query the policy database and have the *Phase 2* IP policy decisions shown in Table 37 returned.

Table 37. IKE Phase 2 Queries and the Decisions Returned

Query Type	Decision
Message 2 (responder)	No match found, drop packet
Message 2 (responder)	Match found, negotiate with policy x

### RSVP Policy Decisions

If a packet is an RSVP control message then RSVP queries the policy database to determine whether to accept or deny the reservation. If it is accepted then RSVP determines which attributes of the reservation to limit, based on the policy. Policies in the policy database can control the duration of the reservation, the amount of bandwidth that should be allocated, and the minimum delay to guarantee.

## Policy Objects

A policy is made up of a profile, which contains a set of packet attributes upon which to base decisions, actions to take if a packet's attributes match those in the profile, and a validity period during which the decisions are made and the actions are enforced. These items are explained in greater detail in the following topics:

The parts that make up a policy are distinct named objects. Policy objects may refer to one another, and as a group of related items they comprise a policy. By

## Using the Policy Feature

separating configuration information into separate distinct objects, you can reuse many of them across multiple policy definitions, thus saving time and reducing maintenance efforts. Individual policy objects are discussed in detail in the following topics.

### Policy

The policy object describes which conditionals should be checked against, and if the checks match, which actions to enforce. The policy makes named references to the validity period and the profile. For the policy to be valid, these references are required. The policy must also make a named reference to one or more of the following actions: an IPSec manual-keyed tunnel object, an IPSec action, an ISAKMP action, an RSVP action, or a DiffServ action. Valid combinations are:

- IPSec manual-keyed tunnel
- IPSec action to drop packets
- IPSec action to pass packets (no security)
- IPSec action to secure packets, ISAKMP action
- DiffServ action (drop)
- IPSec manual-keyed tunnel and DiffServ action (pass)
- IPSec action to secure packets, ISAKMP action, DiffServ action (pass)
- RSVP action
- RSVP action and DiffServ action (pass)

**Note:** In these combinations an IPSec manual tunnel cannot exist in the same policy definition as an IPSec action (IKE-negotiated IPSec tunnel), and an RSVP action must not be associated with any kind of IPSec action. If an IPSec action to secure packets is associated with a policy then you must also associate an ISAKMP action with the policy.

Each policy also has a priority number associated with it (the higher the number in the priority attribute, the higher the priority). The priority determines whether this policy takes precedence over another policy. Typically, you only have to set this if two or more policies' profiles conflict with each other in some way. The policy with the more specific profile should have a higher priority. For example, suppose that one policy specifies that traffic from subnet A to subnet B is to be secured with IPSec (DES) and another policy specifies that traffic from point a' (a particular host inside of subnet A) to subnet B is to be secured with IPSec (3DES). The more specific policy (a' to B) should have a higher priority than the policy with A to B.

It is a good idea to designate initial priority values that are 5 or more digits apart to allow room for specifying additional priority values for conflicting policies later. Each policy also has an enabled attribute, which determines whether the policy is to be enabled when loaded into the policy database. If a policy match is found during a policy database search but the policy is disabled, then the next most specific policy is enforced.

You can initiate a check for consistency and conflicts both within a single policy and between all defined policies by using the **check-consistency** monitoring command. This command does not attempt to resolve any problems, but identifies them so you can take corrective action. See "Policy Monitoring Commands" on page 332 for details on the command.

## Profile

The profile determines which information is to be used to select a particular policy. The profile consists of source address and destination address information, protocol information, and source and destination port information.

**Note:** When defining policies for IPSec/ISAKMP, each gateway providing the security must have a policy to define the security association. The profile on each gateway must associate the source with the destination and the destination with the source. The profile for an IPSec policy must specify the source address as the traffic to be encapsulated into the tunnel and the destination address must be at the remote end of the tunnel.

The profile can also select based on the type-of-service (TOS) byte and the ingress and egress IP address. By default a packet received on any input interface and which leaves on any output interface is matched against the other selectors. In some cases, you may need the flexibility to specify exactly the interfaces on which the packet must arrive, and the interface on which the packet must leave. If you want this, then you must add interface-pair objects and associate the group name for the interface pair objects with the profile. You assign interface-pair objects to a group by giving them the same name. This allows you to specify combinations such as (any packet arriving on IPAddrX and leaving on any interface *OR* any packet coming in any interface and leaving on IPAddrX). This is particularly useful if you define a general drop rule for a public interface.

**Interface Pair:** Identifies the input interface and output interface. Specify the IP addresses for the interface for this selection. A value of 255.255.255.255 implies any interface.

If you want to use the profile to select an IPSec/ISAKMP policy, then you have the option of specifying the local ID to be sent during Phase 1, and the list of acceptable remote IDs during Phase 1 negotiations. By default, the local ID is the local tunnel endpoint for the IPSec/IKE traffic, and the remote ID list is *Any*. Optionally, you may specify the fully qualified domain name (FQDN), user FQDN, and key ID. Normally this is sufficient because all ISAKMP Phase 1 negotiations are authenticated with either public certificates or pre-shared keys. However, in some remote access situations in which the policy is wild-carded out for the destination addresses, it may be wise to specify a list of remote access users that are to be allowed access to network resources.

These users are still authenticated through the normal ISAKMP authentication methods, but the policy database performs an additional authentication step by ensuring that the local ID sent by the remote peer matches one of the IDs specified in the Remote User Group of the policy's profile. This is required if a public certificate authority (CA) is administering certificates to the general public, and the network administrator only wants a specific set of these users (for example, company employees) to have access. The remote user group is comprised of a list of users who belong to the same group. These users are entered by adding one or more *USERS*. A group of users can be making the group name for each user the same. This group can then optionally be associated with a profile.

## Validity Period

The validity period specifies the life of the policy—the year, the months of the year, the days of the week, and the hours of the day that it is valid. This flexibility enables the network administrator to specify when a policy is valid, for example “all the time” or “only this year, during the months of January, February and March, on Monday through Friday, from 9 AM to 5 PM.” When a policy in the policy database becomes

## Using the Policy Feature

invalid, the next most specific policy will be enforced. Thus you could define a policy that specifies on Monday through Friday from 9 am to 5 am to secure all traffic from subnet A to subnet B, and at any other time drop all traffic from subnet A to subnet B. In this case the first policy must have a higher priority (specified when you enter the **add policy** monitoring command).

### DiffServ Action

The DiffServ action describes the quality of service that is to be provided to packets that match a policy that specifies a DiffServ action. You may configure the DiffServ action to drop packets. You may also use the DiffServ action to map packets into relative qualities of service. You may configure the bandwidth allocated as a percentage of output bandwidth or as an absolute value in kbps. You must specify whether the assured (AF)/best effort queue or the premium (EF) queue is to provide the bandwidth allocation. For more information on these queues and how to define them, see “Chapter 22. Using the Differentiated Services Feature” on page 391 and “Chapter 23. Configuring and Monitoring the Differentiated Services Feature” on page 399.

The DiffServ action also specifies how to mark the DS codepoint (TOS byte) for EF and AF traffic before it is sent on the egress interface. The EF and AF traffic is metered, and non-conforming traffic is policed. Non-conforming EF traffic is dropped and, optionally, non-conforming AF traffic's DS byte is re-marked using the Three Color Marker (TCM) scheme. The packet marking, metering, and policing enables the core router in a DiffServ-enabled network to classify the packet based on DS codepoints and control congestion by dropping non-conforming traffic first. This helps to achieve increased throughput and lower delay for preferred traffic in DiffServ-enabled networks.

### RSVP Action

The RSVP action specifies whether to permit or deny RSVP flows if an RSVP reservation occurs and the reservation request matches the profile of the policy. If you want to permit the reservation, then the RSVP action also states the allowed duration of the reservation, the allowed bandwidth, and optionally, a reference to a DiffServ action. The reference to the DiffServ action enables RSVP to determine how to mark the TOS byte before the packet leaves the router. This is useful when packets pass from an RSVP network into a DiffServ network. RSVP can provide the QoS up to the RSVP boundary and then mark the TOS byte appropriately so the DiffServ network can apply the correct bandwidth.

### IPSec Action

The IPSec action may specify either a drop, pass, or secure action. If the action is drop, then all packets matching this policy are dropped. If the action is pass with no security, then all packets are passed in the clear. If the action is pass with security, then all packets are secured by means of the security association (SA) specified by this action. The IPSec action also contains the IP addresses of the tunnel endpoints for the IPSec tunnel and IKE SAs.

The attributes of the SA are determined by the IPSec proposals that the IPSec action references. The IPSec action may specify multiple IPSec proposals and they are sent and checked against in the order they are specified. Having multiple proposals in an IPSec action allows the configuration to contain all the acceptable combinations of security, thereby reducing the number of potential configuration mismatches between VPN gateways.

### IPSec Proposal

The IPSec proposal contains the information about which ESP, AH, (or both) transform to propose or check against during Phase 2 ISAKMP negotiations. If you

require perfect forward secrecy (a fresh Diffie Hellman calculation), then the IPSec proposal identifies which DH group to use. The transforms that the IPSec proposal references are sent or checked against in the order in which they are specified. The first ESP or AH transform in the list must be the one that is most appropriate to use. If more than one transform is in the list, then each one is compared to the peer's list of transforms to find a match. If none of the configured transforms match the peer's list then the negotiation fails. The IPSec proposal may list a combination of AH and ESP transforms, but the only valid combinations are:

- List of AH only (tunnel or transport mode)
- List of ESP only (tunnel or transport mode)
- List of AH (transport mode) and list of ESP (tunnel mode)

### IPSec Transform

The attributes of the IPSec transform contain information about the IPSec encryption and authentication parameters and also specify how often the keys are refreshed. The transform is either AH (authentication only) or ESP (encryption, authentication, or both) and may be configured to operate in either tunnel or transport mode.

### ISAKMP Action

The ISAKMP action specifies the key management information for Phase 1. It specifies whether the Phase 1 negotiations are to start in main mode (provides identity protection) or in aggressive mode. It also specifies whether the Phase 1 security association is to be negotiated at device start-up or on demand. The ISAKMP action also must reference one or more ISAKMP proposals. The first reference must be to the most acceptable ISAKMP proposal.

### ISAKMP Proposal

The ISAKMP proposal specifies the encryption and authentication attributes of the Phase 1 security association. It also specifies which Diffie Hellman group to use to generate the keys, and the life of the Phase 1 security association. You must select the authentication method in the ISAKMP proposal. It can be either pre-shared key or certificate mode.

### User

You must configure a USER for any policy that uses an ISAKMP negotiation with pre-shared key as the authentication method. The USER configuration identifies the pre-shared key to use for the ISAKMP peer. The user object contains the identifying information for a remote ISAKMP peer, that is IP address, FQDN, user FQDN or key ID, and which method the user wants to use for authentication. You may select either pre-shared key or certificate mode. If you select pre-shared key, then you must also specify whether the pre-shared key must be entered in ASCII or hexadecimal, and the value of the key. USERS may be grouped together by assigning them to the same group name. This group can then optionally be associated with a policy's profile to perform a more strict policy lookup for Phase 1.

### IPSec Manual-Keyed Tunnel

The IPSec manual-keyed tunnel is a static configuration of the encryption and authentication parameters. No negotiation is performed for the tunnel so both peers must have exactly the same configuration. The keys are actually entered as part of this configuration and must match on both sides of the tunnel. Since no negotiation is performed in this mode, the keys are never refreshed. For more information about IPSec manual-keyed tunnels, see the discussion of the IPSec feature in "Chapter 20. Using IP Security" on page 341.

## Using the Policy Feature

Figure 28 shows the relationship between policy configuration objects.

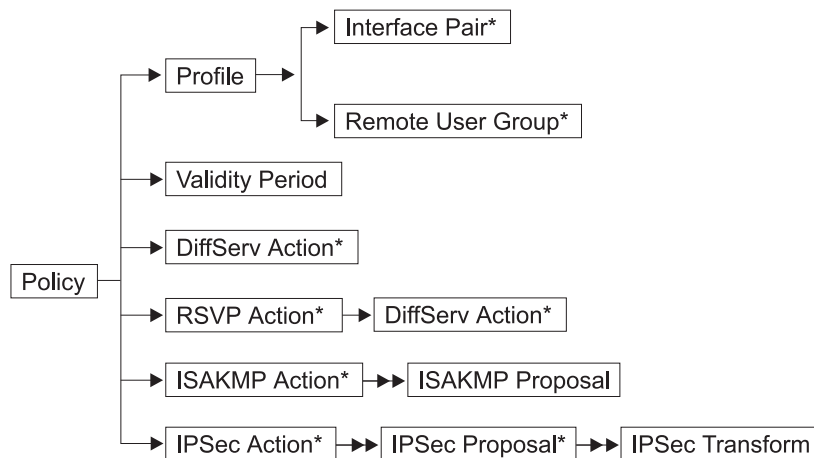

Notes:

1. The → indicates a single reference.
2. The →→ indicates a multiple reference.
3. The \* indicates an optional reference.
4. In a security policy for ISAKMP/IPSec, the traffic profile defines the traffic flowing into the secure tunnel.

Figure 28. Relationship of Policy Configuration Objects

---

## LDAP and Policy Database Interaction

This family of routers allows a Lightweight Directory Access Protocol (LDAP) server to be the repository of policy information (the policy database). LDAP is a protocol that allows a directory server to be searched and modified. LDAP is a lightweight version of the X.500 standard. The routers support the ability to search for (but not modify) information in the directory server. The policy search agent in the router retrieves all the policy information in the directory server that is intended for that device. Any LDAP server operating at LDAP Version 2 or 3 works with the implementation in the router. An important advantage of using a directory server to store policy information as opposed to more traditional methods of locally stored configuration is the ability to make a change in one place and have that change applied across all the devices in the extended network. This includes devices in the administrative domain as well as devices across public boundaries.

For example, suppose you have an IPSec transform definition that resides in the directory. If you want to change the corporate policy for encryption from DES to 3DES, this would normally require a change in every device configuration across each network boundary. If you use the directory to deploy the policies then you only have to change one IPSec transform. Each policy-enabled device in your network would then need to rebuild the database. As another example, suppose you need to change a DiffServ action named “GoldService” to increase the bandwidth value from 40% to 45% of bandwidth. The LDAP server and policy infrastructure allow these types of configuration changes to scale much better and they reduce configuration mismatches.

If you are the network administrator, you may also take advantage of the ability to refresh the database automatically at a specified time each day. Select this option by entering the policy feature’s **set refresh** command. You may specify whether



## Using the Policy Feature

refreshing is enabled or not and, if enabled, the time at which the database is to refresh. This option is useful for making automated changes. For example, suppose that you must add a new policy so that the marketing department in the U.S. can talk to the development department in Japan across the Internet, and that the security gateways are SG1 and SG2. You can simply enter this information into the directory, and at midnight SG1 and SG2 automatically pick up this change if they are enabled for automatic refresh.

Upon successfully reading policy information from the LDAP server, you may want to cache this information into persistent storage on the device. Once you have done this, you can choose to always read the cached information, thereby eliminating the time needed to interrogate the LDAP server. You may also choose to have the policy search engine read the cached copy if the LDAP server is not available when a refresh is requested. See the **cache-ldap-plcys** and **flush-cache** monitoring commands at “Policy Monitoring Commands” on page 332 and the **enable ldap** configuration command at “LDAP Policy Server Configuration Commands” on page 327 for details.

The LDAP policy search engine enables you to specify the security level to be used while building the policy database. You define these security options with the policy feature's **set default** command. The options are:

- Pass all traffic during the search (default).
- Drop all traffic *except* LDAP policy search requests and results.
- Drop all traffic *except* LDAP policy search requests and results protected by IPsec.

In some situations either of the first two options are sufficient. However, if the LDAP traffic will traverse the public infrastructure, you should secure and authenticate the information by selecting the third option. If you do this, you must select Phase 1 and Phase 2 authentication and encryption options. You must also enter the IP addresses for the tunnel endpoints (primary and secondary LDAP servers). This

## Using the Policy Feature

boot-strap IKE/IPSec tunnel will be negotiated before any LDAP traffic is sent. This feature allows you to establish the configuration shown in Figure 29. This figure shows an LDAP server on Subnet A in the corporate network. SG1,

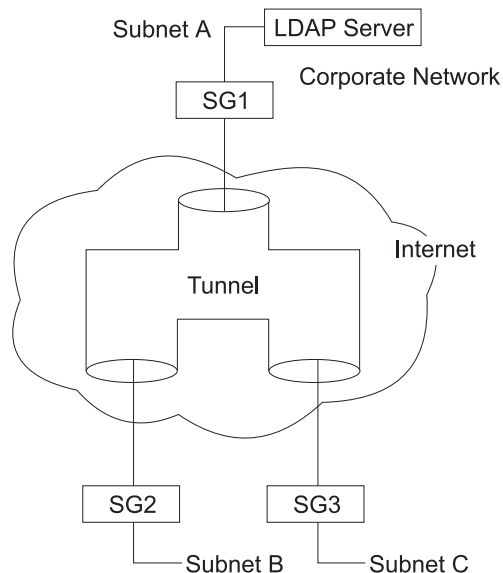

Figure 29. Securing Traffic Across the Internet

SG2, and SG3 are fetching their policies from the LDAP server. The policy search for SG2 and SG3 occurs across the Internet and is protected through IPSec.

The configuration information required for the policy database to successfully retrieve the policies from the directory is:

- Primary server IP address (a backup secondary server may also be configured)
- Port number on which the server is listening (Note: SSL and TLS are not supported)
- Username and password information if required
- Base distinguished name of the DeviceProfile object for this router or class of routers.
- Default policy information

After you have entered this configuration information, the next time the policy database is refreshed an attempt is made to interrogate the directory server for policy information. The policy database allows for a combination of locally configured policies and rules read from the LDAP server. If two rules are found to be conflicting and they are at the same priority, then the rule read from the local configuration take precedence over the rule read from the directory server.

## Policy Schema

The LDAP schema is the set of rules and information making up the class and attribute definitions that determine the contents of entries in the directory. Typically the LDAP schema is written in ASN1 syntax, similar to SNMP MIBs. The policy schema that this family of routers supports is a work that comprises pre-standard efforts being done in the IETF. It is based on the standards track work being done by the IPSec and Policy Working Groups in the IETF and the Policy Working Group in the DMTF. The policy schema closely matches the existing configuration objects in the policy feature on the router. The policy schema definition files and LDAP server configuration files may be found by accessing the following URL:

**<http://www.networking.ibm.com/support>**. Please select the router product you

want and then select the *Downloads* link. Figure 30 shows the overall structure of the policy schema.

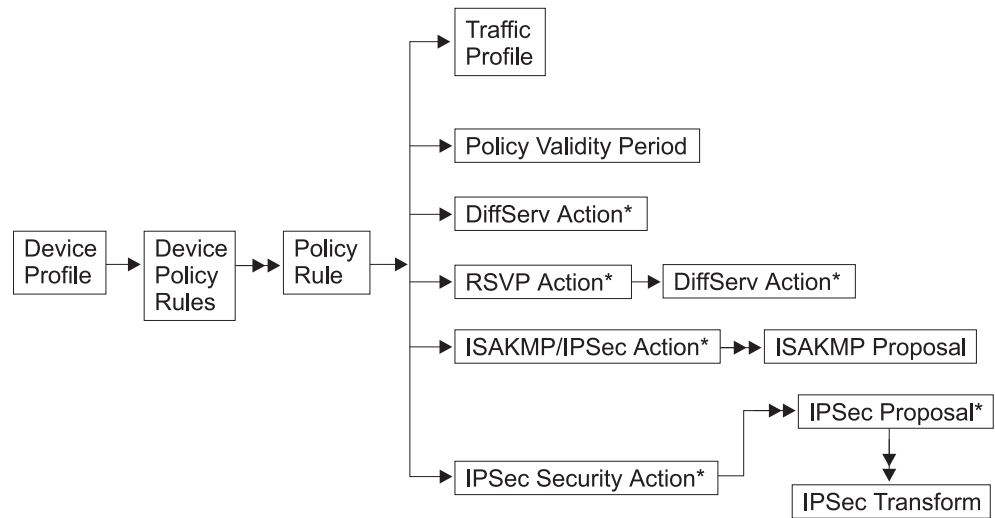

Notes:

1. The → indicates a single reference.
2. The →► indicates a multiple reference.
3. The \* indicates an optional reference.
4. In a security policy for ISAKMP/IPSec, the traffic profile defines the traffic flowing into the secure tunnel.

Figure 30. Policy Schema Structure

The DeviceProfile and DevicePolicyRules are two key objects in the policy schema. They enable the policy search agent to locate the policies needed for the device. The DeviceProfile contains information about the device's administrative IP address and a mandatory DevicePolicyRules reference. You may group devices together into one DeviceProfile or each device in the network can have its own DeviceProfile. The choice you make depends on whether more than one device in the network must fetch the same set of rules. Typically, for security gateways this is not the case because every gateway has a different tunnel endpoint. For QoS-only devices, it is conceivable that all devices in a group would all read the same set of policies.

The DevicePolicyRules object is retrieved based on the value in the DeviceProfile that is fetched for the device. Once the DevicePolicyRules object has been retrieved, then the list of PolicyRules for that device can be retrieved. If any object is not found or if an error is detected during a consistency check on a object then the search is aborted and messages are displayed to the ELS (PLCY messages) identifying the error. If an error occurs, the network administrator may configure one of the following choices to handle it:

- Delete all locally read policies and revert to a drop or pass all rule
- Keep all locally read policies. Specify this option with the policy feature's **set default** command.

In either case, the search is attempted again at the configured retry interval. If the primary LDAP server cannot be contacted, then after 5 attempts the secondary

## Using the Policy Feature

server is tried. If the secondary server cannot be reached, then after 5 attempts the primary server is tried again. You can specify the retry interval with the policy feature's **set ldap retry-interval** command. If a search is failing because of network latency, you may change the search timeout from the default of 3 seconds using the policy feature's **set ldap search-timeout** command.

---

## Generating Rules

Configure a policy to specify how you want the network to operate. The router translates the policy information into a set of rules that it compares to traffic flows. In the past you may have done this manually by defining inbound and outbound packet filters for each traffic pattern. The policy database eliminates this, because with it you only configure a single policy.

Most of the work is done internally each time the policy database is built. In some cases a router translates a policy directly into a single rule. In the case of ISAKMP/IPSec, it translates a policy into five rules. Five rules are needed to account for the traffic directions (in and out) and for the control flows that occur during Phase 1 and Phase 2 of IKE negotiations. The relationship between policies and rules is as follows:

**One DiffServ policy → One DiffServ rule**

**One RSVP policy → One RSVP rule**

**One ISAKMP/IPSec policy → Five ISAKMP/IPSec rules**

Example: Secure the traffic from subnet A to subnet B; the tunnel endpoints are SGa and SGb.

1. Phase 1 Inbound (Profile = SGb to SGa, Proto UDP, Src Port 500, Dst Port 500): This rule is needed to filter incoming Phase 1 negotiations from the remote ISAKMP peer if the device is functioning as an ISAKMP responder.
2. Phase 1 Outbound (Profile = SGa to SGb, Proto UDP, Src Port 500, Dst Port 500): This rule is needed to filter the Phase 1 information needed if traffic initiates ISAKMP Phase 1 negotiations. In this case the device is functioning as an ISAKMP initiator.
3. Phase 2 Inbound (Profile = SGb to SGa, Proto UDP, Src Port 500, Dst Port 500): This rule is needed to filter incoming Phase 2 traffic from the remote ISAKMP peer. This traffic is the result of the remote peer initiating a Phase 2 refresh or initial negotiation. A Phase 2 outbound rule is not needed since the outbound traffic (rule 5) always starts the negotiations if needed.
4. Traffic Into the Secure Tunnel (Profile = Subnet A to Subnet B): This rule is needed to put unprotected traffic into a secure tunnel. If the security association has not been negotiated, then the Phase 1 rule is also gathered and IKE starts Phase 1 and Phase 2. Once the SAs have been established, then packets matching this rule are given to IPSec for encapsulation and transmission.
5. Traffic From the Secure Tunnel (Profile = Subnet B to Subnet A): This rule is needed to ensure that packets that should have arrived in a secure tunnel did indeed arrive in a secure tunnel. If the packet was not decapsulated by IPSec and encounters this rule, then the packet is dropped. This rule handles any traffic that is spoofed into the network.

**One IPSec manual-keyed tunnel → Two IPSec rules**

Example: Secure the traffic from subnet A to subnet B; the tunnel endpoints are SGa and SGb.

1. Traffic Into the Secure Tunnel (Profile = Subnet A to Subnet B): This rule is needed to put unprotected traffic into a secure tunnel. This is a statically configured tunnel so it is always available, and packets matching this rule are given directly to IPSec for encapsulation and transmission.
2. Traffic From the Secure Tunnel (Profile = Subnet B to Subnet A): This rule is needed to ensure that packets that should have arrived in a secure tunnel did indeed arrive in a secure tunnel. If the packet was not decapsulated by IPSec and encounters this rule, then the packet is dropped. This rule handles any traffic that is spoofed into the network.

You can view these rules using the policy feature's **list rule** monitoring command.

---

## Configuration Examples

The following examples show how you can use the policy feature to configure the routers in a network. First, access the policy feature as shown:

```
* talk 6
Config>feature policy
IP Network Policy configuration
```

## IPSec/ISAKMP Policy with QoS

You may enter policy information in either of two ways. The first way is to define the individual policy objects and then group them together. To use this method, first define the IPSec transforms, then the IPSec proposal (which refers to the IPSec transforms). Then define the IPSec action (which refers to the IPSec proposals), and so forth until you completely define the policy. Using Figure 31 as a reference, this method starts at the right side of the policy objects and works its way to the left.

The second approach, which you may find easier, is to define the high-level policy options first, and as you are prompted, enter the definitions for the individual policy objects as you go along. A sample configuration procedure follows Figure 31, and uses values that correspond to those in the figure. It uses the left-to-right method and starts with the **add policy** command.

If an object was defined previously that meets your needs, then you can reuse it instead of creating a new definition. For example, if a validity period for allTheTime was configured for a previous policy, then you may reuse it. The following procedure shows the entire process, but does not demonstrate the reuse of previously defined policy information. For an example of using previously defined information, see “IPSec/ISAKMP Only Policy” on page 293.

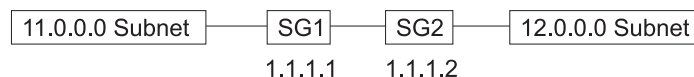

Figure 31. Configuring IPSec/ISAKMP with QoS

The policy configuration scenario described in the following text is from SG1's perspective. The policy statement is:

## Using the Policy Feature

Secure the traffic from subnet 11 to subnet 12 with the tunnel endpoints being SG1 and SG2, and provide a QoS for the traffic in this tunnel by means of DiffServ GoldService

1. Add the policy.

```
Policy config>add policy
Enter a Name (1-29 characters) for this Policy []? examplePolicySecure11to12
Enter the priority of this policy (This number is used to
determine the policy to enforce in the event of policy conflicts) [5]? 10
```

2. No profiles are configured so you must define a new one.

```
List of Profiles:
0: New Profile

Enter number of the profile for this policy [0]?
```

3. New profile definition; in this case the traffic we are interested in is from subnet 11 to subnet 12.

```
Enter a Name (1-29 characters) for this Profile []? trafficFrom11NetTo12Net
Source Address Format (1:NetMask, 2:Range, 3:Single Addr) [1]?
Enter IPV4 Source Address [0.0.0.0]? 11.0.0.0
Enter IPV4 Source Mask [255.0.0.0]?
Destination Address Format (1:NetMask, 2:Range, 3:Single Addr) [1]?
Enter IPV4 Destination Address [0.0.0.0]? 12.0.0.0
Enter IPV4 Destination Mask [255.0.0.0]?
```

```
Protocol IDs:
1) TCP
2) UDP
3) All Protocols
4) Specify Range
```

```
Select the protocol to filter on (1-4) [3]?
Enter the Starting value for the Source Port [0]?
Enter the Ending value for the Source Port [65535]?
Enter the Starting value for the Destination Port [0]?
Enter the Ending value for the Destination Port [65535]?
Enter the Mask to be applied to the Received DS-byte [0]?
Enter the value to match against after the Mask has
been applied to the Received DS-byte [0]?
Configure local and remote ID's for ISAKMP? [No]:
Limit this profile to specific interface(s)? [No]:
```

Here is the Profile you specified...

```
Profile Name      = trafficFrom11NetTo12Net
sAddr:Mask=      11.0.0.0 : 255.0.0.0      sPort=    0 : 65535
dAddr:Mask=      12.0.0.0 : 255.0.0.0      dPort=    0 : 65535
proto           =                0 : 255
TOS             =                x00 : x00
Remote Grp=All Users
Is this correct? [Yes]:
```

4. Finished with the profile definition and have returned to the policy configuration menu.

```
List of Profiles:
0: New Profile
1: trafficFrom11NetTo12Net

Enter number of the profile for this policy [1]? 1
```

5. No validity periods are configured so you must define a new one.

List of Validity Periods:  
0: New Validity Period

Enter number of the validity period for this policy [0]?

6. Validity period configuration questions; in this example the validity period is from 9 AM to 5 PM, Monday through Friday, every month of 1999.

Enter a Name (1-29 characters) for this Policy Valid Profile []?

**MonToFri-9am:5pm-1999**

Enter the lifetime of this policy. Please input the information in the following format:  
yyyymmddhhmmss:yyyymmddhhmmss OR '\*' denotes forever.

[\*]? **19990101000000:19991231000000**

During which months should policies containing this profile be valid. Please input any sequence of months by typing in the first three letters of each month with a space in between each entry, or type ALL to signify year round.

[ALL]?

During which days should policies containing this profile be valid. Please input any sequence of days by typing in the first three letters of each day with a space in between each entry, or type ALL to signify all week

[ALL]? **mon tue wed thu fri**

Enter the starting time (hh:mm:ss or \* denotes all day)

[\*]? **00:00:00**

Enter the ending time (hh:mm:ss)

[00:00:00]? **17:00:00**

Here is the Policy Validity Profile you specified...

```
Validity Name   = MonToFri-9am:5pm-1999
Duration       = 19990101000000 : 19991231000000
Months         = ALL
Days           = MON TUE WED THU FRI
Hours          = 09:00:00 : 17:00:00
Is this correct? [Yes]:
```

7. Finished with the validity period definition and have returned to the policy configuration menu.

List of Validity Periods:  
0: New Validity Period

1: MonToFri-9am:5pm-1999

Enter number of the validity period for this policy [1]? **1**

Should this policy enforce an IPSEC action? [No]: **yes**

8. Should always define a new IPsec action because the tunnel endpoint will always be different. The exceptions to this are if there are multiple tunnels between the same two gateways, and in the wildcarded remote access configurations where the tunnel endpoint is unknown.

IPSEC Actions:  
0: New IPSEC Action

Enter the Number of the IPSEC Action [0]?

9. IPsec action menu.

Enter a Name (1-29 characters) for this IPsec Action []? **secure11NetTo12Net**

List of IPsec Security Action types:

- 1) Block (block connection)
- 2) Permit

Select the Security Action type (1-2) [2]? **2**

Should the traffic flow into a secure tunnel or in the clear:

- 1) Clear
- 2) Secure Tunnel

## Using the Policy Feature

```
[2]?
Enter Tunnel Start Point IPV4 Address
[11.0.0.5]? 1.1.1.1
Enter Tunnel End Point IPV4 Address (0.0.0.0 for Remote Access)
[0.0.0.0]? 1.1.1.2
Does this IPSEC tunnel flow within another IPSEC tunnel? [No]:
Percentage of SA lifesize/lifetime to use as the acceptable minimum [75]?

Security Association Refresh Threshold, in percent (1-100) [85]?
Options for DF Bit in outer header (tunnel mode):
  1) Copy
  2) Set
  3) Clear
Enter choice (1-3) [1]?
Enable Replay prevention (1=enable, 2=disable) [2]?
Do you want to negotiate the security association at
system initialization(Y-N)? [No]:
You must choose the proposals to be sent/checked against during phase 2
negotiations. Proposals should be entered in order of priority.
```

10. No IPSec proposals defined so you must define a new one. Note that once the IPSec proposal has been defined it can be reused across multiple IPSec actions.

```
List of IPSEC Proposals:
0: New Proposal
```

```
Enter the Number of the IPSEC Proposal [0]?
```

11. IPSec proposal configuration.

```
Enter a Name (1-29 characters) for this IPsec Proposal []? genP2Proposal
Does this proposal require Perfect Forward Secrecy?(Y-N)? [No]:
Do you wish to enter any AH transforms for this proposal? [No]:
Do you wish to enter any ESP transforms for this proposal? [No]: yes
```

12. No ESP transforms are configured so you must define a new one. Once the ESP transform has been defined it may be reused by any IPSec proposal.

```
List of ESP Transforms:
0: New Transform
```

```
Enter the Number of the ESP transform [0]? 0
```

13. IPSec transform configuration.

```
Enter a Name (1-29 characters) for this IPsec Transform []? esp3DESswSHA
```

```
List of Protocol IDs:
```

- 1) IPSEC AH
- 2) IPSEC ESP

```
Select the Protocol ID (1-2) [1]? 2
```

```
List of Encapsulation Modes:
```

- 1) Tunnel
- 2) Transport

```
Select the Encapsulation Mode(1-2) [1]? 1
```

```
List of IPsec Authentication Algorithms:
```

- 0) None
- 1) HMAC-MD5
- 2) HMAC\_SHA

```
Select the ESP Authentication Algorithm (0-2) [2]? 2
```

```
List of ESP Cipher Algorithms:
```

- 1) ESP DES
- 2) ESP 3DES
- 3) ESP CDMF
- 4) ESP NULL



Select the ESP Cipher Algorithm (1-4) [1]? **2**  
 Security Association Lifesize, in kilobytes (1024-65535) [50000]?  
 Security Association Lifetime, in seconds (120-65535) [3600]?

Here is the IPsec transform you specified...

```
Transform Name = esp3DESswSHA
Type =ESP   Mode =Tunnel   LifeSize= 50000 LifeTime= 3600
Auth =SHA   Encr =3DES
Is this correct? [Yes]:
```

### 14. Return to the IPsec proposal menu.

List of ESP Transforms:  
 0: New Transform  
 1: esp3DESswSHA

Enter the Number of the ESP transform [1]?  
 Do you wish to add another ESP transform to this proposal? [Yes]: **no**

Here is the IPsec proposal you specified...

```
Name = genP2Proposal
Pfs = N
ESP Transforms:
esp3DESswSHA
Is this correct? [Yes]:
```

### 15. Return to the IPsec action menu.

List of IPSEC Proposals:  
 0: New Proposal  
 1: genP2Proposal

Enter the Number of the IPSEC Proposal [1]?  
 Are there any more Proposal definitions for this IPSEC Action? [No]:

Here is the IPsec Action you specified...

```
IPSECAction Name = secure11NetTo12Net
Tunnel Start:End = 1.1.1.1 : 1.1.1.2
Tunnel In Tunnel = No
Min Percent of SA Life = 75
Refresh Threshold = 85 %
Autostart = No
DF Bit = COPY
Replay Prevention = Disabled
IPSEC Proposals:
genP2Proposal
Is this correct? [Yes]:
```

### 16. Return to the policy menu.

IPSEC Actions:  
 0: New IPSEC Action  
 1: secure11NetTo12Net

Enter the Number of the IPSEC Action [1]? **1**

17. You have specified a secure IPsec action type, so you must identify an ISAKMP action for the Phase 1 negotiations. None are defined, so you must enter a new one. In most cases, one ISAKMP action and proposal is sufficient for all of the security policies.

## Using the Policy Feature

ISAKMP Actions:  
0: New ISAKMP Action

Enter the Number of the ISAKMP Action [0]?

### 18. ISAKMP action configuration.

Enter a Name (1-29 characters) for this ISAKMP Action []? genPhase1Action

List of ISAKMP Exchange Modes:  
1) Main  
2) Aggressive

Enter Exchange Mode (1-2) [1]?  
Percentage of SA lifesize/lifetime to use as the acceptable minimum [75]?

ISAKMP Connection Lifesize, in kilobytes (100-65535) [5000]?  
ISAKMP Connection Lifetime, in seconds (120-65535) [30000]?  
Do you want to negotiate the security association at  
system initialization(Y-N)? [Yes]: **no**  
You must choose the proposals to be sent/checked against during phase 1  
negotiations. Proposals should be entered in order of priority.

### 19. No ISAKMP proposals are configured, so you must create a new one.

List of ISAKMP Proposals:  
0: New Proposal

### 20. ISAKMP proposal configuration.

Enter the Number of the ISAKMP Proposal [0]?  
Enter a Name (1-29 characters) for this ISAKMP Proposal []? **genP1Proposal**

List of Authentication Methods:  
1) Pre-Shared Key  
2) RSA SIG

Select the authentication method (1-2) [1]? **2**

List of Hashing Algorithms:  
1) MD5  
2) SHA

Select the hashing algorithm(1-2) [1]? **2**

List of Cipher Algorithms:  
1) DES  
2) 3DES

Select the Cipher Algorithm (1-2) [1]? **2**  
Security Association Lifesize, in kilobytes (100-65535) [1000]?  
Security Association Lifetime, in seconds (120-65535) [15000]?

List of Diffie Hellman Groups:  
1) Diffie Hellman Group 1  
2) Diffie Hellman Group 2

Select the Diffie Hellman Group ID from this proposal (1-2) [1]?

Here is the ISAKMP Proposal you specified...

Name = genP1Proposal  
AuthMethod = Pre-Shared Key  
LifeSize = 1000  
LifeTime = 15000  
DHGroupID = 1  
Hash Algo = SHA  
Encr Algo = 3DES CB  
Is this correct? [Yes]:

## 21. Return to the ISAKMP action configuration.

```

List of ISAKMP Proposals:
0: New Proposal
1: genP1Proposal

Enter the Number of the ISAKMP Proposal [1]?
Are there any more Proposal definitions for this ISAKMP Action? [No]:

Here is the ISAKMP Action you specified...

ISAKMP Name      = genPhase1Action
Mode              =                  Main
Min Percent of SA Life =          75
Conn LifeSize:LifeTime =        5000 : 30000
Autostart         =                  No
ISAKMP Proposals:
genP1Proposal
Is this correct? [Yes]:

```

## 22. Return to the policy configuration.

```

ISAKMP Actions:
0: New ISAKMP Action
1: genPhase1Action

Enter the Number of the ISAKMP Action [1]?
Do you wish to Map a DiffServ Action to this Policy? [No]: yes

```

## 23. Define the DiffServ GoldService action.

```

DiffServ Actions:
0: New DiffServ Action

Enter the Number of the DiffServ Action [0]?

```

## 24. DiffServ action configuration.

```

If the DiffServ action is for the assured queue:

Enter a Name (1-29 characters) for this DiffServ Action [AF11]? GoldService
Enter the permission level for packets matching this DiffServ
Action (1. Permit, 2. Deny) [2]? 1
List of DiffServ Queues:
  1) Premium
  2) Assured/BE
Enter the Queue Number(1-2) for outgoing packets matching
this DiffServ Action [2]?
How do you want to specify the bandwidth allocated to this service?
Enter absolute kbps(1) or percentage of output bandwidth(2) [2]?
Enter the percentage of output bandwidth allocated to this service [10]? 20

List of Assured Forwarding Class:
  1) AF11 Class DS Byte
  2) AF21 Class DS Byte
  3) AF31 Class DS BYte
  4) AF41 Class DS Byte
  5) New Class DS Byte

Enter the AF Class (1-5) for outgoing packets matching
this DiffServ Action [5]? 1

List of Policing Type in AF Class:
  1) Single Rate Color Blind TCM
  2) Single Rate Color Aware TCM
  3) Two Rate Color Blind TCM
  4) Two Rate Color Aware TCM
  5) None
Enter the AF Class (1-5) Policing for outgoing packets matching
this DiffServ Action [5]? 1

Single Rate TCM:

```

## Using the Policy Feature

```
Committed Info Rate (CIR in bytes/sec) [0]? 25000
Committed Burst Size (CBS in bytes) [4000]?
Excess Burst Size (EBS in bytes) [4000]?
```

Here is the DiffServ Action you specified...

```
DiffServ Name   = GoldService                Type =Permit
               DS mask:modify=xFC:x20
               Queue:BwShare =Assured      : 20 %
               TCM:Class = SR,CB:AF11
               CIR = 25000 bytes/sec;   CBS = 4000 bytes
               EBS = 4000 bytes
```

Is this correct? [Yes]:

If the DiffServ action is for the premium queue:

```
Name (1-29 characters) for this DiffServ Action []? ExpService
Enter the permission level for packets matching this DiffServ
Action (1. Permit, 2. Deny) [2]? 1
List of DiffServ Queues:
  1) Premium
  2) Assured/BE
Enter the Queue Number(1-2) for outgoing packets matching
this DiffServ Action [2]? 1
How do you want to specify the bandwidth allocated to this service?
Enter absolute kbps(1) or percentage of output bandwidth(2) [2]?
Enter the percentage of output bandwidth allocated to this service [10]? 19
```

```
Transmitted DS-byte mask [0]? fc
Transmitted DS-byte modify value [0]? b8
```

```
List of EF Policing Config Type
  1) Default
  2) Custom
```

```
Enter the Parameter Type [1]? 2
Enter the Token Rate (in bytes/sec) [0]? 25000
Enter the Token Bucket Size (in bytes) [0]? 4000
```

Here is the DiffServ Action you specified...

```
DiffServ Name   = ExpService                Type =Permit
               DS mask:modify =xFC:xB8
               Queue:BwShare =Premium      : 19 %
               Token Rate:   = 25000 bytes/sec
               Token Bucket: = 4000 bytes
```

Is this correct? [Yes]:

### 25. Return to the policy configuration.

```
DiffServ Actions:
0: New DiffServ Action
1: GoldService
```

```
Enter the Number of the DiffServ Action [1]? 1
Policy Enabled/Disabled (1. Enabled, 2. Disabled) [1]?
```

Here is the Policy you specified...

```
Policy Name     = examplePolicySecure11to12
State:Priority   =Enabled      : 10
Profile         =trafficFrom10NetTo12Net
Valid Period    =MonToFri-9am:5pm-1999
IPSEC Action    =secure11NetTo12Net
ISAKMP Action   =genPhase1Action
DiffServ Action =GoldService
Is this correct? [Yes]:
```

26. If DiffServ or IPSec is not enabled, then you are alerted that before the policy can be enforced, you must enable DiffServ, IPSec, or both (DiffServ feature or IPSec feature).

You must enable and configure DiffServ in feature DS before QoS can be ensured for this policy

27. The final step in this process is to add a USER profile definition for the remote ISAKMP peer. This step is not needed if the ISAKMP negotiations are to authenticate the peer with public certificates. However in the preceding example we chose pre-shared key as the authentication method, so we must identify the user and enter the pre-shared key that we expect the peer to use.

```
Policy config>add user
Choose from the following ways to identify a user:
1: IP Address
2: Fully Qualified Domain Name
3: User Fully Qualified Domain Name
4: Key ID (Any string)
Enter your choice(1-4) [1]?
Enter the IP Address that distinguishes this user
[0.0.0.0]? 1.1.1.2
Group to include this user in []? peers
Authenticate user with 1:pre-shared key or 2: Public Certificate [1]?
Mode to enter key (1=ASCII, 2=HEX) [1]?
Enter the Pre-Shared Key (an even number of 2-128 ascii chars):
Enter the Pre-Shared Key again (10 characters) in ascii:
```

Here is the User Information you specified...

```
Name      = 1.1.1.2
Type      = IPV4 Addr
Group     = peers
Auth Mode =Pre-Shared Key
Key(Ascii)=exampleKey
Is this correct? [Yes]:
```

28. The policy configuration steps are now complete. If you want to configure DiffServ, IPSec, or any network or IP configuration, then you must do that before the IPSec tunnel will be functional. The following list command example shows the configuration that was just completed. To activate these changes, either reload the device or enter the policy feature's **reset database** monitoring command.

```
Policy config>list all

Configured Policies....

Policy Name      = examplePolicySecure11to12
State:Priority   =Enabled      : 10
Profile         =trafficFrom11NetTo12Net
Valid Period    =MonToFri-9am:5pm-1999
IPSEC Action    =secure11NetTo12Net
ISAKMP Action   =genPhase1Action
DiffServ Action =GoldService
--More--

Configured Profiles....

Profile Name     = trafficFrom11NetTo12Net
sAddr:Mask=     11.0.0.0 : 255.0.0.0      sPort=      0 : 65535
dAddr:Mask=     12.0.0.0 : 255.0.0.0      dPort=      0 : 65535
proto          =                0 : 255
TOS            =                x00 : x00
Remote Grp=A11 Users
--More--

Configured Validity Periods
```

## Using the Policy Feature

```
Validity Name = MonToFri-9am:5pm-1999
Duration = 19990101000000 : 19991231000000
Months = ALL
Days = MON TUE WED THU FRI
Hours = 09:00:00 : 17:00:00
--More--
```

Configured DiffServ Actions....

```
DiffServ Name = GoldService                Type =Permit

DS mask:modify=xFC:x20
Queue:BwShare =Assured      : 20 %
TCM:Class = SR, CB, AF11
CIR = 25000 bytes/sec; CBS = 4000 bytes
EBS = 4000 bytes
--More--
```

Configured IPSEC Actions....

```
IPSECAction Name = secure11NetTo12Net
Tunnel Start:End = 1.1.1.1 : 1.1.1.2
Tunnel In Tunnel = No
Min Percent of SA Life = 75
Refresh Threshold = 85 %
Autostart = No
DF Bit = COPY
Replay Prevention = Disabled
IPSEC Proposals:
genP2Proposal
--More--
```

Configured IPSEC Proposals....

```
Name = genP2Proposal
Pfs = N
ESP Transforms:
esp3DESswSHA
--More--
```

Configured IPSEC Transforms....

```
Transform Name = esp3DESswSHA
Type =ESP Mode =Tunnel LifeSize= 50000 LifeTime= 3600
Auth =SHA Encr =3DES
--More--
```

Configured ISAKMP Actions....

```
ISAKMP Name = genPhase1Action
Mode = Main
Min Percent of SA Life = 75
Conn LifeSize:LifeTime = 5000 : 30000
Autostart = No
ISAKMP Proposals:
genP1Proposal
--More--
```

Configured ISAKMP Proposals....

```
Name = genP1Proposal
AuthMethod = Pre-Shared Key
LifeSize = 1000
LifeTime = 15000
DHGroupID = 1
Hash Algo = SHA
Encr Algo = 3DES CB
--More--
```

Configured Policy Users....

```
Name = 1.1.1.2
Type = IPV4 Addr
Group =peers
Auth Mode =Pre-Shared Key
Key(Ascii)=exampleKey
--More--
```

Configured Manual IPSEC Tunnels....

IPv4 Tunnels					
ID	Name	Local IPv4 Addr	Rem IPv4 Addr	Mode	State
-----	-----	-----	-----	-----	-----

## IPSec/ISAKMP Only Policy

A sample configuration procedure, which follows Figure 32 and uses values that correspond to those in the figure, uses the left-to-right method and shows how to build on the previous sample procedure by reusing information that the previous one created.



Figure 32. Configuring IPsec and Reusing a Previous Definition

The policy configuration scenario described in the following text is from SG1's perspective. The policy statement in this scenario is:

Secure the traffic from subnet 11 to subnet 13 (TCP traffic only) with the tunnel endpoints being SG1 and SG3, and provide no QoS.

### 1. Add the policy.

```

Policy config>add policy
Enter a Name (1-29 characters) for this Policy []? examplePolicySecure11to13
Enter the priority of this policy (This number is used to
determine the policy to enforce in the event of policy conflicts) [5]? 10
List of Profiles:
0: New Profile
1: trafficFrom10NetTo12Net

Enter number of the profile for this policy [1]? 0
Enter a Name (1-29 characters) for this Profile []? trafficFrom11NetTo13Net
Source Address Format (1:NetMask, 2:Range, 3:Single Addr) [1]?
Enter IPV4 Source Address [0.0.0.0]? 11.0.0.0
Enter IPV4 Source Mask [255.0.0.0]?
Destination Address Format (1:NetMask, 2:Range, 3:Single Addr) [1]?
Enter IPV4 Destination Address [0.0.0.0]? 13.0.0.0
Enter IPV4 Destination Mask [255.0.0.0]?

Protocol IDs:
1) TCP
2) UDP
3) All Protocols
4) Specify Range

Select the protocol to filter on (1-4) [3]? 1
Enter the Starting value for the Source Port [0]?
Enter the Ending value for the Source Port [65535]?
Enter the Starting value for the Destination Port [0]?
Enter the Ending value for the Destination Port [65535]?
Enter the Mask to be applied to the Received DS-byte [0]?
Enter the value to match against after the Mask has
been applied to the Received DS-byte [0]?
Configure local and remote ID's for ISAKMP? [No]:
Limit this profile to specific interface(s)? [No]:
  
```

Here is the Profile you specified...

## Using the Policy Feature

```
Profile Name      = trafficFrom11NetTo13Net
sAddr:Mask=      11.0.0.0 : 255.0.0.0      sPort=    0 : 65535
dAddr:Mask=      13.0.0.0 : 255.0.0.0      dPort=    0 : 65535
proto           =          6 : 6
TOS             =          x00 : x00
Remote Grp=All Users
Is this correct? [Yes]:
List of Profiles:
0: New Profile
1: trafficFrom10NetTo12Net
2: trafficFrom11NetTo13Net

Enter number of the profile for this policy [1]? 2
```

### 2. Reuse the validity period.

```
List of Validity Periods:
0: New Validity Period
1: MonToFri-9am:5pm-1999

Enter number of the validity period for this policy [1]?
Should this policy enforce an IPSEC action? [No]: yes
IPSEC Actions:
0: New IPSEC Action
1: secure11NetTo12Net

Enter the Number of the IPSEC Action [1]? 0
Enter a Name (1-29 characters) for this IPsec Action []? secure11To13
List of IPsec Security Action types:
  1) Block (block connection)
  2) Permit

Select the Security Action type (1-2) [2]?
Should the traffic flow into a secure tunnel or in the clear:
  1) Clear
  2) Secure Tunnel
[2]?
Enter Tunnel Start Point IPV4 Address
[11.0.0.5]? 1.1.1.1
Enter Tunnel End Point IPV4 Address (0.0.0.0 for Remote Access)
[0.0.0.0]? 1.1.1.3
Does this IPSEC tunnel flow within another IPSEC tunnel? [No]:
Percentage of SA lifiesize/lifetime to use as the acceptable minimum [75]?

Security Association Refresh Threshold, in percent (1-100) [85]?
Options for DF Bit in outer header (tunnel mode):
  1) Copy
  2) Set
  3) Clear
Enter choice (1-3) [1]?
Enable Replay prevention (1=enable, 2=disable) [2]?
Do you want to negotiate the security association at
system initialization(Y-N)? [No]:
You must choose the proposals to be sent/checked against during phase 2
negotiations. Proposals should be entered in order of priority.
```

### 3. Reuse the IPsec proposal from the previously defined configuration.

```
List of IPSEC Proposals:
0: New Proposal
1: genP2Proposal

Enter the Number of the IPSEC Proposal [1]?
Are there any more Proposal definitions for this IPSEC Action? [No]:
```



Here is the IPsec Action you specified...

```
IPSECAction Name = secure11To13
Tunnel Start:End      =      1.1.1.1 : 1.1.1.3
Tunnel In Tunnel      =      No
Min Percent of SA Life =      75
Refresh Threshold     =      85 %
Autostart             =      No
DF Bit                =      COPY
Replay Prevention     =      Disabled
IPSEC Proposals:
genP2Proposal
Is this correct? [Yes]:
IPSEC Actions:
0: New IPSEC Action
1: secure11NetTo12Net
2: secure11To13
```

Enter the Number of the IPSEC Action [1]? 2

#### 4. Reuse the ISAKMP action from the previous configuration.

```
ISAKMP Actions:
0: New ISAKMP Action
1: genPhase1Action
```

```
Enter the Number of the ISAKMP Action [1]?
Do you wish to Map a DiffServ Action to this Policy? [No]:
Policy Enabled/Disabled (1. Enabled, 2. Disabled) [1]?
```

Here is the Policy you specified...

```
Policy Name      = examplePolicySecure11to13
State:Priority   =Enabled   : 10
Profile         =trafficFrom11NetTo13Net
Valid Period    =MonToFri-9am:5pm-1999
IPSEC Action    =secure11To13
ISAKMP Action   =genPhase1Action
Is this correct? [Yes]:
```

## Drop All Public Traffic (Filter Rule)

This policy example shows how to configure a simple drop rule for the public interface that drops all traffic that is not secured through IPsec. This rule is very general and **must** have the lowest priority of any rule configured.

### 1. Add the policy.

```
Policy config>add policy
Enter a Name (1-29 characters) for this Policy []? dropAllPublicTraffic
Enter the priority of this policy (This number is used to
determine the policy to enforce in the event of policy conflicts) [5]?
List of Profiles:
0: New Profile
1: trafficFrom10NetTo12Net
2: trafficFrom11NetTo13Net
```

Enter number of the profile for this policy [1]? 0

### 2. Define a new profile that includes all traffic going in or out the public interface (1.1.1.1).

## Using the Policy Feature

```
Enter a Name (1-29 characters) for this Profile []? allPublicTraffic
Source Address Format (1:NetMask, 2:Range, 3:Single Addr) [1]?
Enter IPV4 Source Address [0.0.0.0]?
Enter IPV4 Source Mask [0.0.0.0]?
Destination Address Format (1:NetMask, 2:Range, 3:Single Addr) [1]?
Enter IPV4 Destination Address [0.0.0.0]?
Enter IPV4 Destination Mask [0.0.0.0]?
```

```
Protocol IDs:
 1) TCP
 2) UDP
 3) All Protocols
 4) Specify Range
```

```
Select the protocol to filter on (1-4) [3]?
Enter the Starting value for the Source Port [0]?
Enter the Ending value for the Source Port [65535]?
Enter the Starting value for the Destination Port [0]?
Enter the Ending value for the Destination Port [65535]?
Enter the Mask to be applied to the Received DS-byte [0]?
Enter the value to match against after the Mask has
been applied to the Received DS-byte [0]?
Configure local and remote ID's for ISAKMP? [No]:
```

3. Since the source and destination (or both) information has been wild-carded out, you must specify the interfaces on which you expect this traffic to arrive and leave.

```
The Source and/or Destination Address information you specified
includes all addresses. You must specify an Interface Pair
with this profile to further qualify what traffic you wish to filter
to this policy. The interface pair should at least specify the
Limit this profile to specific interface(s)? [No]: yes
Interface Pair Groups:
0: New Ifc Pair
Number of Ifc Pair Group [1]? 0
```

4. Add an interface-pair for traffic going out over the public interface.

```
Enter a Group Name (1-29 characters) for this Interface Pair []? inOutPublic
Ingress Interface IP Address (255.255.255.255 = any ingress)
[255.255.255.255]?
Egress Interface IP Address (255.255.255.255 = any egress)
[255.255.255.255]? 1.1.1.1
Interface Pair Groups:
0: New Ifc Pair
1) Group Name: inOutPublic
   In:Out=255.255.255.255 : 1.1.1.1

Number of Ifc Pair Group [1]? 0
```

5. Add another interface-pair for traffic coming in over the public interface. Give it the same name as the previous interface pair to assign it to the same group.

```
Enter a Group Name (1-29 characters) for this Interface Pair []? inOutPublic
Ingress Interface IP Address (255.255.255.255 = any ingress)
[255.255.255.255]? 1.1.1.1
Egress Interface IP Address (255.255.255.255 = any egress)
[255.255.255.255]?
Interface Pair Groups:
0: New Ifc Pair
1) Group Name: inOutPublic
   In:Out=255.255.255.255 : 1.1.1.1
   In:Out=      1.1.1.1 : 255.255.255.255
```

Number of Ifc Pair Group [1]?

Here is the Profile you specified...

```

Profile Name      = allPublicTraffic
sAddr:Mask=      0.0.0.0 : 0.0.0.0          sPort=    0 : 65535
dAddr:Mask=      0.0.0.0 : 0.0.0.0          dPort=    0 : 65535
proto            =                0 : 255
TOS              =                x00 : x00
Remote Grp=All Users
1. In:Out=255.255.255.255 : 1.1.1.1
2. In:Out=      1.1.1.1 : 255.255.255.255
Is this correct? [Yes]:
List of Profiles:
0: New Profile
1: trafficFrom10NetTo12Net
2: trafficFrom11NetTo13Net
3: allPublicTraffic

```

Enter number of the profile for this policy [1]? **3**

## 6. Add a new validity period that specifies all the time.

List of Validity Periods:

```

0: New Validity Period
1: MonToFri-9am:5pm-1999

```

Enter number of the validity period for this policy [1]? **0**

Enter a Name (1-29 characters) for this Policy Valid Profile []? **allTheTime**

Enter the lifetime of this policy. Please input the information in the following format:

yyyymmddhhmmss:yyyymmddhhmmss OR '\*' denotes forever.

[\*]?

During which months should policies containing this profile be valid. Please input any sequence of months by typing in the first three letters of each month with a space in between each entry, or type ALL to signify year round.

[ALL]?

During which days should policies containing this profile be valid. Please input any sequence of days by typing in the first three letters of each day with a space in between each entry, or type ALL to signify all week

[ALL]?

Enter the starting time (hh:mm:ss or \* denotes all day)

[\*]?

Here is the Policy Validity Profile you specified...

```

Validity Name    = allTheTime
Duration        = Forever
Months          = ALL
Days            = ALL
Hours           = All Day
Is this correct? [Yes]:
List of Validity Periods:
0: New Validity Period
1: MonToFri-9am:5pm-1999
2: allTheTime

```

Enter number of the validity period for this policy [1]? **2**

Should this policy enforce an IPSEC action? [No]: **yes**

IPSEC Actions:

```

0: New IPSEC Action

```

## Using the Policy Feature

```
1: secure11NetTo12Net
2: secure11To13
```

### 7. Add a new IPsec action to drop all traffic (filter action).

```
Enter the Number of the IPSEC Action [1]? 0
Enter a Name (1-29 characters) for this IPsec Action []? dropTraffic
List of IPsec Security Action types:
  1) Block (block connection)
  2) Permit
```

```
Select the Security Action type (1-2) [2]? 1
```

Here is the IPsec Action you specified...

```
IPSECAction Name = dropTraffic
Action           = Drop
Is this correct? [Yes]:
IPSEC Actions:
0: New IPSEC Action
1: secure11NetTo12Net
2: secure11To13
3: dropTraffic
```

```
Enter the Number of the IPSEC Action [1]? 3
Do you wish to Map a DiffServ Action to this Policy? [No]:
Policy Enabled/Disabled (1. Enabled, 2. Disabled) [1]?
```

Here is the Policy you specified...

```
Policy Name      = dropAllPublicTraffic
State:Priority   =Enabled      : 5
Profile         =allPublicTraffic
Valid Period    =allTheTime
IPSEC Action    =dropTraffic
Is this correct? [Yes]:
```

## Configuring and Enabling the LDAP Policy Search Engine

This example shows how to configure and enable the LDAP policy search engine. In this example there are two LDAP directories (a primary and a secondary) with IP addresses of 11.0.0.2 and 13.0.0.1 respectively. They are both listening on TCP port 389 and the device must bind to the LDAP server as `cn=router`, password `myPassWord`. The base entry in the directory tree for the router's policies is `cn=RouterDeviceProfile,o=ibm,c=us`.

**Note:** Currently both the primary and secondary LDAP servers must be listening on the same port and have the same authentication credentials for the router.

The DeviceProfile must be the same for the router in both directory servers. This example also shows how to set the default policy so that the LDAP communications are secured through IPsec. This example uses pre-shared key for the ISAKMP authentication, and SHA and 3DES for the authentication and encryption parameters for Phase 1 and Phase 2. The tunnel startpoint is 1.1.1.4 for the device performing the LDAP policy search, and the tunnel endpoints are 1.1.1.1 for the 11.0.0.1 LDAP server, and 1.1.1.3 for the 13.0.0.1 LDAP server.

### 1. Configure and enable the LDAP policy search engine, and list the results.

```
Policy config>set ldap primary-server 11.0.0.1
Policy config>set ldap secondary-server 13.0.0.1
Policy config>set ldap port 389
Policy config>set ldap bind-name cn=router
```

```

Policy config>set ldap bind-pw myPassWord
Policy config>set ldap anonymous-bind no
Policy config>set ldap policy-base cn=RouterDeviceProfile,o=ibm,c=us
Policy config>enable ldap policy-search
Policy config>list ldap
LDAP CONFIGURATION information:

Primary Server Address:          11.0.0.1
Secondary Server Address:       13.0.0.1

Search timeout value:           3 sec(s)
Retry interval on search failures: 1 min(s)
Server TCP port number:        389
Server Version number:         2

Bind Information:
Bind Anonymously:              No
  Device Distinguished Name:    cn=router
  Device Password:              myPassWord

Base DN for this device's policies:  cn=RouterDeviceProfile,o=ibm,c=us

Search policies from LDAP Directory: Enabled

```

### 2. Set the default policy

```

Policy config>set default-policy
List of default policy rules:
  1) Accept and Forward all IP Traffic
  2) Permit LDAP traffic, drop all other IP Traffic
  3) Permit and Secure LDAP traffic, drop all other IP Traffic

Select the default policy rule to use during policy refresh periods [1]? 3
List of default error handling procedures:
  1) Reset Policy Database to Default Rule
  2) Flush any rules read from LDAP, load local rules

Select the error handling behavior for when loading Policy Database [1]?

Please enter the set of Security Information for encrypting and
authenticating the LDAP traffic generated by the device when
retrieving policy information from the LDAP Server

Enter phase 1 ISAKMP negotiation parameters:

List of Diffie Hellman Groups:
  1) Diffie Hellman Group 1
  2) Diffie Hellman Group 2

Select the Diffie Hellman Group ID from this proposal (1-2) [1]?

List of Hashing Algorithms:
  1) MD5
  2) SHA

Select the hashing algorithm(1-2) [1]? 2

List of Cipher Algorithms:
  1) DES
  2) 3DES

Select the Cipher Algorithm (1-2) [1]? 2

```

## Using the Policy Feature

```
Authentication: (1)Pre-shared Key or (2)Certificate(RSA Sig) [2]? 1
Enter the Pre-Shared Key []? test

Enter phase 2 IPSEC negotiation parameters:
List of IPsec Authentication Algorithms:
  0) None
  1) HMAC-MD5
  2) HMAC_SHA

Select the ESP Authentication Algorithm (0-2) [1]? 2
List of ESP Cipher Algorithms:
  1) ESP DES
  2) ESP 3DES
  3) ESP CDMF
  4) ESP NULL

Select the ESP Cipher Algorithm (1-4) [1]? 2
Tunnel Start IPV4 Address (Primary LDAP Server)
[0.0.0.0]? 1.1.1.4
Tunnel End Point IPV4 Address (Primary LDAP Server)
[0.0.0.0]? 1.1.1.1
Tunnel Start IPV4 Address (Secondary LDAP Server)
[1.1.1.4]?
Tunnel End Point IPV4 Address (Secondary LDAP Server)
[1.1.1.1]? 1.1.1.3
Policy config>list default-policy

Default Policy Rule:                Drop All IP Traffic except secure LDAP
Default error handling procedure:    Reset Policy Database to Default Rule

Phase 1 ISAKMP negotiation parameters:
Diffie Hellman Group ID:            1
Hashing Algorithm:                  SHA
ISAKMP Cipher Algorithm:            ESP 3DES CBC
Per-shared key value:               test

Phase 2 IPSEC negotiation parameters:
IPsec ESP Authentication Algorithm:  HMAC SHA
ESP Cipher Algorithm:               3DES
Local Tunnel Addr (Primary Server):  1.1.1.4
Remote Tunnel Addr (Primary Server):  1.1.1.1
Local Tunnel Addr (Secondary Server):  1.1.1.4
Remote Tunnel Addr (Secondary Server): 1.1.1.3
```

At this point you are ready to manage the routers in your network with the policy feature. For detailed information about the commands used to configure the required policy parameters such as profiles, proposals, transforms, and actions, see “Policy Configuration Commands” on page 309, “LDAP Policy Server Configuration Commands” on page 327, and “Policy Monitoring Commands” on page 332.

## Policy Quick Config Example

The **qconfig** command available in the policy feature allows you to quickly add a policy based on one of four scenarios. You are asked a few simple questions. Then, based on your responses, the policy objects are generated. The **qconfig** command takes advantage of the pre-defined policy templates to minimize the configuration questions you are asked. You cannot change the policy objects through **qconfig**; it is only a means to add a policy quickly. See “Policy Configuration Commands” on page 309 for more information on this command.

The following example replicates the IPSec/ISAKMP example that was described earlier in this chapter. Basically, the objective is to protect and authenticate the

## Using the Policy Feature

traffic from the 11.0.0.0 subnet to the 12.0.0.0 subnet with SG1 and SG2. Additionally, the traffic that is secured through these security gateways should be provided a QoS. In this example, the QoS is AF11 and strong security is selected.

Policy config>**qconfig**

Enter a Name (1-29 characters) for this Policy [policyQC\_1]?

Please choose from one of the following Scenarios:

- 1: Branch Office Scenario
- 2: Remote Access User Scenario (IPSEC and L2TP)
- 3: Drop Traffic not matched on Untrusted Interface
- 4: Custom

Selection [1]?

Local Subnet (Base Address) [0.0.0.0]? **11.0.0.0**

Local Subnet (Net Mask) [255.0.0.0]?

Local Tunnel Endpoint [11.0.0.5]? **1.1.1.1**

Remote Subnet (Base Address) [0.0.0.0]? **12.0.0.0**

Remote Subnet (Net Mask) [255.0.0.0]?

Remote Tunnel Endpoint [0.0.0.0]? **1.1.1.2**

Configure Ports and Protocols? [No]:

- 1: Strong Security, 2: Very Strong Security, 3: Help [1]?

Authenticate Peer using 1:Pre-shared Key or 2:Certificate(RSA Signatures) [2]? **1**

Enter the Pre-Shared Key (an even number of 2-128 ascii chars):

Enter the Pre-Shared Key again (4 characters) in ascii:

Select from the following DiffServ Actions:

0: Best Effort (No DiffServ)

1: EF

2: AF11

3: AF21

4: AF31

5: AF41

6: GoldService

Enter Selection [0]? **2**

Configure advanced options? [No]:

Here is the information you entered...

Policy Name: policyQC\_1 (Branch Office Scenario)

Local Information:

-----

Subnet: 11.0.0.0/255.0.0.0

Tunnel Endpoint: 1.1.1.1

Port Range: 00000-65535

Remote Information:

-----

Subnet: 12.0.0.0/255.0.0.0

Tunnel Endpoint: 1.1.1.2

Port Range: 00000-65535

Other Information:

-----

Protocol: 000-255

Priority: 10

Security: Strong Security

Encap Mode: Tunnel

Auth Mode: Pre-Shared Key

Validity Period: allTheTime

DiffServ Action: AF11

Continue? [Yes]:

-----

Based on the input to these simple questions, the QCONFIG mechanism generated the following object

1.

## Using the Policy Feature

```
Policy config>list policy by-name policyQC_1
```

```
Policy Name      = policyQC_1
State:Priority   =Enabled    : 10
Profile         =policyQC_1
Valid Period    =allTheTime
IPSEC Action    =policyQC_1
ISAKMP Action  =generalPhase1Action
DiffServ Action=AF11
```

2.

```
Policy config>list ipsec-action by-name policyQC_1
```

```
IPSECAction Name = policyQC_1
Tunnel Start:End =      1.1.1.1 : 1.1.1.2
Tunnel In Tunnel =      No
Min Percent of SA Life =      1
Refresh Threshold =      85 %
Autostart        =      No
DF Bit           =      COPY
Replay Prevention =      Disabled
IPSEC Proposals:
  strongP2EspProp
  strongP2EspAhProp
  veryStrongP2EspProp
  veryStrongP2EspAhProp
```

3.

```
Policy config>list profile by-name policyQC_1
```

```
Profile Name      = policyQC_1
sAddr:Mask=      11.0.0.0 : 255.0.0.0      sPort=      0 : 65535
dAddr:Mask=      12.0.0.0 : 255.0.0.0      dPort=      0 : 65535
proto           =      0 : 255
TOS             =      x00 : x00
Remote Grp=All Users
```

4.

```
Policy config>list user by-name
```

```
List of Users:
  num: User Info                               :Group Name
  1: 1.1.1.2                                   :IKE-Peers
Enter the number of user [1]?
Name      = 1.1.1.2
Type      = IPV4 Addr
Group     =IKE-Peers
Auth Mode =Pre-Shared Key
```

## Predefined Policy Objects

The following policy objects have been predefined for your use. These objects represent the most typical configurations and are intended to be usable for many policy configurations. These predefined policy object definitions, along with the **qconfig** command provide an easy way to add policies into a network configuration. You cannot change or delete the predefined templates. If you want to change an object, you must copy it using the **copy** command, specifying a new name. Once you have done that, you may change the copy. If you upgrade to a new release or to a PTF version of the code and there has been a change to the templates, you need to use the policy feature **refresh-templates** configuration command to get the most current templates; otherwise the original definitions will continue to be used.

The following predefined objects exist for the policy feature:



**Validity Periods**

The following validity period objects are predefined:

```

Validity Name = allTheTime
  Duration = Forever
  Months = ALL
  Days = ALL
  Hours = All Day

Validity Name = allTheTimeMonThruFri
  Duration = Forever
  Months = ALL
  Days = MON TUE WED THU FRI
  Hours = All Day

Validity Name = 9to5MonThruFri
  Duration = Forever
  Months = ALL
  Days = MON TUE WED THU FRI
  Hours = 09:00:00 : 17:00:00

Validity Name = 5to9MonThruFri
  Duration = Forever
  Months = ALL
  Days = MON TUE WED THU FRI
  Hours = 17:00:00 : 09:00:00

```

**DiffServ Actions**

The following DiffServ action objects are predefined:

```

DiffServ Name = EF                                     Type =Permit
  DS mask:modify =xFC:xB8
  Queue:BwShare =Premium      : 19 %
  Token Rate: = 0 bytes/sec
  Token Bucket: = 0 bytes

DiffServ Name = AF11                                   Type =Permit
  DS mask:modify =xFC:x28
  Queue:BwShare =Assured      : 15 %
  No Policing Selected

DiffServ Name = AF21                                   Type =Permit
  DS mask:modify =xFC:x48
  Queue:BwShare =Assured      : 10 %
  No Policing Selected

DiffServ Name = AF31                                   Type =Permit
  DS mask:modify =xFC:x68
  Queue:BwShare =Assured      : 10 %
  No Policing Selected

DiffServ Name = AF41                                   Type =Permit
  DS mask:modify =xFC:x88
  Queue:BwShare =Assured      : 5 %

```

**IPSec Actions**

The following IPSec action objects are predefined:

```

IPSECAction Name = ipsecDropTraffic
  Action = Drop

IPSECAction Name = ipsecPassTrafficClear
  Action = Clear

```

## Using the Policy Feature

### IPSec Proposals for IKE Phase 2

The following IPSec proposal objects for IKE Phase 2 are predefined:

```
Name = strongP2EspProp
      Pfs = N
      ESP Transforms:
          espTunnelMD5andDES
          espTunnelSHAandDES

Name = strongP2EspAhProp
      Pfs = N
      AH Transforms:
          ahTunnelMD5
          ahTunnelSHA
      ESP Transforms:
          espTunnelDES

Name = veryStrongP2EspProp
      Pfs = N
      ESP Transforms:
          espTunnelSHAand3DES
          espTunnelMD5and3DES

Name = veryStrongP2EspAhProp
      Pfs = N
      AH Transforms:
          ahTunnelSHA
          ahTunnelMD5
      ESP Transforms:
          espTunnel3DES

Name = veryStrongP2EspPropPFS
      Pfs = Y      DHGrp= 1
      ESP Transforms:
          espTunnelSHAand3DES
          espTunnelMD5and3DES

Name = strongP2EspPropXport
      Pfs = N
      ESP Transforms:
          espTransportMD5andDES
          espTransportSHAandDES

Name = strongP2EspAhPropXport
      Pfs = N
      AH Transforms:
          ahTransportMD5
          ahTransportSHA
      ESP Transforms:
          espTransportDES

Name = veryStrongP2EspPropXport
      Pfs = N
      ESP Transforms:
          espTransportSHAand3DES
          espTransportMD5and3DES

Name = strongP2EspAhPropXport
      Pfs = N
      AH Transforms:
          ahTransportMD5
          ahTransportSHA
      ESP Transforms:
          espTransportDES

Name = veryStrongP2EspPropXport
      Pfs = N
```

```

ESP Transforms:
    espTransportSHAand3DES
    espTransportMD5and3DES

Name = veryStrongP2EspAhPropXport
Pfs = N
AH Transforms:
    ahTransportSHA
    ahTransportMD5
ESP Transforms:
    espTransport3DES

Name = veryStrongP2EspPropXport
Pfs = N
ESP Transforms:
    espTransportSHAand3DES
    espTransportMD5and3DES

Name = veryStrongP2EspAhPropXport
Pfs = N
AH Transforms:
    ahTransportSHA
    ahTransportMD5
ESP Transforms:
    espTransport3DES

Name = veryStrongP2EspPropPFSXport
Pfs = Y    DHGrp= 1
ESP Transforms:
    espTransportSHAand3DES
    espTransportMD5and3DES

Name = veryStrongP2EspAhPropPFSXport
Pfs = Y    DHGrp= 1
AH Transforms:
    ahTransportSHA
    ahTransportMD5
ESP Transforms:
    espTransport3DES

```

## IPSec Transforms

The following IPSec transform objects are predefined:

```

Transform Name = ahTransportMD5
Type =AH      Mode =Transport  LifeSize= 50000 LifeTime= 3600
Auth =MD5     Encr =None

Transform Name = ahTransportSHA
Type =AH      Mode =Transport  LifeSize= 50000 LifeTime= 3600
Auth =SHA     Encr =None

Transform Name = ahTunnelMD5
Type =AH      Mode =Tunnel     LifeSize= 50000 LifeTime= 3600
Auth =MD5     Encr =None

Transform Name = ahTunnelSHA
Type =AH      Mode =Tunnel     LifeSize= 50000 LifeTime= 3600
Auth =SHA     Encr =None

Transform Name = espTunnelMD5andDES
Type =ESP     Mode =Tunnel     LifeSize= 50000 LifeTime= 3600
Auth =MD5     Encr =DES

Transform Name = espTunnelSHAandDES
Type =ESP     Mode =Tunnel     LifeSize= 50000 LifeTime= 3600
Auth =SHA     Encr =DES

```

## Using the Policy Feature

```
Transform Name = espTunnelMD5and3DES
  Type =ESP   Mode =Tunnel   LifeSize= 50000 LifeTime= 3600
  Auth =MD5   Encr =3DES

Transform Name = espTunnelSHAand3DES
  Type =ESP   Mode =Tunnel   LifeSize= 50000 LifeTime= 3600
  Auth =SHA   Encr =3DES

Transform Name = espTunnelDES
  Type =ESP   Mode =Tunnel   LifeSize= 50000 LifeTime= 3600
  Auth =None  Encr =DES

Transform Name = espTunnel3DES
  Type =ESP   Mode =Tunnel   LifeSize= 50000 LifeTime= 3600
  Auth =None  Encr =3DES

Transform Name = espTransportMD5andDES
  Type =ESP   Mode =Transport LifeSize= 50000 LifeTime= 3600
  Auth =MD5   Encr =DES

Transform Name = espTransportSHAandDES
  Type =ESP   Mode =Transport LifeSize= 50000 LifeTime= 3600
  Auth =SHA   Encr =DES

Transform Name = espTransportMD5and3DES
  Type =ESP   Mode =Transport LifeSize= 50000 LifeTime= 3600
  Auth =MD5   Encr =3DES

Transform Name = espTransportSHAand3DES
  Type =ESP   Mode =Transport LifeSize= 50000 LifeTime= 3600
  Auth =SHA   Encr =3DES

Transform Name = espTransportDES
  Type =ESP   Mode =Transport LifeSize= 50000 LifeTime= 3600
  Auth =None  Encr =DES

Transform Name = espTransport3DES
  Type =ESP   Mode =Transport LifeSize= 50000 LifeTime= 3600
  Auth =None  Encr =3DES
```

## ISAKMP Actions

The following ISAKMP action objects are predefined:

```
ISAKMP Name = generalPhase1Action
  Mode = Main
  Min Percent of SA Life = 1
  Conn LifeSize:LifeTime = 5000 : 30000
  Autostart = No
  ISAKMP Proposals:
    veryStrongP1PropRSACert
    strongP1PropRSACert
    veryStrongP1PropSharedKey
    strongP1PropSharedKey
```

## ISAKMP Proposals

The following ISAKMP proposal objects are predefined:

```
Name = strongP1PropSharedKey
  AuthMethod = Pre-Shared Key
  LifeSize = 1000
  LifeTime = 15000
  DHGroupID = 1
  Hash Algo = MD5
  Encr Algo = DES CBC
```

```
Name = strongP1PropRSACert
  AuthMethod = Certificate (RSA SIG)
  LifeSize   = 1000
  LifeTime   = 15000
  DHGroupID  = 1
  Hash Algo  = MD5
  Encr Algo  = DES CBC
```

```
Name = veryStrongP1PropSharedKey
  AuthMethod = Pre-Shared Key
  LifeSize   = 1000
  LifeTime   = 15000
  DHGroupID  = 1
  Hash Algo  = SHA
  Encr Algo  = 3DES CB
```

```
Name = veryStrongP1PropRSACert
  AuthMethod = Certificate (RSA SIG)
  LifeSize   = 1000
  LifeTime   = 15000
  DHGroupID  = 1
  Hash Algo  = SHA
  Encr Algo  = 3DES CB
```

## Using the Policy Feature

---

## Chapter 19. Configuring and Monitoring the Policy Feature

This chapter describes the LDAP and policy commands provided by the policy feature for configuring and operating the router devices in a network. It includes the following sections:

- “Accessing the Policy Configuration Prompt”
- “Policy Configuration Commands”
- “LDAP Policy Server Configuration Commands” on page 327
- “Accessing the Policy Monitoring Prompt” on page 332
- “Policy Monitoring Commands” on page 332
- “Policy Dynamic Reconfiguration Support” on page 337

---

### Accessing the Policy Configuration Prompt

To enter policy configuration commands:

1. Enter **talk 6** at the OPCON (\*) prompt.
2. Enter **feature policy** at the Config> prompt.

The Policy config> prompt displays. You may now enter policy configuration commands.

---

### Policy Configuration Commands

These commands enable you to configure the information contained in policies. Table 38 summarizes the policy configuration commands and the rest of this section describes them in detail. Enter these commands at the Policy config> prompt. You can either enter the command and options on one line, or enter only the command and respond to the prompts. To see a list of valid command options, enter the command with a question mark instead of options.

Table 38. Policy Configuration Commands

Command	Function
? (Help)	Displays all the commands available for this command level or lists the options for specific commands (if available). See “Getting Help” on page xxxii.
Add	Adds the information used to create a policy.
Change	Changes the information making up a policy.
Copy	Copies information from one policy into another.
Delete	Deletes information from a policy.
Disable	Disables a policy.
Enable	Enables a policy.
List	Displays the information in a policy.
Qconfig	Enables you to add a policy based on predefined templates.
refresh-templates	Enables you to install or remove the most current templates for the version of code running on a specific platform. This makes it easier for you to change between various software release and PTF levels, simplifying the decision to do so.
Exit	Returns you to the previous command level. See “Exiting a Lower Level Environment” on page xxxii.

#### Add

Use the **add** command to add information to a policy.

**Syntax:** add diffserv-action  
interface-pair

## Policy Configuration Commands (Talk 6)

ipsec-action  
ipsec-manual-tunn  
ipsec-proposal  
ipsec-transform  
isakmp-action  
isakmp-proposal  
policy  
profile  
rsvp-action  
user  
validity-period

### **diffserv-action**

Prompts you for information about which DiffServ-action selections apply. See “Chapter 22. Using the Differentiated Services Feature” on page 391 and “Chapter 23. Configuring and Monitoring the Differentiated Services Feature” on page 399 for details.

**name** The unique name of the DiffServ action for the policy.

#### **permission level**

Specifies whether the router is to forward packets that match this DiffServ action.

- 1 Permit
- 2 Deny

**Default value:** 2

#### **queue number**

The queue into which outgoing packets matching this DiffServ action are placed.

- 1 Premium (EF)
- 2 Assured (AF)/Best Effort

**Default value:** 2

#### **bwshare type**

The type of bandwidth share allocation.

- 1 Absolute (in kbps)
- 2 Percentage (of total output bandwidth)

**Default value:** 2

#### **bwshare**

The bandwidth (in kbps or as a percentage of output bandwidth) allocated to this service.

## **Assured Forwarding**

### **Assured forwarding class**

Specifies the assured forwarding class for outgoing packets matching this DiffServ action.

- 1 AF1 Class DS Byte
- 2 AF2 Class DS Byte



## Policy Configuration Commands (Talk 6)

- 3 AF3 Class DS Byte
- 4 AF4 Class DS Byte
- 5 New Class

### Assured forwarding policing type

Specifies the type of AF policing for outgoing packets matching this DiffServ action.

- 1 Single-rate, color-blind TCM
- 2 Single-rate, color-aware TCM
- 3 Two-rate, color-blind TCM
- 4 Two-rate, color-aware TCM
- 5 None

### Single-Rate TCM Parameters

#### Committed information rate (CIR)

Specifies the committed information rate.

#### Committed burst size (CBS)

Specifies the committed burst size.

#### Excess burst size (EBS)

Specifies the excess burst size.

#### Notes:

1. Specify the CIR in bytes of IP packets per second. This includes the IP header, but not the link-specific header.
2. Specify the CBS and the EBS in bytes. These values must be configured so that at least one of them is larger than zero. It is recommended that when the value of the CBS or EBS is larger than zero, it is larger than, or equal to, the size of the largest possible IP packet in the stream.

### Two-Rate TCM Parameters

#### Committed information rate (CIR)

Specifies the committed information rate.

#### Committed burst size (CBS)

Specifies the committed burst size.

#### Peak information rate (PIR)

Specifies the peak information rate.

#### Peak burst size (PBS)

Specifies the peak burst size.

#### Notes:

1. Specify the CIR and the PIR in bytes of IP packets per second. This includes the IP header, but not the link-specific header. The PIR value must be equal to or greater than the CIR.
2. Specify the CBS and PBS in bytes. Both must be configured to values larger than zero and larger than, or equal to, the size of the largest possible IP packet in the stream.

## Policy Configuration Commands (Talk 6)

### Expedited Forwarding

#### transmitted ds-byte mask

The mask to apply to transmitted ds bytes for expedited forwarding. This value designates which bits of a packet's DS byte must be changed when the packet is transmitted. A zero in any bit position of this byte implies that the bit must not change.

**Default value:** 00 (do not change any bits)

#### transmitted ds-byte modify value

The marking of the IP DS (TOS) byte for expedited forwarding that should be applied to packets to be forwarded by this device. Zeros in the mask imply that the corresponding bit will not change. A one implies that the bit will be marked with the bit value in the mark byte. The operation is:  
$$\text{newTOSByte} = (\text{Mask} \wedge \text{receivedTOSByte}) \vee (\text{Mask} \& \text{Mark})$$
  
The  $\wedge$  is a bit-based complement (Mask:Mark)

Example:

```
11111101:00000001
```

Using this example, a received value 0x07 would be sent with a value of 0x03

**Default value:** X'00' (do not change any bit)

#### EF policing type

Specifies the expedited forwarding police configuration type.

##### 1 Default config

The token rate and token bucket size parameters will be calculated from the bandwidth parameter configuration.

##### 2 Custom config

###### Token Rate:

The token replenishment rate.

###### Token Bucket Size:

The token bucket size.

#### Notes:

1. Specify the token rate in bytes of IP packets per second. This includes the IP header, but not the link-specific headers.
2. Specify the token bucket size in bytes. The value must be greater than zero, and greater than or equal to the size of the largest IP packet in the stream.

#### interface-pair

The interface pair associates a profile with a specific interface or set of interfaces. By default, the profile object does not restrict the policy from being applied to any one interface. If that is necessary, you may add interface pairs to accomplish it. The interface pair specifies the IP address of the interface on which the traffic is to arrive and the IP address of the interface on which the traffic is to leave.

The following example shows two interface pairs with the same name, representing traffic coming in on any interface and going out on the public interface, and conversely.

## Policy Configuration Commands (Talk 6)

```
1) Group Name: inOutPublic
   In:Out=255.255.255.255 : 1.1.1.1
   In:Out=1.1.1.1 : 255.255.255.255
```

**Name** The name of the interface pair.

### Ingress interface

IPv4 address of the input interface.

**Default value:** 255.255.255.255 (any)

### Egress interface

IPv4 address of the output interface.

**Default value:** 255.255.255.255 (any)

## IPSec-action

Prompts you for information for setting up the Phase 2 tunnel.

**Name** The name of the IPSec action.

### Action type

The action to apply to packets matching the profile of a policy containing this action.

- 1 Block (block connection).
- 2 Permit (Permit packets matching this action.) If an IPSec proposal does not exist, pass the packet; if an IPSec proposal exists, apply IPSec security processing to the packet.

**Default value:** 2

The following option is only available if you specify pass as the action type:

### Traffic flow type

Type of traffic flow (secure tunnel or in the clear).

- 1 Clear
- 2 Secure Tunnel

**Default value:** 2

The following option is only available if you specify the traffic flow as secure:

### Tunnel start point

IPv4 address of the tunnel start point.

### Tunnel end point

IPv4 address of the tunnel end point. (0.0.0.0 for remote access)

**Default value:** 0.0.0.0

### Tunnel-in-tunnel

Specifies whether the traffic being protected by this tunnel is to be further protected by another policy configured on this device.

**Valid options:** Yes or No

**Default value:** No

## Policy Configuration Commands (Talk 6)

### Percentage of SA lifiesize/lifetime to accept

The minimum SA lifiesize/lifetime (as a percentage) of the SA lifiesize/lifetime. An SA lifiesize/lifetime received with a value less than this is not accepted.

**Default value:** 75

### SA refresh threshold

The percentage into the SA lifetime or lifiesize value that the SA is to be refreshed automatically.

**Default value:** 85

### DF-Bit-Setting

Specifies whether to copy the Don't Fragment bit from the original packet, and whether to set or clear it in the outer header of the IPSec packet if running in tunnel mode.

- 1 Copy
- 2 Set
- 3 Clear

**Default value:** 1

### Replay-Prevention

Specifies whether IPSec is to enforce replay prevention for received IPSec packets. In this mode IPSec ensures that the sequence numbers are valid and not received more than once.

- 1 Enable
- 2 Disable

**Default value:** 2

### Negotiate SA Automatically

Specifies whether the Phase 2 SA is negotiated automatically at system initialization.

**Yes or No**

**Default value:** No

### IPSec proposal

The name of the IPSec proposal (you may specify up to five proposals) to be sent or checked during Phase 2. The order in which you specify them determines their priority, with the first one being the highest.

### IPSec-manual-tunn

Prompts you for information for manually setting up the Phase 2 tunnel.

#### Tunnel name

The name of the IPSec manual tunnel.

#### Tunnel lifetime

The tunnel lifetime (in minutes).

**Default value:** 46080

#### Encapsulation mode

The encapsulation mode to use.

## Policy Configuration Commands (Talk 6)

**tunn** Tunnel mode

**trans** Transport mode

**Default value:** tunn

**Policy** The type of tunnel policy to use.

**AH** Authentication Header

**ESP** Encapsulating Security Payload

**AH-ESP**

For outbound packets, specifies that encryption runs before authentication.

**ESP-AH**

For outbound packets, specifies that authentication runs before encryption.

**Default value:** AH-ESP

**Local IP address**

The source IPv4 address.

**Default value:** 11.0.0.5

**Local encryption SPI**

The source security parameters index value.

**Default value:** 256

**Local encryption algorithm**

The source encryption algorithm.

**Null** No encryption.

**CDMF** Commercial Data Masking Facility.

**DES-CBC**

Data Encryption Standard and Cipher Block Chaining.

**3DES** Triple Data Encryption Standard.

**Default value:** DES-CBC

**Local encryption key**

A 16-character key.

**Padding**

Additional padding for local encryption.

**Default value:** 0

**Local ESP authentication**

Specifies whether local ESP authentication is to be used.

**Yes or No**

**Default value:** Yes

**Remote IP address**

The destination IPv4 address.

**Default value:** 0.0.0.0

## Policy Configuration Commands (Talk 6)

### Remote encryption SPI

The destination security parameters index value.

**Default value:** 256

### Remote encryption algorithm

The destination encryption algorithm.

**Null** No encryption.

**CDMF** Commercial Data Masking Facility.

#### DES-CBC

Data Encryption Standard and Cipher Block Chaining.

**3DES** Triple Data Encryption Standard.

**Default value:** DES-CBC

### Remote encryption key

A 16-character key.

### Verify remote encryption padding.

Specifies whether to verify remote encryption padding.

**Yes or No**

**Default value:** No

### Remote ESP authentication

Specifies whether remote ESP authentication is to be used.

**Yes or No**

**Default value:** Yes

**DF bit** Specifies how to process the Don't Fragment bit.

**Copy** Copies the DF bit.

**Set** Sets the DF bit on.

**Clear** Sets the DF bit off.

**Default value:** COPY

### Enable tunnel

Specifies whether to enable the tunnel when it is created.

**Yes or No**

**Default value:** Yes

### IPSec-proposal

Prompts you for information for creating an IPSec proposal.

#### IPSec proposal name

The name of the IPSec proposal.

#### Perfect forward secrecy

Specifies whether IKE is to be used, to prevent anyone from determining a current key from a previously compromised key.

**Yes or No**

**Default value:** No

## Policy Configuration Commands (Talk 6)

### Diffie Hellman Group ID

The type of Diffie Hellman group.

- 1 Diffie Hellman Group 1
- 2 Diffie Hellman Group 2

**Default value:** 1

### AH transform

The name of the AH transform (you may specify up to five transforms) for this proposal. The order in which you specify them determines their priority, with the first one being the highest.

### ESP transform

The name of the ESP transform (you may specify up to five proposals) for this proposal. The order in which you specify them determines their priority, with the first one being the highest.

### IPSec-transform

Prompts you for information about IPSec transforms.

#### IPSec transform name

The name of the IPSec transform.

#### Protocol ID

The security protocol to use.

- 1 IPSec-AH
- 2 IPSec-ESP

**Default value:** 1

#### AH Authentication Algorithm

The AH authentication algorithm to use.

- 1 HMAC-MD5
- 2 HMAC-SHA

**Default value:** 1

#### Encapsulation mode

The encapsulation mode to use.

- 1 Tunnel
- 2 Transport

**Default value:** 1

#### ESP Authentication Algorithm

The ESP authentication algorithm to use.

- 0 None
- 1 HMAC-MD5
- 2 HMAC-SHA

**Default value:** 2

#### ESP cipher algorithm

The ESP cipher algorithm to use.

## Policy Configuration Commands (Talk 6)

- 1 ESP DES
- 2 ESP 3DES
- 3 ESP CDMF
- 4 ESP Null (no encryption)

**Default value:** 1

### SA lifesize

The lifesize (in kb) of the SA for this proposal.

**Default value:** 50000

### SA lifetime

The lifetime (in seconds) of the SA for this proposal.

**Default value:** 3600

## ISAKMP-Action

Prompts you for information about which ISAKMP action to apply.

**Name** The name of the ISAKMP action.

### Exchange mode

The type of exchange mode for Phase 1 negotiations.

- 1 Main
- 2 Aggressive

**Default value:** 1

### Percentage of Minimum SA lifesize/lifetime

The minimum SA lifesize/lifetime (as a percentage) of the SA lifesize/lifetime. An SA lifesize/lifetime with a value less than this is not accepted.

**Default value:** 75

### ISAKMP connection lifesize

The lifesize (in kb) of the Phase 1 connection. Once the Phase 1 connection expires, the next time the Phase 2 SA must refresh, Phase 1 completely renegotiates before Phase 2 can start.

**Default value:** 5000

### ISAKMP connection lifetime

The lifetime (in seconds) of the Phase 1 connection. Once the Phase 1 connection expires, the next time Phase 2 must refresh, Phase 1 starts over completely.

**Default value:** 5000

### Negotiate SA automatically

Specifies whether the SA is negotiated automatically at system initialization.

**Yes or No**

**Default value:** No

### ISAKMP proposal

The name of the ISAKMP proposal (you may specify up to five



## Policy Configuration Commands (Talk 6)

proposals) to be sent or checked during Phase 2 quick mode. The order in which you specify them determines their priority, with the first one being the highest.

### ISAKMP-Proposal

Prompts you for the ISAKMP proposal information used in the ISAKMP negotiations.

#### ISAKMP proposal name

The name of the ISAKMP proposal.

#### Authentication method

The type of authentication to use during ISAKMP Phase 1 negotiations.

- 1 Pre-Shared Key
- 2 RSA SIG (certificate mode)

**Default value:** 1

#### Hash algorithm

The type of hash algorithm to use during Phase 1 negotiations.

- 1 MD5
- 2 SHA

**Default value:** 1

#### Cipher algorithm

The type of cipher algorithm to use during Phase 1 negotiations.

- 1 DES
- 2 3DES

**Default value:** 1

#### Diffie Hellman Group ID

The type of Diffie Hellman group to use during Phase 1 negotiations.

- 1 Diffie Hellman Group 1
- 2 Diffie Hellman Group 2

**Default value:** 1

#### SA lifiesize

The lifiesize (in kb) of the SA for this proposal.

**Default value:** 50000

#### SA lifetime

The lifetime (in seconds) of the SA for this proposal.

**Default value:** 5000

**Policy** Prompts you for information about the policy configuration: Profile name (required), RSVP name (optional), DiffServ name (optional), IPSec name (optional), ISAKMP name (optional), and Validity Period Profile (optional). You must specify either DiffServ, IPSec, ISAKMP, or RSVP for the policy to be valid.

**Default value:** Valid all the time

## Policy Configuration Commands (Talk 6)

**Name** The name of the policy configuration

**Priority**

Relative priority of this policy to other policies (the higher the number, the higher the priority). This is used to resolve conflicts if multiple policies apply to a packet.

**Default value:** 5

**Profile**

The name of a previously configured data traffic profile to use for this policy.

**Validity period**

The name of a previously configured validity period to use for this policy.

**IPSec action**

If this policy will enforce an IPSec action, the name of a previously configured IPSec action to use for this policy. If you specify a secure IPSec action, you must also specify an ISAKMP action.

**ISAKMP action**

The name of a previously configured ISAKMP action to use for this policy. If you specify an ISAKMP action, you must also specify an IPSec action.

**Diffserv action**

If you want to map a DiffServ action to this policy, the name of a previously configured DiffServ action.

**RSVP action**

The name of an RSVP action for this policy to enforce.

**Profile**

Prompts you for information for defining a set of selectors (conditionals) for a policy profile on which to perform actions.

**name** The name of the policy profile.

**ipv4-src-address-format**

The format of the IPv4 source address (range, netmask, single address).

**ipv4-src-address**

The IPv4 source address (low address if address format is *range*).

**Default value:** 0.0.0.0

**ipv4-src-mask**

The IPv4 source mask (high address if address format is *range*).

**Default value:** 255.0.0.0

**ipv4-dest-address-format**

The format of the IPv4 destination address (range, netmask, single address).

**ipv4-dest-address**

The IPv4 destination address (low address if address format is *range*).

**Default value:** 0.0.0.0

## Policy Configuration Commands (Talk 6)

### ipv4-dest-mask

The IPv4 destination mask (high address if address format is *range*).

**Default value:** 255.0.0.0

### protocol-id

The protocol ID on which to filter.

- 1 TCP
- 2 UDP
- 3 All protocols
- 4 Specify range

**Default value:** 3

### src-port-start

The first port number of the source port number range.

**Default value:** 0

### src-port-end

The last port number of the source port number range.

**Default value:** 65535

### dest-port-start

The first port number of the destination port number range.

**Default value:** 0

### dest-port-end

The last port number of the destination port number range.

**Default value:** 65535

### src-id-type

The source ID type, which is sent to the remote. This value is used to determine which policy contains the ISAKMP information needed during ISAKMP Phase 1 negotiations. It is compared to the information in the identification payload of the ISAKMP packet. This information is needed if the remote peer must identify the device with a value other than IP address.

- 1 Local tunnel end point
- 2 Host fully qualified domain name
- 3 User fully qualified domain name
- 4 Key ID

### any-user-access

Allow access for any user within the profile definition. If you specify No, then you are prompted for the name of the remote user group for this profile. This attribute is only required if you want to limit the access of remote access peers to a specific policy.

**Yes or No**

**Default value:** Yes

### Received DS byte mask

The 8-bit mask to apply to an incoming packet's DS (TOS) byte.

## Policy Configuration Commands (Talk 6)

**Default value:** 0

### Received DS byte match

The 8-bit pattern to compare to the result of ANDing the incoming DS (TOS) byte with the Received DS byte mask value.

**Default value:** 0

### Interface pairs

If this policy must restrict the traffic flows to specific interfaces, this is the name of the interface pair group.

## RSVP-Action

Prompts you for information about which RSVP actions apply.

**Name** The name of the RSVP action.

### Permission

Specifies the permission level for RSVP sessions that match this action.

1 Permit

2 Deny

**Default value:** 2

### Max token rate

The maximum amount of bandwidth (in kbps) that RSVP is to allocate for an individual flow.

**Default value:** 100

### Max duration

The maximum amount of time (in seconds) that a flow can last (0 implies forever).

**Default value:** 600

### RSVP-to-DS

Specifies whether to map RSVP flows that match this action to a configured DiffServ action. RSVP uses the information from the DiffServ action to mark the TOS byte for the next DiffServ-enabled upstream device. This is for use in a network in which packets leave an RSVP-enabled network into a DiffServ-enabled network.

**Yes or No**

**Default value:** No

**User** Prompts you for information about the user profile definition for the remote IKE peer. This information includes how the peer must identify itself during phase 1 negotiations, the authentication method to use for this peer, and, if the authentication mechanism is pre-shared key, the key value to use. If you use pre-shared key, you **must** define a user in order to associate the pre-shared key with an ID type and name. This command sets the key that is used in phase 1 negotiation for a particular user. The key is used in messages 1 and 5 for initiators and messages 2 and 6 for responders.

### Identification

Identification of the user. For main mode authentication, the user identification type **must** be IP address. For aggressive mode authentication, the identification type should be one of the other types. The reason for this is that in main mode the IDs are not

## Policy Configuration Commands (Talk 6)

exchanged until messages 5 and 6, which is too late for the pre-shared key, thus the only look-up mechanism is through the IP address of the IKE peer. In aggressive mode, the IDs are exchanged in messages 1 and 2, thus the pre-shared key lookup can be done through the ID type and corresponding value.

- 1 IP address.
- 2 Fully qualified domain name.
- 3 User fully qualified domain name.
- 4 Key ID (any string).

**Default value:** 1

**Group** Name of group in which to place this user.

**Default value:** none

### Authentication

Authentication method to use with peer.

- 1 Pre-shared key.
  - 1 Key in ASCII format.

**Valid values:** An even number of 2 to 128 characters
  - 2 Key in hexadecimal format.

**Valid values:** An even number of 2 to 256 hexadecimal digits
- 2 Public certificate.

**Default value:** 1

### VALIDITY-PERIOD

Prompts you for information about the period during which the policy is valid, and creates a policy profile.

**Name** The name of the validity period profile.

#### yyyymmddhhmmss:yyyymmddhhmmss

The period during which the policies containing this validity period profile are valid.

#### Example:

```
19980101000000:19981231000000
```

### Months

The months during which the policies containing this validity period profile are valid. You can specify any sequence of months, using the first three letters of each month (for example, jan or dec), with the months separated by a spaces, or you can specify all to signify every month of the year.

**Days** The dates on which the policies containing this validity period profile are valid. You can specify any sequence of dates, using the first three letters of each day (for example, mon or fri), with the days separated by a spaces, or you can enter all to specify every day of the week.

## Policy Configuration Commands (Talk 6)

### Starting time

The time at which policies containing this validity period profile are valid. Specify this in the form hh:mm:ss or specify \* if you want the policy to be valid all day.

**Default value:** \*

### Ending time

The time at which the validity of policies containing this validity period profile expires. Specify this in the form hh:mm:ss.

**Default value:** None

## Change

Use the **change** command to change information in a policy object. See the description of the **add** command for the available objects.

## Copy

Use the **copy** command to copy information from one policy object to another. See the description of the **add** command for the available objects. (The interface-pair, manual tunnel, and user options do not apply to the **copy** command.)

## Delete

Use the **delete** command to delete information from a policy object. See the description of the **add** command for the available objects.

## Disable

Use the **disable** command to disable a policy configuration.

**Syntax:** disable policy

**Policy** Prompts you for the name of the policy configuration to disable.

## Enable

Use the **enable** command to enable a policy configuration.

**Syntax:** enable policy

**Policy** Prompts you for the name of the policy configuration to enable.

## List

Use the **list** command to display any or all of the policy configuration information.

**Syntax:** list all  
default-policy  
ldap  
refresh

**All** Displays all policy configuration information.

### Default-policy

Displays the name of the default policy.

**LDAP** Displays the names of the defined LDAP configurations.

### Refresh

Lists the policy refresh status (Enable or Disable) and the refresh interval time.

## Qconfig

Use the **qconfig** command to quickly create security policies for a network device. Once you select a configuration scenario from a short list, the command displays a brief series of simple questions based on your selection. It then creates an entire policy using predefined scenario-related templates (whole sets of compatible policy options). This eliminates the need for you to specify every detail of the policy, reducing the time required to configure a policy and the chance of making a mistake.

This command prompts you to specify a security level for all scenarios except the Custom scenario.

**Syntax:** `qconfig` *policy-name*  
*scenario*

### **policy-name**

Specifies a name (maximum of 29 characters) to assign to the policy.

**Default value:** A system-generated unique name.

### **scenario**

Specifies the scenario for which to create a policy.

**Default value:** none

#### **1 Branch office scenario.**

This selection enables you to specify the policy options for a secured connection between two Security Gateways protecting local subnets.

The options are:

**Local IP Subnet**

**Local IP Tunnel Endpoint**

**Remote IP Subnet**

**Remote IP Tunnel Endpoint**

**Ports and Protocols**

**Security Level**

**1:** Strong Security. Select this option if you want security, performance, and flexibility. It negotiates a suite of proposals (without PFS) that includes combinations of SHA and MD5 authentication algorithms and DES and 3DES encryption algorithms. The strong proposals are negotiated first, followed by the stronger proposals, so as not to compromise performance.

**2:** Very Strong Security. Select this option if you require the highest level of security. It negotiates a small suite of proposals (with PFS, Grp 1) that includes combinations of SHA and MD5 authentication algorithms and 3DES encryption algorithms.

**Authentication Method**

1: Pre-shared Key - ASCII key

2: Certificate (RSA Signatures) - local ID

## Policy Configuration Commands (Talk 6)

### DiffServe Actions

- 0:Best Effort (No DiffServ)
- 1:EF
- 2:AF11
- 3:AF21
- 4:AF31
- 5:AF41

Any other locally-configured DiffServ actions also appear in this list.

### Validity Periods

- 1. 1: allTheTime
- 2. 2: allTheTimeMonThruFri
- 3. 3: 9to5MonThruFri
- 4. 4: 5to9MonThruFri

Any other locally-configured validity periods also appear in this list.

### Priority of Policy

## 2 Remote access user scenario (IPSec and L2TP).

This selection enables you to specify the policy options for a secured connection between a Security Gateway and remote access users. This scenario assumes that the remote access client has the capability of running L2TP on top of IPSec in transport mode.

L2TP sets up a point-to-point connection between the remote access client's public IP address and the security gateway's public IP address. UDP provides the transport layer connection, and the source and destination ports are 1701. It is important that L2TP be configured for fixed-udp-source-port on the router performing the security gateway function. IPSec provides the protection for the L2TP connection on these ports and protocols.

Once the configuration scenario has been completed, you must add users in the policy feature for anyone who will be authenticated using pre-shared key. For certificate authentication, you must configure the PKI parameters on the router and ensure that the appropriate certificates are loaded.

The options are:

### IP address of secure interface.

Typically, this is the same value as the local IP tunnel endpoint. It represents the IP address of the interface on which packets are sent out secured and arrive secured.

### Security Level

- 1: Strong Security
- 2: Very Strong Security

### DiffServe Actions

- 0:Best Effort (No DiffServ)
- 1:EF
- 2:AF11
- 3:AF21
- 4:AF31



5:AF41

Any other locally-configured DiffServ actions also appear in this list.

### Validity Periods

1. 1: allTheTime
2. 2: allTheTimeMonThruFri
3. 3: 9to5MonThruFri
4. 4: 5to9MonThruFri

Any other locally-configured validity periods also appear in this list.

### Priority of Policy

- 3 Drop traffic not matched on untrusted interface. This scenario is needed for configurations in which the device is acting as a firewall. In many network configurations a firewall is in front of the security gateway and a drop rule is not needed. If you need a drop rule, then select this scenario.

The options are:

#### IP address of untrusted interface.

This is the IP address of the interface for which undesirable packets are dropped. Typically, it is the IP address of the connection to the public or untrusted network.

- 4 **Custom scenario.**

This selection provides the most flexibility in using **qconfig** to define a policy. You are prompted to select an encapsulation mode (either Tunnel or Transport). If you choose tunnel mode, you are presented with the same questions as in the Branch Office scenario. If you choose transport mode, you are presented with the Branch Office scenario questions except for those dealing with the local and remote subnets, because they are not applicable.

---

## LDAP Policy Server Configuration Commands

The LDAP policy server configuration commands enable you to specify LDAP server options for retrieving policy information. Table 39 summarizes the LDAP configuration commands, and the rest of this section describes them in detail. Enter them at the `Policy config>` prompt. You can either enter the command and options on one line, or enter only the command and respond to the prompts. To see a list of valid command options, enter the command with a question mark instead of options.

Table 39. LDAP Configuration Commands

Command	Function
? (Help)	Displays all the commands available for this command level or lists the options for specific commands (if available). See “Getting Help” on page xxxii.
Disable ldap	Disables LDAP configuration options.
Enable ldap	Enables LDAP configuration options.
Set ldap	Specifies LDAP configuration options.
Exit	Returns you to the previous command level. See “Exiting a Lower Level Environment” on page xxxii.

## LDAP Configuration Commands (Talk 6)

### Disable LDAP

Use the **disable ldap** command to disable LDAP policy search functions in the directory or from reading cached policies from the LDAP server into persistent storage.

**Syntax:** disable ldap                    \_cached-search  
  \_policy-search

#### **cached-search**

Disables LDAP from reading cached policies from the server into persistent storage.

#### **policy-search**

Disables LDAP from performing policy search functions in the directory.

### Enable LDAP

Use the **enable ldap** command to enable LDAP policy search functions in the directory or for reading cached policies from the LDAP server into persistent storage.

**Syntax:** enable ldap                    \_cached-search  
  \_policy-search

#### **cached-search**

Enables LDAP for performing policy search functions in the directory or for reading cached policies from the LDAP server into persistent storage.

If you enable this option when the policy-search option is disabled, then the policy search engine only reads policies from the local cache. If you enable both the cached-search option and the policy-search option, then the policy search engine tries to read from the LDAP server first and if it is unsuccessful it reads from the cached LDAP policy objects. See the **cache-ldap-polcys** command at “Policy Monitoring Commands” on page 332 for an explanation of how to cache the LDAP policies.

#### **policy-search**

Enables LDAP for performing policy search functions in the directory.

### Set Default-Policy

Use the **set default-policy** command to specify the policy options to use while the policy database is being refreshed. The command sets the error handling options and the default security needed for accessing the LDAP policy server.

**Syntax:** set                                    \_default-policy  
  default-error-handling  
  default-security

#### **default-error-handling**

Specifies the error handling options to use while the policy database is being refreshed.

**Note:** The default error handling setting determines the behavior of the device if an error occurs while rebuilding the policy database. If an error occurs then you have the options for how the device is to behave. They are:

1. Reset policy database to default security.

## LDAP Configuration Commands (Talk 6)

2. Flush any rules read from LDAP, load local rules plus default security.

These settings are only valid if there was an error building the policy database. Either option inherits the default security of drop or pass when an error occurs. If you select option 2 then all traffic is dropped or passed unless it matches a locally defined policy. If the policy database builds successfully then this option is not used.

### default-security

Specifies the security options to use while the policy database is being refreshed.

**Note:** Once the policy database has been built successfully, the default behavior is defined as pass. This means that if a packet does not match any policy rule then it will be passed in the clear. If you want packets that do not match a rule to be dropped globally or just for certain interfaces, then you must define a policy to do that.

1 Accept and forward all IP traffic.

2 Permit LDAP traffic, drop all other IP traffic.

If you select this option, then you are prompted for the local IP addresses on the device on which the LDAP traffic is to be sent and received.

3 Permit and secure LDAP traffic, drop all other IP traffic.

If you select this option, then you are prompted for the following information:

#### DHGroupId

The Diffie-Hellman Group Id to use during the ISAKMP Phase 1 negotiations.

1 DH Group 1.

2 DH Group 2.

#### Phase1-Hash-Algorithm

The hash algorithm to use during the Phase 1 negotiations. The hash algorithm provides the authentication of the Phase 1 messages.

1 MD5.

2 SHA.

#### Phase1-Cipher-Algorithm

The cipher algorithm to use during Phase 1 negotiations. The cipher algorithm provides encryption protection for the Phase 1 negotiations.

1 DES

2 3DES

#### Phase1-Authentication-Method

The authentication method to use with the remote peer. This specifies how ISAKMP determines whether the remote peer is actually the correct device with which to be negotiating.

1 Pre-shared key

## LDAP Configuration Commands (Talk 6)

2 Certificate (RSA SIG)

### Pre-Shared-Key-Value

If you have specified the pre-shared key Phase 1 authentication method, then you are prompted to enter the key value in ASCII.

### Phase2-ESP-Authentication-Algorithm

ESP is the only IPsec protocol allowed for the default security. You are prompted for the authentication algorithm to use during Phase 2 ISAKMP negotiations.

0 None  
1 HMAC-MD5  
2 HMAC-SHA

### Phase2-ESP-Cipher-Algorithm

ESP is the only IPsec protocol allowed for the default security. You are prompted for the encryption algorithm to use during Phase 2 ISAKMP negotiations.

1 ESP DES  
2 ESP 3DES  
3 ESP CDMF  
4 ESP NULL

### Primary-Tunnel-Start

The IP address on the device that is to be used for the IKE and IPsec traffic between the device and the security gateway protecting the primary LDAP server.

### Primary-Tunnel-End

The IP address on the remote security gateway protecting the primary LDAP server that are to be used for the IKE and IPsec traffic.

### Secondary-Tunnel-Start

The IP address on the device that is to be used for the IKE and IPsec traffic between the device and the security gateway protecting the secondary LDAP server.

### Secondary-Tunnel-End

The IP address on the remote security gateway protecting the secondary LDAP server that are to be used for the IKE and IPsec traffic.

## Set LDAP

Use the **set ldap** command to configure the LDAP operating parameters.

```
Syntax: set ldap          _anonymous-bind
                        yes
                        no
                        _bind-name <name>
                        _bind-pw <pw>
                        _policy-base <string>
```

## LDAP Configuration Commands (Talk 6)

primary <*ip-address*>

secondary <*ip-address*>

version <*value*>

### **anonymous-bind [Yes or No]**

Specifies whether you want to bind to the LDAP directory anonymously or with the bind name and bind password you have specified.

**Default value:** Yes

### **bind-name <name>**

Prompts you for information needed to bind to the LDAP server before a search of its directory can be performed. The *name* parameter specifies the distinguished name that the router uses to identify itself. If you do not enter this parameter, then the bind is issued as an anonymous request.

### **bind-pw <pw>**

Prompts you for information needed to bind to the LDAP server before a search of its directory can be performed. The *pw* parameter is the password related to the distinguished name. If you do not enter this parameter, then the bind is issued as an anonymous request.

### **policy-base <string>**

Prompts you to enter a character string that is used to define the scope of the search for policies in the router's SRAM and the LDAP server. For example, you can use this option to return policies that only apply to router A, or for NHD, or for IBM-US. The policy-base is the distinguished name of the DeviceProfile object in the LDAP server.

### **primary <ip-address>**

Prompts you for the IPv4 address of the LDAP server from which to retrieve policies.

### **secondary <ip-address>**

Prompts you for the IPv4 address of a backup LDAP server that is used if the default server cannot be reached.

### **version <value>**

Prompts you for the LDAP version number supported by the LDAP server.

**Default value:** 2 (The only acceptable values are 2 or 3.)

## Set Refresh

Use the **set refresh** command to enable or disable automatic refresh of the policy database once each day. If enabled then the policy database automatically refreshes once a day at the specified time. This enables all policy-enabled routers in the network to incorporate automatically any policy changes that have occurred in the LDAP directory. To reset this parameter, use the policy feature's Talk 5 **reset refresh** command.

**Syntax:** set refresh

enabled

yes

no

<*time*>

### **enabled [yes or no]**

Specifies whether to perform the automatic refresh.

## LDAP Configuration Commands (Talk 6)

<time>

If you specify enabled yes, designates the time of day (in 24-hour format) at which the refresh is to occur.

---

## Accessing the Policy Monitoring Prompt

The policy console portion of the policy feature enables you to view policies that are in the policy database and to enable or disable individual policies. To access the Policy monitoring environment type **talk 5** at the OPCON prompt (\*):

```
* t 5
```

Then, enter the following command at the **+** prompt:

```
+ feature policy  
Policy>
```

---

## Policy Monitoring Commands

These commands enable you to view the profiles defined in the policy database and to enable or disable individual policies. Table 40 summarizes the policy monitoring commands and the rest of this section describes them. Enter the commands at the `Policy console>` prompt. You can either enter the command and options on one line, or enter only the command and respond to the prompts. To see a list of valid command options, enter the command with a question mark instead of options.

Table 40. Policy Monitoring Commands

Command	Function
? (Help)	Displays all the commands available for this command level or lists the options for specific commands (if available). See "Getting Help" on page xxxii.
Cache-ldap-plcys	Stores a copy of the most recent policy information read from the LDAP server into the router's persistent configuration storage.
Check-consistency	Checks for consistency within individual policies and between all configured policies.
Disable	Disables a policy that is loaded in the policy database.
Enable	Enables a policy that is loaded in the policy database.
Flush-cache	Clears the cached policy information out of the router's persistent configuration storage.
Reset	Refreshes or resets policy-related criteria.
Search	Tests or debugs activity between the LDAP client and server.
Status	Displays information about the policy database.
List	Displays information about the LDAP configuration and the policies defined.
Test	Queries the policy engine and retrieves the rules that were selected
Exit	Returns you to the previous command level. See "Exiting a Lower Level Environment" on page xxxii.

### Cache-LDAP-Plcys

Use the **cache-ldap-plcys** command to store a copy of the most recent policy information read from the LDAP server into the router's persistent configuration storage. This removes any existing cached policy information from persistent storage.

**Syntax:** `_cache-policy`

**Note:** On 2212 and 2216 platforms, entering this command also writes the entire router configuration, as the Talk 6 **write** command does.

### Check-Consistency

Use the **check-consistency** command to check for potential inconsistencies between the options configured in an individual policy (internal), and between policies with overlapping definitions (external). You may then take corrective action to resolve any conflicts.

An *internal* inconsistency is one that exists between action objects within a single policy, for example, a policy with a DiffServ action type of Deny also has an IPSec action type of Permit. An *external* inconsistency is one that exists between separate policies that have overlapping profiles, for example, one policy has a DiffServ action type of Block, and another policy has an IPSec action type of Permit. Another example is if overlapping policies specify different IPSec action types.

**Syntax:** `_check-consistency`

#### Example:

Assume that policies have been configured as follows:

```
Policy Name: dsDown
Loaded from: Local
State: Enabled and Valid
Priority: 5
Hits: 0
Profile: DSUP
Validity: always
DiffServ: dsDown
RSVP: rsvpActUp
Policy Name: ManualTunnel
Loaded from: Local
State: Enabled and Valid
Priority: 5
Hits: 0
Profile: DSUP
Validity: always
Tunnel ID: 1
Policy Name: ike
Loaded from: Local
State: Enabled and Valid
Priority: 30
Hits: 0
Profile: DSUP
Validity: always
IPSec: ipsecUP
ISAKMP: generalPhase1Action
```

## Policy Monitoring Commands (Talk 5)

The **consistency-check** command output would appear as follows:

```
Policy console>check-consistency
Checking for inconsistencies with a policy...
Rule dsDown contains two conflicting actions:
  RSVP Action is of type PERMIT
  DiffServ Action is of type BLOCK

Checking for inconsistencies among policies with overlapping profiles...
Mismatching IPsec and DiffServ actions at Priority 181 between:
  Rule: ike.traffic      State: ENABLE  Prio: 5 IPsec Action: PERMIT
  Rule: dsDown          State: ENABLE  Prio: 5 DiffServ Action: BLOCK

Two rules with IPsec actions:
  Rule: ike.traffic      State: ENABLE  Prio: 30 Action: PERMIT
  Rule: Man              State: ENABLE  Prio: 5 Action: PERMIT

Two rules with IPsec actions:
  Rule: ike.inBoundTunnel State: ENABLE  Prio: 30 Action: PERMIT
  Rule: Man.inBoundTunnel State: ENABLE  Prio: 5 Action: PERMIT

Two rules with IPsec actions:
  Rule: Man.inBoundTunnel State: ENABLE  Prio: 5 Action: PERMIT
  Rule: ike.inBoundTunnel State: ENABLE  Prio: 30 Action: PERMIT

Two rules with IPsec actions:
  Rule: Man              State: ENABLE  Prio: 5 Action: PERMIT
  Rule: ike.traffic      State: ENABLE  Prio: 30 Action: PERMIT

Mismatching IPsec and DiffServ actions at Priority 5 between:
  Rule: Man              State: ENABLE  Prio: 5 IPsec Action: PERMIT
  Rule: dsDown          State: ENABLE  Prio: 5 DiffServ Action: BLOCK

Mismatching IPsec and DiffServ actions at Priority 5 between:
  Rule: dsDown          State: ENABLE  Prio: 5 DiffServ Action: BLOCK
  Rule: ike.traffic      State: ENABLE  Prio: 30 IPsec Action: PERMIT

Mismatching IPsec and DiffServ actions at Priority 5 between:
  Rule: dsDown          State: ENABLE  Prio: 5 DiffServ Action: BLOCK
  Rule: Man              State: ENABLE  Prio: 5 IPsec Action: PERMIT
```

## Disable

Use the **disable** command to disable a policy that is currently loaded in the policy database. Any data packet that matches the criteria of a policy you disable will have default decisions applied to it.

**Syntax:** `disable` *policy-name*

## Enable

Use the **enable** command to enable a policy that is currently loaded in the policy database. Any data packet that matches the criteria of a policy you enable will have the decisions configured for the policy applied to it.

**Syntax:** `enable` *policy-name*

## Flush-Cache

Use the **flush-cache** command to clear the most recently cached copy of the policy information read from the LDAP server out of the router's persistent configuration storage.

**Syntax:** `flush-cache`

## Reset

Use the **reset** command to refresh or reset policy-related criteria.

**Syntax:** `reset` *ldap-config*



## Policy Monitoring Commands (Talk 5)

policy-database

refresh-time

### ldap-config

Dynamically loads the LDAP configuration (as specified in the **set ldap** command) into memory. Any changes become active for the next search operation. This command also forces a reset of the policy database and inactivates the policy database refresh time.

### policy-database

Refreshes the policy database. Stops all tunnels, Phase 1 and Phase 2 SAs, resets RSVP and DiffServ data structures, and flushes the policy database. Then policies are loaded from the LDAP server and an autostart is done. While the database is being rebuilt, no packets will be allowed in to or out of the router except for packets to and from the LDAP server.

### refresh-time

Sets the time at which the policy database will be refreshed automatically on a daily basis. If you have disabled the refresh time, then the database will not be refreshed until the router is rebooted or restarted.

## Search

Use the **search** command to test or debug activity between the LDAP client and server. You can perform searches against the directory and have the results of the searches displayed in talk 5.

**Syntax:** `search` *filter*  
*ipaddress*

*filter* Specifies a filter value for the search operation.

*ipaddress*  
Specifies the IP address of the server.

## Status

Use the **status** command to display information about the policy database.

**Syntax:** `status`

**status** Displays the results of the most recent policy database refresh, the time that has elapsed since the refresh, and the time that the next refresh is scheduled.

### Example:

```
Policy>status
Status of Last Search:      Failed
Time since last refresh:   4 seconds
Next Policy Refresh not scheduled
```

## List

Use the **list** command to display information about LDAP configurations and policies.

**Syntax:** `list` *default-policy*  
*ldap*  
*policy*

## Policy Monitoring Commands (Talk 5)

\_refresh

\_rule

\_stats

### **default-policy**

Lists the default policy used during policy database refreshes.

**ldap** Lists the LDAP configurations in SRAM.

### **policy**

**basic** Lists policy components by logical policy name. You may select one policy or list all policies. The listing displays the names of the components of policies as they were entered in during configuration in Talk 6.

#### **complete**

Does the same as list policy basic, except that the listing displays a complete listing of all parameter values for each logical policy.

#### **generated**

Does the same as list policy basic, except that the listing displays the names of all the generated rules for each logical policy.

### **refresh**

Lists the policy refresh status (Enable or Disable) and the refresh interval time.

**rule** Lists information about generated rules according to the following options:

**basic** Lists all the generated rules. You can select a rule from the list or list all rules. The listing displays the names of the components of the rules. The components are:

**policy name**

**loaded from (LDAP or local)**

**state**

**priority**

**number of hits**

**profile**

**validity (followed by an action list consisting of the following)**

IPSec (and, or)

ISAKMP (and, or)

DiffServ (and, or)

RSVP

#### **complete**

Does the same as rule basic, except that the listing displays the names of all the parameters for each component.

**stats** Lists the rules that have been hit and the number of hits. A rule can have multiple actions and not all actions are hit, so this options also indicates which action of the rule was hit, and the number of times.

## Test

Use the **test** command to verify the behavior of the policy database. It allows you to enter a selector set, which queries the policy engine and retrieves the rules that match. You are prompted for the source and destination addresses, source and destination ports, the protocol ID, and the TOS value. If a rule is matched, then the command returns the name of the rule. Otherwise it indicates *No match found*.

**Syntax:** `test` forwarder  
ISAKMP

## Policy Monitoring Commands (Talk 5)

IPSec

RSVP

### **forwarder**

Simulates a database query from the IP forwarding engine and returns any policy decisions that would result from such a query. The type of policy returned could include DiffServ information, IKE Phase 1 and Phase 1 information, and IPSec manual tunnel IDs.

### **ISAKMP**

Simulates a database query from IKE for Phase 1 policy information and returns any policy decisions that would result from such a query. If you use this option, you must set the source and destination addresses to the tunnel endpoint IP addresses, the protocol to 17, and the source and destination ports to 500.

**IPSec** Simulates a database query from IKE for Phase 2 policy information and returns any policy decisions that would result from such a query. If you use this option, you must set the source and destination addresses to the tunnel endpoint IP addresses, the protocol to 17, and the source and destination ports to 500.

**RSVP** Simulates a database query from RSVP and returns any RSVP policy decisions that would result from such a query.

---

## Policy Dynamic Reconfiguration Support

This section describes dynamic reconfiguration (DR) as it affects Talk 6 and Talk 5 commands.

### **CONFIG (Talk 6) Delete Interface**

The policy feature does not support the CONFIG (Talk 6) **delete interface** command.

### **GWCON (Talk 5) Activate Interface**

The GWCON (Talk 5) **activate interface** command is not applicable for the policy feature. The configuration for the policy feature determines the set of rules and subsequent actions that should be applied to IP traffic, which is independent of a particular interface.

### **GWCON (Talk 5) Reset Interface**

The GWCON (Talk 5) **reset interface** command is not applicable for the policy feature. The configuration for the policy feature determines the set of rules and subsequent actions that should be applied to IP traffic, which is independent of a particular interface.

## GWCON (Talk 5) Component Reset Commands

Policy Feature supports the following Policy Feature-specific GWCON (Talk 5) **reset** commands:

### **GWCON, Feature Policy, Reset, Database Command**

#### **Description:**

All policies configured in the feature policy will be read from local configuration. If LDAP searching has been enabled, policies for this device will be read from the LDAP server. Any other changes to underlying policy

## Policy Monitoring Commands (Talk 5)

objects such as DIFFSERV Actions, IPSec and IKE policy objects that are used by policies will be re-loaded from configuration as well.

Once all the policies have been read, the policy database will be built from the collection of rules that are generated from these policies. During the period while the policies are being read, a default database is created with the default rule configured in Talk 6, using the **feature policy, set default-policy** command.

### Network Effect:

During the period while the policy database is being built, IPv4 unicast traffic will be forwarded based on the default policy configured in Talk 6. The default policy either passes all traffic, drops all traffic except for LDAP traffic to and from the 2212, or drops all traffic except for LDAP traffic secured using IPSec to and from the 2212.

### Limitations:

None.

The following table summarizes the Policy Feature configuration changes that are activated when the **GWCON, feature policy, reset, database** command is invoked:

Commands whose changes are activated by the <b>GWCON, feature policy, reset, database</b> command
CONFIG, feature policy, add, policy
CONFIG, feature policy, delete, policy
CONFIG, feature policy, change, policy
CONFIG, feature policy, disable, policy
CONFIG, feature policy, enable, policy

## GWCON, Feature Policy, Reset, LDAP Command

### Description:

The LDAP configuration parameters for the policy feature will be refreshed.

### Network Effect:

The next time the policy database is refreshed, the new LDAP configuration parameters will be used to determine whether to search the server, and, if so, which parameters to use.

### Limitations:

None.

The following table summarizes the Policy Feature configuration changes that are activated when the **GWCON, feature policy, reset, ldap** command is invoked:

Commands whose changes are activated by the <b>GWCON, feature policy, reset, ldap</b> command
CONFIG, feature policy, set, ldap, anonymous-bind
CONFIG, feature policy, set, ldap, bind-name
CONFIG, feature policy, set, ldap, bind-pw
CONFIG, feature policy, set, ldap, policy-base
CONFIG, feature policy, set, ldap, port
CONFIG, feature policy, set, ldap, primary-server
CONFIG, feature policy, set, ldap, retry-interval

## Policy Monitoring Commands (Talk 5)

CONFIG, feature policy, set, ldap, search-timeout
CONFIG, feature policy, set, ldap, secondary-server
CONFIG, feature policy, set, ldap, version
CONFIG, feature policy, enable, ldap, cached-search
CONFIG, feature policy, enable, ldap, policy-search
CONFIG, feature policy, disable, ldap, cached-search
CONFIG, feature policy, disable, ldap, policy-search

### GWCON, Feature Policy, Reset, Refresh

#### Description:

The policy database refresh parameters will be reloaded. The refresh parameters determine whether the database should be automatically refreshed once a day and, if enabled, when during the day.

#### Network Effect:

If the policy refresh feature is enabled, then when the time event specified in the refresh configuration occurs, the policy database will be refreshed. This has the exact effect of manually performing a **reset database** command.

#### Limitations:

None.

The following table summarizes the Policy Feature configuration changes that are activated when the **GWCON, feature policy, reset, refresh** command is invoked:

Commands whose changes are activated by the GWCON, feature policy, reset, refresh command
CONFIG, feature policy, set, refresh

## CONFIG (Talk 6) Immediate Change Commands

The policy feature supports the following CONFIG commands that immediately change the operational state of the device. These changes are saved and are preserved if the device is reloaded, restarted, or you execute a dynamically reconfigurable command.

Commands
CONFIG, feature policy, set, default-policy <b>Note:</b> The next time that the policy database is refreshed, the settings for the default policy will be used during the refresh period and to handle the error conditions that may occur when refreshing the policy database.
CONFIG, feature policy, add, user
CONFIG, feature policy, change, user <b>Note:</b> The pre-shared key defined for the user can be used immediately without restarting or reloading the device. If this user is part of a group associated with the remote user group of a profile, then the policy database must be reset before this association can be made.

## Policy Monitoring Commands (Talk 5)

---

## Chapter 20. Using IP Security

This chapter explains how to use the IP Security feature and contains the following sections:

- “IP Security Overview”
- “IP Security Concepts”
- “Using the Internet Key Exchange” on page 350
- “Using Public Key Infrastructure” on page 352
- “Using Manual IP Security (IPv4)” on page 356
- “Using Manual IP Security (IPv6)” on page 356

---

### IP Security Overview

This section provides an overview of IP security capabilities for both IPv4 and IPv6.

### Using Secure Tunnels

To protect IP packets sent to another host, router, or firewall, you may configure a secure tunnel for each IP route that must be secure. An IPSec tunnel is a two-way logical connection to the remote host, router, or firewall over which a local router sends protected IP packets. A secure tunnel is identified by parameters such as the addresses of the source host and destination host, port numbers, and tunnel ID.

With IPv4 you can define a negotiated tunnel by configuring a tunnel policy in the policy database, or you can create a manual tunnel using the Talk 6 **add tunnel** command as shown at “Configuring the Tunnel for Router A” on page 370. With IPv6, use the Talk 6 **add tunnel** command.

To establish a secure IPSec tunnel, a policy may specify the IP Authentication Header (AH) function (see “IP Authentication Header” on page 344), which attaches special authentication headers, and the IP Encapsulation Security Payload (ESP) function (see “IP Encapsulating Security Payload” on page 344), which encrypts the data. The policy establishes which of the following security measures are implemented for packets:

- AH algorithm and AH authentication keys (See “Configuring the Algorithms” on page 361 or “Configuring the Algorithms” on page 372 as appropriate.)
- ESP encryption algorithm and ESP encryption and decryption keys (See “Configuring the Algorithms” on page 361 or “Configuring the Algorithms” on page 372 as appropriate.)
- Security parameters indexes (SPIs) (See “Security Associations” on page 345.)

**Note:** For each secure tunnel, the sender and the receiver must select identical options.

---

### IP Security Concepts

Packets sent using the Internet Protocol (IP) can be made secure by using the IP Security feature of the 2212.

Security, as defined by RFC 2401 - Security Architecture for the Internet Protocol, consists of the following functions:

#### Authentication

Knowing that the data received is the same as the data that was sent and that the claimed sender is, in fact, the actual sender.

## Using IP Security

### Integrity

Ensuring that data is transmitted from source to destination without undetected alteration.

### Confidentiality

Communicating so that the intended recipients know what was being sent but unintended parties cannot determine what was sent.

### Non-repudiation

Communicating so that the receiver can prove that the sender did, in fact, send certain data even though the sender might later deny ever having sent it.

**Note:** In some countries, encryption support is not provided because of U.S. export regulations, and the encryption parameters are not displayed. However, the ESP-NUL algorithm is always available. For a definition of the ESP-NUL algorithm, see “ESP Encryption Algorithms” on page 345.

## IP Security Terminology

The following terms are used when describing IPsec topics related to IPv4:

### Authentication Header (AH)

A data area containing packet header information, which provides data origin authentication and data integrity and replay protection.

### Certificate

An ASN.1 encoded data item (according to ITU X.509 standards) that binds an end entity's ID to its public key. (In this case, the end entity is the ISAKMP negotiation entity.) The end entity must register its ID and public key with a certificate authority (CA) by submitting a certificate request. The CA verifies the request, signs it, and issues it to the entity. ISAKMP uses the public key certificate during Phase 1 processing to authenticate the initial message exchanges that set up the master secret (cryptographic key) between routers.

### Certificate Authority (CA)

A trusted authority that issues “signed” X.509 digital certificates that network users must use to exchange secure user data using ISAKMP. To participate in secure data exchanges with other ISAKMP-enabled parties, a router must register with a CA and obtain an X.509 digital certificate to be used in authentication.

**Note:** You should check with the CA on a regular basis to ensure that you are using a current list of ISAKMP-enabled parties. See the PKI Talk 6 **load** command at “Public Key Infrastructure Configuration Commands” on page 358 for details.

### Digital Signature

A data item containing a user's encoded ID, which becomes part of an X.509 digital certificate. Users exchange certificates during Phase 1 negotiations to authenticate one another. The signature is generated by performing a public key operation on an input data area to be signed.

### Encapsulating Security Payload (ESP)

An IPsec function that can encapsulate and encrypt a datagram so that its contents cannot be determined by anyone except the recipient. This comprises data integrity and replay protection. ESP also provides data origin authentication. It operates in the following modes: transport mode, which encrypts only the payload of the original datagram, leaving the



addressing information visible to unauthorized parties, and tunnel mode, in which the entire original datagram, including the header, are encrypted. This conceals sensitive address information.

### **Internet Key Exchange (IKE)**

A protocol derived from the ISAKMP and Oakley protocols, which is used by the Internet community to exchange cryptographic keys and authenticate the communicating parties.

### **ISAKMP**

Internet Security Association and Key Management Protocol. This function automatically sets up security associations and manages packets' cryptographic keys for the duration of a data exchange.

### **Management Information Base (MIB)**

A data block sent by a router in response to an inquiry from a central, trusted authority that has requested statistical information about router operations. The authority can detect problems in the network and contact a responsible party to take corrective action.

### **Oakley**

The cryptographic key management protocol used by ISAKMP.

### **Perfect Forward Secrecy (PFS)**

The level of data security obtained if Phase 2 negotiations derive new cryptographic keying information for each negotiation. ISAKMP accomplishes this by enabling the exchange of public Diffie Hellman values between parties. This security feature prevents anyone from determining a current cryptographic key from a previously compromised key.

### **Phase 1 Negotiations**

The communication between a sender and receiver that establishes an ISAKMP security association and cryptographic keys that will protect the ISAKMP messages to be exchanged during Phase 2 negotiations. Phase 1 is processor-intensive, and typically is done infrequently, perhaps only daily or weekly.

### **Phase 2 Negotiations**

The exchange of ISAKMP messages between a sender and receiver during which security associations and cryptographic keys are negotiated that will protect user data exchanges. These negotiations typically happen frequently, perhaps every two to three minutes, and are used to refresh cryptographic keys on a regular basis without user intervention.

**Proxy** A router that is assigned to operate in behalf of another network device.

### **Public Key Infrastructure (PKI)**

The framework that a CA uses to bind the user's ID with its public key and distributes the bound public key in a way that ensures its security.

### **Quick Mode**

The term used to describe the Phase 2 negotiations for non ISAKMP security associations.

### **Replay**

The act of capturing a datagram and either attempting to determine its contents or mounting a denial-of-service attack by resending it repeatedly.

### **Security Association (SA)**

A data area tying together information about a data packet, such as its cryptographic algorithm and key information, the identities of the participating parties, and so forth.

## Using IP Security

### Transform

A named collection of information about a configuration of authentication and encryption selections.

## IP Authentication Header

The Authentication Header (AH) is described in RFC 2402 IP Authentication Header. This header contains authentication data for the IP datagram.

For IPv4 using negotiated IPsec, the policy assigned to a datagram implements a cryptographic authentication function that relies upon the Internet Key Exchange (IKE) protocol and a public/private key pair. For IPv4 manual tunnels and for IPv6, the sender uses a cryptographic function that relies upon a secret authentication key. In either case, the cryptographic authentication function is applied to the contents of the datagram. You may specify AH alone or with ESP. See “Using AH and ESP” on page 345 for details.

### AH Authentication Algorithms

A secure tunnel that uses the AH tunnel policy must use one of the following authentication algorithms:

- HMAC-MD5 IP Authentication with Replay Prevention
- HMAC-SHA-1 IP Authentication with Replay Prevention

These AH algorithms combine a keyed message authentication function using cryptographic hashing (hashed message authentication code, abbreviated as HMAC) with an optional replay prevention function. Replay prevention uses a sequence number contained in the AH to verify that a packet has not been received previously. Replay prevention protects the receiver from denial-of-service attacks, in which the same packet is sent repeatedly and the router becomes so busy processing the duplicate packets that it cannot process legitimate traffic. An authentication code is applied to a secret cryptographic key and the data, then to the output of the secret key and the output of the first operation. See Figure 33 for an illustration of how this is done for HMAC-MD5.

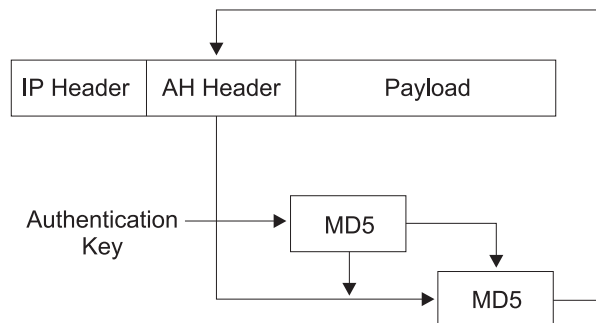

Figure 33. Creation of an HMAC MD5-Authenticated Message

## IP Encapsulating Security Payload

IP Encapsulating Security Payload (ESP) is described in RFC 2406 IP Encapsulating Security Payload. ESP encrypts part or all of the IP packet to provide confidentiality in addition to authentication (optional) and integrity. However, if you select the ESP-NUL algorithm, ESP performs only authentication and integrity checking. You may specify ESP alone or with AH. See “Using AH and ESP” on page 345 for details.

### ESP Authentication Algorithms

The algorithms available for ESP authentication are the same as those for AH, previously shown at “AH Authentication Algorithms” on page 344.

### ESP Encryption Algorithms

A secure tunnel that uses the ESP encryption policy must either use one of the following encryption algorithms or the ESP-NULL algorithm:

- Data Encryption Standard in Cipher Block Chaining Mode (DES-CBC)
- Commercial Data Masking Facility (CDMF)
- Triple DES (3DES)

**Note:** Except for ESP-NULL, the ESP encryption algorithms are subject to U.S. export laws. If your 2212 does not allow you to use some or all of these algorithms, sale of those algorithms may be prohibited in your country. Check with your IBM representative for more information.

The ESP-NULL algorithm does not encrypt the cleartext data and is available in all countries. It enables ESP authentication and integrity checking only, not encryption. If you use ESP-NULL, you *must* use one of the ESP authentication algorithms.

## Using AH and ESP

A secure tunnel may use one of the following authentication/encryption selections: AH, ESP, AH-ESP, or ESP-AH. If you want a combination of AH and ESP, the following statements apply:

- The policy AH-ESP specifies that for outbound packets, encryption runs before authentication. In this case, in the destination router the AH authentication function runs first, checking inbound packets, and only packets that pass authentication are forwarded to ESP for decryption.
- The policy ESP-AH specifies that for outbound packets, authentication runs before encryption. In this case, in the destination router the ESP function first decrypts inbound packets, and only packets that are decrypted successfully are forwarded to AH authentication.

## Security Associations

A Security Association (SA) is a simplex “connection” that affords security services to the traffic carried by it. Security services are afforded to an SA by the use of AH or ESP, but not both. If both AH and ESP protection are applied to a traffic stream, then two (or more) SAs are created to afford protection to the traffic stream. To secure typical bidirectional communication between two hosts or between two security gateways, two SAs (one in each direction) are required.

## Tunnel Mode and Transport Mode

The operational mode (either tunnel or transport) determines how IPSec handles IP packets. Tunnel mode is the default, and is required if the router is acting as a security gateway. It protects data on a single segment of a path through a network. Transport mode is allowed only when the router is acting as a host, and protects data end-to-end, along a complete path.

### AH and Operational Modes

In tunnel mode, the AH is placed in front of the IP packet and a new IP header is created and placed in front of the AH. The IP header of the packet being tunnelled (inner header) carries the ultimate source and destination addresses of the packet. The new IP header (outer header) can contain the addresses of security gateways,

## Using IP Security

which are the tunnel endpoints. The AH protects the entire new packet, both the new IP header and the IP packet being tunnelled, except for the mutable fields in the new IP header.

In transport mode, the AH is inserted after the IP header and before the header of an upper-layer protocol, such as TCP or UDP. In this mode, AH authenticates the upper-layer protocol header and the contents of the IP packet, except for the mutable fields in the IP header (such as time-to-live [TTL], checksum, fragment flag, fragment offset, and type of service [TOS]).

Figure 34 shows the format of AH-protected datagrams.

Original Datagram



Original Datagram Protected by AH Tunnel Mode



← Authenticated except for mutable fields in New IP header →

Original Datagram Protected By AH Transport Mode

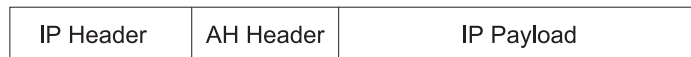

← Authenticated except for mutable fields in IP header →

Figure 34. AH-Protected Datagram Format

### ESP and Operational Modes

In tunnel mode, the payload data contains the entire IP packet, and a new IP header is created and placed in front of the ESP header. The IP header of the packet being tunnelled (inner header) contains the ultimate source and destination addresses of the packet, while the new IP header (outer header) contains the addresses of security gateways. ESP encrypts the tunnelled IP packet. If you use ESP authentication, the ESP header, the tunnelled IP packet, and the ESP trailer are authenticated.

In transport mode, the payload data contains encrypted upper-layer protocol data, such as TCP or UDP data. If you use authentication, the ESP header, the upper-layer protocol data, and the ESP trailer are authenticated.

Figure 35 on page 347 shows the format of ESP-protected datagrams.

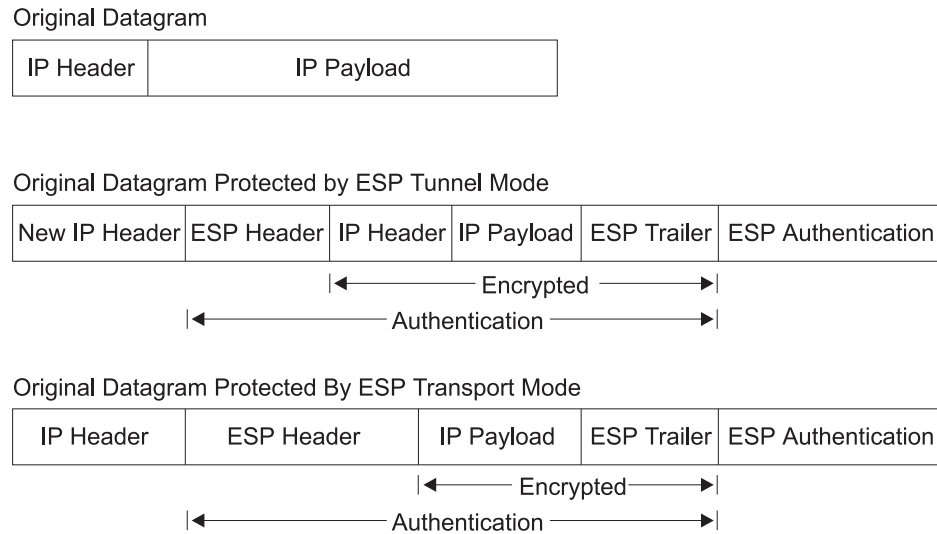
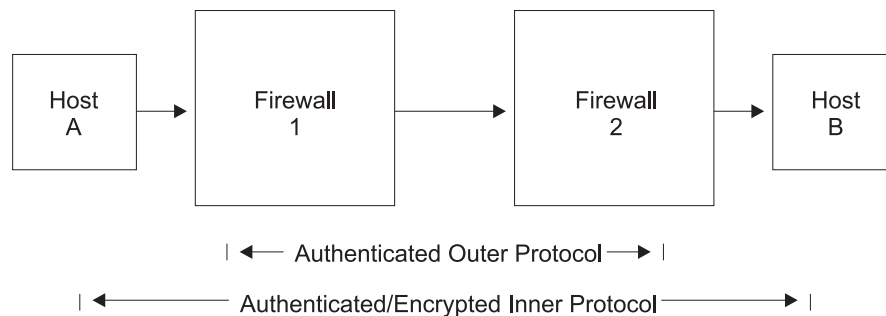

Figure 35. ESP-Protected Datagram Format

### Nesting AH and ESP

You may nest one protocol within another instance of itself or the other protocol. Figure 36 shows the effects of nesting an ESP-protected datagram within an AH tunnel.



Host A uses ESP Transport



Firewall 1 uses AH Tunnel, adding new IP Header



Firewall 2 receives AH-tunnelled datagram, authenticates it, strips off outer header and AH header



Figure 36. Nesting ESP Within an AH Tunnel

### Using IP Security with L2TP Packets

With IPv4, you may also use IPSec to protect L2TP packets. After creating an L2TP tunnel by encapsulating an L2TP frame inside a UDP packet, you may encapsulate the UDP packet inside an IP packet whose source and destination addresses define

## Using IP Security

the tunnel's end points. Then you can apply AH, ESP, and ISAKMP protocols to the IP packet. Figure 37 shows an IP-encapsulated L2TP packet including PPP and its payload protocol for transmission across the Internet.

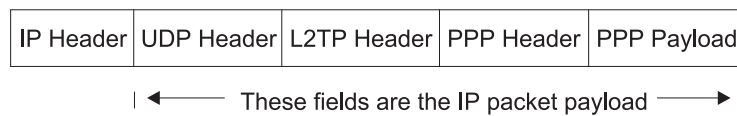

Figure 37. IPsec-Protected L2TP Packet

## Tunnel-in-Tunnel Mode

For greater security, in addition to the security features already discussed, you may encapsulate the packets of a traffic stream twice and transmit them first through one IPsec tunnel and then through another (tunnel-in-tunnel).

**Note:** The use of multiple encryption (using tunnel-in-tunnel mode when encryption is preformed for both tunnels) within the router is restricted by U.S.A. Government export regulations. It is only supported in software loads that are under strict export control (software loads that support RC4 with 128 bit keys and Triple DES).

With IPv4, a rule in the policy database designates a packet for encapsulation (inner) for the first tunnel, and before the packet is sent, the rule causes the packet to be submitted to a second tunnel for a second encapsulation (outer). With IPv6, a packet filter access control rule identifies a packet for encapsulation (inner) for the first tunnel, and before the packet is sent, a second rule causes the packet to be submitted to a second tunnel for a second encapsulation (outer).

The two IPsec tunnels originate in the same router and the remote ends of the tunnels are at the same physical location, but on different machines. The remote end of the first tunnel can be either a secure gateway or a host; the remote end of the second tunnel *must* be a secure gateway router. Because the tunnels have different destinations, they must have different remote IP addresses. Both tunnels used for tunnel-in-tunnel must be configured for tunnel mode, and extra padding is not allowed on the second tunnel.

After it has been encapsulated twice, the packet is transmitted through the second (outer) tunnel. At the end of that tunnel, the outer encapsulation is removed and the packet is forwarded to the first tunnel (inner), based on information in the header created by the first tunnel encapsulation. At the end of this tunnel, the inner encapsulation is removed and the packet is forwarded to its final destination.

## Path Maximum Transmission Unit Discovery

For both IPv4 and IPv6, IPsec supports Path Maximum Transmission Unit (PMTU) Discovery if the 2212 is acting as a security gateway. Support of PMTU Discovery is a concern if a packet cannot be fragmented. With IPv4, a packet cannot be fragmented if the Don't Fragment (DF) bit is set. With IPv6, a packet cannot be fragmented by intermediate routers. In these situations, if the packet does not fit on a link in the path from one end of the secure tunnel to the other, a "packet too big" ICMP error message is sent to the packet originator.

Because the router is acting as a security gateway, the error packet is returned to the originating router instead of the true originator of the packet. The receiving router must pass the reported MTU back to the true originator, who can reduce the

packet size so that it will reach the final destination. Support for PMTU Discovery is discussed in RFC 2401 - Security Architecture for the Internet Protocol.

IPv4 provides the following options for the DF bit setting in the outer header of the tunnelled packet:

1. Copy from the inner header
2. Always set
3. Always clear

These options are available when configuring secure tunnel-in-tunnel mode, for example, using the policy feature **add ipsec-manual-tunn** (IPv4) or the Talk 6 **add tunnel** (IPv6) command. The DF bit is handled according to the option selected except under the following conditions:

- The tunnel MTU is equal to the minimum MTU.
- The incoming packet size is less than or equal to the minimum MTU.
- The encapsulated packet size would be greater than the minimum MTU.

In these circumstances, for IPv4, the DF bit is not set, regardless of the configuration, and the secure packet may be fragmented as needed on the path to the receiver. For IPv6, the packet is fragmented as needed as it leaves the security gateway so that it fits on the PMTU for the tunnel. This special action is needed because the incoming packet is already less than or equal to the minimum MTU, so the originating host will not decrease the size any further. If fragmentation were not allowed, this packet would never reach its final destination

Because changes in the network topology or configuration can change the PMTU, the PMTU value must be aged out periodically and reset to the maximum. The aging timer value defaults to 10 minutes and can be configured with the Talk 6 **set path** command. Setting the aging parameter to 0 disables PMTU aging.

### Diagram of a Network with an IP Security Tunnel

Figure 38 on page 350 shows an example of a network with two IPSec tunnels that connect router A (with IPSec) to router B (with both IPSec and Network Address Translation for IPv4).

## Using IP Security

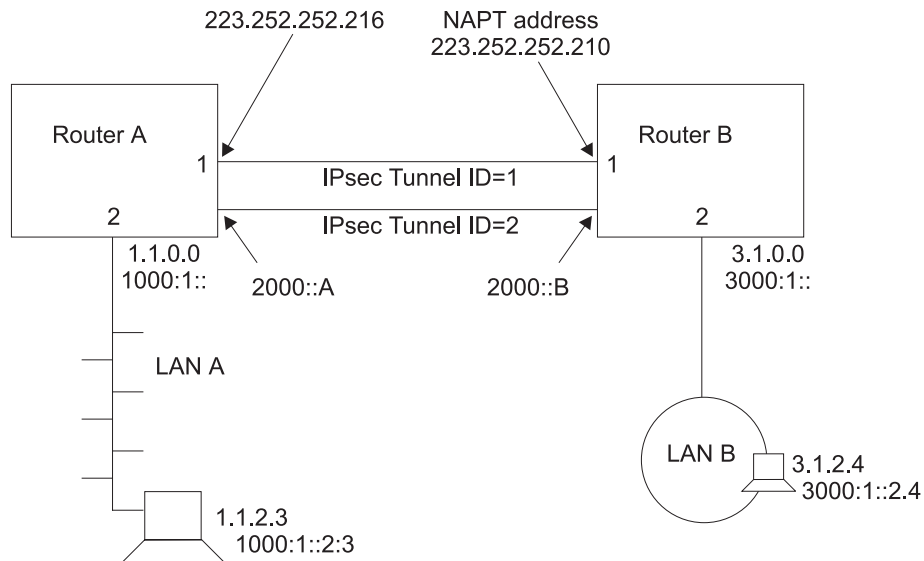

Figure 38. Network with IPsec and NAT

In this network, an IPsec tunnel with IPsec tunnel ID 1 has been configured from IPv4 address 223.252.252.216 in router A to IPv4 address 223.252.252.210 in router B. Router A is configured for IPsec. Router B is configured for both IPsec and NAT.

Also in this network, an IPsec tunnel with IPsec tunnel ID 2 has been configured from IPv6 address 2000::A in Router A to IPv6 address 2000::B in Router B.

With IPv4, to configure this network for IKE, follow the steps starting at “Configuring Internet Key Exchange (IPv4)” on page 357. For IPv4 with manual IPsec, follow the steps starting at “Configuring a Manual Tunnel (IPv4)” on page 370. For IPv6, follow the steps starting at “Configuring a Manual Tunnel (IPv6)” on page 373.

**Note:** Even if you do not plan to use NAT in your network, the description of configuring router B can help you understand the relationships between the parameters at each end of the IPsec tunnel more clearly.

---

## Using the Internet Key Exchange

This section explains how you can use the Internet Key Exchange (IKE) to automate the definition and creation of IPsec security associations (SAs). IKE is a standard supported by the IETF (RFC 2409), which provides a standard way for IPsec-enabled products from the same or different vendors to communicate about their security requirements.

IKE provides a framework by means of which the following security requirements are met:

### Authentication of the remote negotiating entity (IKE peer)

Through the use of either a pre-shared key or a digital certificate, IKE authenticates the identity of the entity you are communicating with by making the entity prove it is who it claims to be.

### Creation of identical keying material in both peers

By using the Diffie-Hellman public key/private key mechanism, IKE provides



for the exchange of the public key component and for the independent generation of identical keys by each peer.

### Provide protection for the negotiation of IPSec security associations

Through a two-phase process, described in the following topic, IKE provides for the creation of security associations that are used solely to protect the negotiation of IPSec *tunnels*, and for the actual negotiation and creation of *security associations* that IPSec uses to protect user data.

## Internet Key Exchange Phases

IKE defines two distinct negotiation exchanges: Phase 1 and Phase 2. Phase 1 sets up a secure tunnel between the two IKE peers, which will provide protection for the subsequent IPSec tunnel negotiations. The following actions occur during Phase 1 in the order shown:

1. The characteristics of the Phase 1 security association are negotiated and agreed upon by the IKE peers. These characteristics include the encryption algorithm that will be used to encrypt *the IKE communications*, the hash algorithm to be used, the authentication method, and the Diffie-Hellman group to be used when generating keys.
2. The Diffie-Hellman keys are generated and the public portions are exchanged with the IKE peer. These keys are used to generate encryption keys that will encrypt both the Phase 1 negotiations and will also allow the generation of keys that will be used by IPSec tunnels.
3. The IKE peer is authenticated using one of two supported methods—pre-shared key mode and signature mode.

In pre-shared key mode, both IKE peers, by means of a previous off-line process, have exchanged a key, and this is used during Phase 1 to authenticate the peer. You configure the pre-shared key using the policy feature's **add user** command.

In signature mode, a signed X.509 digital certificate is used to provide keys that are used to encrypt and decrypt the payloads of Phase 1 messages. Successful signing and verifying comprises authentication of the peer. For a detailed discussion of signature mode and the use of X.509 digital certificates, see “Using Public Key Infrastructure” on page 352.

Phase 1 negotiations can take place using either of two exchange modes:

- Main mode uses six messages to perform the Phase 1 negotiations and encrypts the identities of the negotiating peers.
- Aggressive mode uses three messages to perform the Phase 1 negotiations. The peers exchange unprotected identities in the first two messages.

## Negotiating an IP Security Tunnel

The processing discussed in this topic occurs when a router prepares to send a packet whose attributes match those defined in a rule in a policy database. Negotiating a tunnel occurs in two phases. During Phase 1, the sending router initiates communication by transmitting the first message of a six-message exchange, which establishes the security options to be used during Phase 2. The receiver responds and the two parties negotiate the ISAKMP security association (SA) characteristics, the authentication and encryption algorithms to be used, and they authenticate each other's identity. During Phase 2, the parties exchange a total of three messages to negotiate the SAs and keys to be used to protect IP datagrams sent between the two. Phase 1 proceeds as follows:

1. Message 1: The sender proposes how the communication activity will take place—the authentication method (for example, digital signatures), the

## Using IP Security

authentication algorithm (for example, HMAC-MD5), and the encryption algorithm (for example, DES-CBC) to be used.

2. Message 2: The receiver indicates to the sender which, if any, of the security options it will support.
3. Message 3: The sender transmits its Diffie Hellman public value and a random value from which encryption keys will be created.
4. Message 4: The receiver transmits its own Diffie Hellman public value and a random value from which encryption keys will be created. At this point, both parties create public and private keys and key-related information to be used in ISAKMP message exchanges.
5. Message 5: The sender transmits a digital signature and may include an X.509 digital certificate signed by a trusted certificate authority (CA). If the sender does not include a valid certificate, the receiver must use the LDAP protocol to obtain a certificate from either a trusted CA, a secure DNS server, a secure local cache that maps previously used certificates to their respective ID values, or may request a certificate from the sender, who must immediately send it.
6. Message 6: After verifying the sender's digital signature, the receiver transmits the same kind of identifying information about itself to the sender.

At this point, both parties have authenticated themselves to the other, agreed on the characteristics of the SA, and have derived keys and key-related information for handling ISAKMP SAs. Now the parties enter Phase 2 to negotiate the non ISAKMP SAs and keys, which will be used to protect IP datagrams exchanged between them. Phase 2 proceeds as follows:

1. Message 1: The sender proposes a non ISAKMP SA by transmitting an AH or ESP algorithm selection, and also includes other security-related information.
2. Message 2: The receiver indicates to the sender which proposal it has selected, and also includes security-related information.
3. Message 3: The sender transmits a hash record of several items to indicate to the receiver that it is ready to proceed using the negotiated security protocols. When the receiver verifies the information, the link is complete and the parties can begin to exchange protected data streams.

---

## Using Public Key Infrastructure

This section explains how to use the public key infrastructure (PKI). Through PKI, IKE supports public key signature mode for authenticating IKE entities. Although this release supports pre-shared key mode, which does not require PKI support, this mode contains an inherent disadvantage. For authentication, it requires that you configure each IKE entity with the pre-shared key of each of its peers. This severely limits the scalability of IKE operations. Public key-based signature or public encryption mode provides much better scalability. In this release, the X.509 digital certificate is used in signature mode IKE Phase 1 negotiations to authenticate IKE entities.

You assign an identity to each IKE entity that you want to participate in IKE negotiations by specifying a unique value in the ISAKMP ID field when you configure its user policy profile. Each IKE entity authenticates its identity with its peers.

PKI is currently being defined and developed to support public key operation. In PKI, an X.509 digital certificate binds an entity's public key to its claimed identity. An IKE entity can extract the public key contained in a certificate. It can then perform a public key operation to authenticate the identity of a peer that is participating in an

IKE negotiation. A public key is used for IKE signature mode. In this mode, the signer uses its private key to sign the digital signature. The receiver extracts the signer's public key from the certificate and uses it to verify the signature. The digital certificate function provides a scalable way for one IKE entity to authenticate the identity of another IKE entity.

## Configuring PKI

This release assumes that both IKE entities in a negotiation use the same CA. Before starting IKE negotiations using the signature, you must configure PKI for the router. You must also generate the router private key and router certificate, and have downloaded the root CA's certificate. The following steps explain how to configure PKI:

1. Generate the key pair and request the certificate.

Because public key operation involves a key pair (signature mode uses the private key to sign and the public key to verify), you must generate a key pair for the router. For a certificate request, you must send the generated public key to the CA to be put into an X.509 digital certificate. Then every potential IKE peer can extract this public key from the CA-issued certificate. The private key resides in the router and is kept secret, known only to the router.

In this version, you may issue a **certificate request** command, which does the following:

- a. Generates a key pair, whose key length you may specify as either 512, 768, or 1024 bits. The generated private key stays in cache.
  - b. Requests that you enter information to include in the certificate request (for example, the router ID in the form of the IP address, domain name, or email name.
  - c. Creates a certificate request (in PKCS#10 format) containing the generated public key and the information you have entered.
  - d. TFTP's the certificate request to a host machine.
2. Issue the certificate (outside the router)

The CA receives the PKCS#10 certificate request. The CA may manually verify the request and issue a certificate. The certificate contains the router public key and the information that you entered. The CA signs the certificate using its private key, thus it becomes trusted digital information as long as you trust the signing CA. The certificate is now ready to be used in IKE negotiations. (This processing is outside the scope of the router operation and is not discussed in further detail in this book.)

3. Download the router certificate

Once the CA has issued the certificate, PKI can download it into the router. Depending on how the CA publishes the certificate, PKI can use either TFTP or LDAP to do the download.

Note that the private key and the public key in the router certificate must match in order to perform public key operation such as digital signature. When PKI downloads the certificate into the router, the private key that was generated with the public key must be in the router key cache. The downloaded certificate is useless if it loses its matching private key. This means that from the time you issue the certificate request to the time the certificate downloads, you **must not** restart or reload the router, clear cache, or issue a new certificate request. Any of these operations destroy the private key in the router running cache.

4. Download the CA certificate

To verify the IKE peer's certificate, PKI must obtain the peer's root CA certificate. This release supports single level CA operation, which means that

## Using IP Security

the IKE entities must be assigned to the same CA. Each IKE entity (in this case, each router) must download the CA's certificate (using either TFTP or LDAP) to verify that the certificate received from the peer is valid.

### 5. Save and reload the certificate

After the router has obtained the certificate, its matching private key, and the CA's certificate, you can start IKE negotiation. Since a certificate is typically valid for months or years, you may want to save the certificate and the private key in SRAM so that you do not have to issue a certificate request and do a download each time you reload or restart the router. This version provides the **cert save** and **cert load** commands to save or retrieve the certificate and private key in SRAM.

Note that the router certificate and private key must be processed as a pair (for example, they are always saved or retrieved from SRAM together).

Use Talk 6 commands to configure and list both TFTP and LDAP server information as shown in the following examples:

### Example: Add Server (T6)

```
Config>f ipsec
IP Security feature user configuration
IPsec config>pki
PKI config>add server
Name ? (max 65 chars) []? test
Enter server IP Address []? 8.8.8.8
Transport type (Choices: TFTP/LDAP) [TFTP]?
PKI config>
```

### Example: List Server Configuration (T6)

```
PKI config>li server

1) Name: SERVER1
   Type: TFTP
   IP addr: 8.8.8.8

2) Name: TEST
   Type: TFTP
   IP addr: 8.8.8.8
```

### Example: List Root Certificate (T6)

```
PKI config>li cert

Root CA certificate:
  SRAM Name: R1
  Subject Name: /c=US/o=ibm/ou=nhd
  Issuer Name: /c=US/o=ibm/ou=nhd
  Validity: 1998/12/19 -- 2018/12/19
  Default Root Cert: No

  SRAM Name: R2
  Subject Name: /c=US/o=ibm/ou=nhd
  Issuer Name: /c=US/o=ibm/ou=nhd
  Validity: 1998/12/19 -- 2018/12/19
  Default Root Cert: Yes

Router Certificate:
  SRAM Name: B1
  Subject Name: /c=CA/o=Entrust Technologies/ou=PartnerCA/cn=ibm3
  Issuer Name: /c=CA/o=Entrust Technologies/ou=PartnerCA
  Subject alt Name: 1.1.1.1
  Key Usage: Sign & Encipherment
  Validity: 1998/10/29 -- 2001/10/29
  Default Cert: No
```

```

SRAM Name: B2
Subject Name: /c=CA/o=Entrust Technologies/ou=PartnerCA/cn=ibm3
Issuer Name: /c=CA/o=Entrust Technologies/ou=PartnerCA
Subject alt Name: 1.1.1.1
Key Usage: Sign & Encipherment
Validity: 1998/10/29 -- 2001/10/29
Default Cert: Yes

SRAM Name: B3
Subject Name: /c=CA/o=Entrust Technologies/ou=PartnerCA/cn=ibm3
Issuer Name: /c=CA/o=Entrust Technologies/ou=PartnerCA
Subject alt Name: 1.1.1.1
Key Usage: Sign & Encipherment
Validity: 1998/10/29 -- 2001/10/29
Default Cert: No

SRAM Name: YYY
Subject Name: /c=CA/o=Entrust Technologies/ou=PartnerCA/cn=ibm3
Issuer Name: /c=CA/o=Entrust Technologies/ou=PartnerCA
Subject alt Name: 1.1.1.1
Key Usage: Sign & Encipherment
Validity: 1998/10/29 -- 2001/10/29
Default Cert: No

```

### Example: Certificate Request (T5)

```

PKI Console>cert-req
Enter the following part for the subject name
Country Name(Max 16 characters) []? us
Organization Name(Max 32 characters) []? IBM
Organization Unit Name(Max 32 characters) []? NHD
Common Name(Max 32 characters) []? router1
Key modulus size
[512]?
Certificate subject-alt-name type:
1--IPv4 Address
2--User FQDN
3--FQDN
Select choice [1]?
Enter an IPv4 addr) []? 12.1.1.1
Generating a key pair. This may take some time. Please wait ...
PKCS10 message successfully generated
Enter tftp server IP Address []? 8.8.8.8
Remote file name (max 63 chars) [/tmp/tftp_pkcs10_file]?
Memory transfer starting.
.Memory transfer completed - successfully.
Certificate request TFTP to remote host successfully.
Private Key Alias [ROUTER_KEY]? local
Generated private key LOCAL stored into cache

```

### Example: List Router Certificate (T5)

```

PKI Console>li cert
Router certificate
Serial Number: 909343811
Subject Name: /c=CA/o=Entrust Technologies/ou=PartnerCA/cn=ibm3
Issuer Name: /c=CA/o=Entrust Technologies/ou=PartnerCA
Subject alt Name: 1.1.1.1
Key Usage: Sign & Encipherment
Validity: 1998/10/29 -- 2001/10/29

Root CA certificate
Serial Number: 914034740
Subject Name: /c=US/o=ibm/ou=nhd
Issuer Name: /c=US/o=ibm/ou=nhd
Validity: 1998/12/19 -- 2018/12/19

```

### Example: Cert Save (T5)

```

PKI Console>cert-save
Enter type of certificate to be stored into SRAM:
1)Root certificate;
2)Box certificate with private key;
Select the certificate type (1-2) [2]?

```

## Using IP Security

```
SRAM Name for certificate and private key []? yyy  
Load as default router certificate at initialization?? [No]:  
Private key YYY written into SRAM  
Both Certificate and private key saved into SRAM successfully  
PKI Console>
```

### Example: Cert Load (T5)

```
PKI Console>cert-load  
Enter type of certificate to be stored into SRAM:  
  1)Root certificate;  
  2)Box certificate with private key;  
Select the certificate type (1-2) [2]?  
Name []? yyy  
Box certificate and private key saved into cache successfully  
PKI Console>
```

---

## Using Manual IP Security (IPv4)

The IP security feature contained in IPv4 for the 2212, in conjunction with the policy feature and other IPSec-related processes, provides authentication, integrity, confidentiality, and non-repudiation. To implement IPSec manually, you preconfigure a policy containing a subset of IPSec options in a policy database to define the manual tunnel's profile and validity period. You may also preconfigure the full set of IPSec options (policy) in the database so that when a policy-enabled router prepares to send an IPSec packet, it dynamically negotiates and establishes IPSec options with the destination router, based on the policy's contents. To define a manual tunnel, see "Configuring Manual IP Security (IPv4)" on page 361. For an explanation of the policy options, see "Chapter 18. Using the Policy Feature" on page 271.

---

## Using Manual IP Security (IPv6)

The IP security feature contained in IPv6 for the 2212 provides authentication, integrity, and confidentiality. To define a manual tunnel, see "Configuring Manual IP Security (IPv6)" on page 372.

---

## Chapter 21. Configuring and Monitoring IP Security

This chapter describes how to configure and monitor IP security and how to use the IP security monitoring commands. For IPv4, “Chapter 18. Using the Policy Feature” on page 271 and “Chapter 19. Configuring and Monitoring the Policy Feature” on page 309 provide additional information about configuring and monitoring IP security policies. This chapter contains the following sections:

- “Configuring Internet Key Exchange (IPv4)”
- “Configuring Public Key Infrastructure (IPv4)”
- “Obtaining a Certificate” on page 358
- “Public Key Infrastructure Configuration Commands” on page 358
- “Configuring Manual IP Security (IPv4)” on page 361
- “Accessing the IP Security Configuration Environment” on page 362
- “Manual IP Security Configuration Commands” on page 362
- “Configuring a Manual Tunnel (IPv4)” on page 370
- “Configuring Manual IP Security (IPv6)” on page 372
- “Accessing the IP Security Configuration Environment” on page 372
- “Manual IP Security Configuration Commands” on page 373
- “Configuring a Manual Tunnel (IPv6)” on page 373
- “Monitoring Manual IP Security (IPv4)” on page 376
- “Monitoring Manual IP Security (IPv6)” on page 387
- “IP Security Dynamic Reconfiguration Support” on page 387

**Note:** If you create an IPSec tunnel to transport TN3270, APPN<sup>®</sup>-ISR, or APPN-HPR traffic and you plan to prioritize that traffic using BRS, you need to use the IPv4 precedence bit setting feature of BRS. See “Using IP Version 4 Precedence Bit Processing for SNA Traffic in IP Secure Tunnels and Secondary Fragments” on page 9 for more information.

---

### Configuring Internet Key Exchange (IPv4)

This topic explains how to configure Internet Key Exchange (IKE).

Before establishing an IPSec tunnel, you must:

1. Configure the attributes of packets that will use the tunnel and the resulting actions to be taken (the policy).
2. Configure the encryption and authentication options that you want.

For details about doing these tasks, see “Chapter 18. Using the Policy Feature” on page 271, “Chapter 19. Configuring and Monitoring the Policy Feature” on page 309 and “Configuring Public Key Infrastructure (IPv4)”.

---

### Configuring Public Key Infrastructure (IPv4)

This topic explains how to configure the Public Key Infrastructure (PKI) with IPv4.

Before establishing an IPSec tunnel, you must:

1. Create a public/private cryptographic key pair and obtain a digital certificate from a trusted Certificate Authority (CA). See “Obtaining a Certificate” on page 358 for details.
2. Decide which IPSec algorithms, SAs, and other options you want to use for the routers whose policies you are configuring. See “Negotiating an IP Security Tunnel” on page 351 and the subsequent topics for details.

## Configuring Public Key Infrastructure

3. Configure IKE and the policy database. See “Configuring Internet Key Exchange (IPv4)” on page 357, “Chapter 18. Using the Policy Feature” on page 271, and “Chapter 19. Configuring and Monitoring the Policy Feature” on page 309 for details.

---

## Obtaining a Certificate

Before establishing an IPsec tunnel, you must select and register with a trusted Certificate Authority (CA) as described at “Using Public Key Infrastructure” on page 352. The CA returns a signed X.509 digital certificate, which allows you to identify and authenticate yourself to other parties in the network. The certificate consists of an encoded digital ID (signature) and a public/private cryptographic key pair. Do the following:

1. Identify a CA and obtain its server address.
2. Configure the certificate repository retrieval options using either the PKI Talk 6 **add ldapserver** or **add tftpserver** command as described at “Public Key Infrastructure Configuration Commands”.
3. Create a public/private key pair using the PKI Talk 5 **certificate request** command as described at “Public Key Infrastructure Monitoring Commands” on page 378. You may do this either in the router or remotely, for example, acting as the Virtual Private Network (VPN) administrator, in which case you must encrypt and securely transfer the key pair into the router.
4. Submit an initial certificate request to the CA using the PKI Talk 5 **certificate request** command as described at “Public Key Infrastructure Monitoring Commands” on page 378. The request is sent in a PKCS#10 message through either email or FTP. The CA binds the key pair into the certificate, signs it with the CA’s private key, and either stores it in a central (LDAP or FTP) repository or returns it to you in a PKCS#7 message. Typically, a certificate is valid for several months or longer, then is renewed. This identifies which parties in a network can still be trusted.
5. Save the certificate into a router’s SRAM using the PKI Talk 5 **certificate save** command as described at “Public Key Infrastructure Monitoring Commands” on page 378.

### Notes:

1. To display a list of certificate records in SRAM, use the PKI Talk 6 **list certificate** command as described at “Public Key Infrastructure Configuration Commands”.
2. To delete certificate records from SRAM, use the PKI Talk 6 **delete certificate** command as described at “Public Key Infrastructure Configuration Commands”.
3. To eliminate the need to resubmit a certificate request during future IPsec negotiations, use the PKI Talk 5 **certificate load** command as described at “Public Key Infrastructure Monitoring Commands” on page 378 to load the received certificate in cache.

---

## Public Key Infrastructure Configuration Commands

### Add

Use the PKI Talk 6 **add** command to configure the certificate repository server and its location.

#### Syntax:

```
add server
```



## Public Key Infrastructure Configuration Commands

**server** Specifies that the add operation is for a server.

### Example 1: Adding a server

```
PKI config>add server
Name ? (max 65 chars) []? myldap
Enter server IP Address []? 8.8.8.9
Transport type (Choices: TFTP/LDAP) [TFTP]? ldap
LDAP search timeout value [3]?
LDAP retry interval (mins) [1]?
LDAP server port number [389]?
LDAP version [2]?
Bind to the server anonymously? [No]:
Enter your bind DN: []? c=us o=ibm
Enter your bind PW: []? testldap
```

## Change

Use the PKI Talk 6 **change** command to change the certificate repository server and its location.

### Syntax:

```
change server
```

**server** Specifies that the add operation is for a server.

### Example 1: Changing a server

```
PKI config>change server
Name []? myldap
Enter server IP Address []? 8.8.8.7
Server type will continue to be LDAP
LDAP search timeout value [3]?
LDAP retry interval (mins) [1]?
LDAP server port number [389]?
LDAP version [2]?
Enter your bind DN: [c=us o=ibm]?
Enter your bind PW: [testldap]?
```

## Delete

Use the PKI Talk 6 **delete** command to delete a certificate record or a private key record from a router's SRAM, or to delete a server.

### Syntax:

```
delete certificate
private-key
server
```

### certificate

Specifies that the delete operation is for one or more certificate records.

**all** Specifies that all certificate records are to be deleted.

**id** Specifies the ID of the certificate record to be deleted.

### Example 1: deleting a certificate

```
PKI config>delete certificate
Cert Name []? test
Enter the type of the certificate:
Choices: 1-Root CA Cert, 2-Router Cert
Enter (1-2): [2]?
Box Certificate [TEST] deleted successfully
Corresponding private Key [TEST] deleted successfully
```

## Public Key Infrastructure Configuration Commands

### Example 2: Deleting private keys

```
PKI config>delete private-keys
Private Key Name []? test
Private Key [TEST] deleted successfully
Corresponding box certificate [TEST] deleted successfully
```

### Example 3: Deleting server records

```
PKI config>delete server
Name []? myldap
Server MYLDAP deleted successfully
```

#### private-key

Specifies that the delete operation is for one or more private key records.

**server** Specifies that the delete operation is for a server.

## List

Use the PKI Talk 6 **list** command to list certificate or key records in a router's SRAM, or to display the certificate revocation list (CRL—a list of ISAKMP-enabled parties whose certificates have been revoked). To obtain the current CRL, use the PKI Talk 6 **load** command.

#### Syntax:

```
list                certificates
                    crl
                    private-keys
                    servers
```

#### certificates

Specifies that the list operation is for the certificate records.

**crl** Specifies that the list operation is for the certificate revocation list.

#### private-keys

Specifies that the list operation is for the private key records.

#### servers

Specifies that the list operation is for the server records.

### Example: Listing certificates

```
PKI config>list certificates

Root CA certificate:
  SRAM Name: B
  Subject Name: /c=US/o=ibm/ou=nhd
  Issuer Name: /c=US/o=ibm/ou=nhd
  Validity: 1998/12/19 2:2:21 -- 2018/12/19 2:32:21
  Default Root Cert: Yes

Router Certificate:
  SRAM Name: W
  Subject Name: /c=US/o=ibm/ou=nhd/cn=testip
  Issuer Name: /c=US/o=ibm/ou=nhd
  Subject alt Name: 1.1.1.1
  Key Usage: Sign & Encipherment
  Validity: 1999/1/19 23:24:27 -- 2002/1/19 23:54:27
  Default Cert: No
```

### Example: Listing crl

## Public Key Infrastructure Configuration Commands

```
PKI config>list crl
```

### Example: Listing private keys

```
PKI config>list private-keys  
Private Keys In SRAM:
```

```
1) Name W
```

### Example: Listing server records

```
PKI config>list servers  
1) Name: SERVER1  
   Type: LDAP  
   IP addr: 1.1.1.2  
     LDAP search timeout (secs): 10  
     LDAP retry interval (mins): 3  
     LDAP server port number: 390  
     LDAP version: 2  
     Anonymous bind ?: y  
  
2) Name: TEST  
   Type: TFTP  
   IP addr: 8.8.8.8
```

## Load

Use the PKI Talk 6 **load** command to retrieve the most current certificate revocation list (CRL) from the CA. You should do this on a regular, frequent basis to ensure the validity of your copy of the list. During authentication, the IPsec feature validates the certificate based on the contents of the CRL.

### Syntax:

```
load crl
```

---

## Configuring Manual IP Security (IPv4)

This section describes the configuration options available for manual IPsec with IPv4. All IPsec functions apply to IPv4.

Do the following steps to configure an IPsec manual tunnel:

1. Create the IPsec tunnel.
2. Reset IPsec.
3. Configure policy for the manual tunnel (profile, validity, policy)
4. Reset Policy.

## Configuring the Algorithms

You may configure tunnel policies with the algorithms shown in Table 41.

Table 41. Algorithms Configured with Various Tunnel Policies

Tunnel Policy	Algorithms
AH, AH-ESP, or ESP-AH	<ul style="list-style-type: none"><li>• Local AH Authentication Algorithm—Required</li><li>• Remote AH Authentication Algorithm—Optional</li></ul>

## Configuring Manual IP Security (IPv4)

Table 41. Algorithms Configured with Various Tunnel Policies (continued)

Tunnel Policy	Algorithms
ESP, AH-ESP, or ESP-AH	<ul style="list-style-type: none"><li>Local Encryption Algorithm—Required</li><li>Remote Encryption Algorithm—Optional</li><li>Local ESP Authentication Algorithm—Optional</li><li>Remote ESP Authentication Algorithm—Optional</li></ul> <p><b>Note:</b> If your software load does not include encryption, you will not see encryption-related parameters.</p>

A tunnel policy uses a local algorithm on outbound packets and a remote algorithm on inbound packets. The local algorithm for the router at the near end of a tunnel must match the remote algorithm for the router at the far end of the tunnel. The values for the remote algorithms are optional and they default to the value of the corresponding local algorithms. The local ESP authentication algorithm is optional because ESP authentication is optional.

## Configuring Encryption Keys

For each local algorithm you configure, you must also configure a key that is identical to the key for the corresponding algorithm in the remote host. See the description of keys for the **add tunnel** command at “Manual IP Security Configuration Commands”.

---

## Accessing the IP Security Configuration Environment

To access the IP Security configuration environment, enter **t 6** at the OPCON prompt (\*), then enter the following sequence of commands at the Config> prompt:

```
Config> feature ipsec
IP Security feature user configuration
IPsec config>ipv4
IPV4-IPsec config>
```

---

## Manual IP Security Configuration Commands

This section describes the IP security configuration commands. Enter these commands at the IPV4-IPsec config> prompt.

Table 42. IP Security Configuration Commands Summary

Command	Function
? (Help)	Displays all the commands available for this command level or lists the options for specific commands (if available). See “Getting Help” on page xxxii.
Add tunnel	Adds a secure tunnel.
Change tunnel	Changes a secure tunnel configuration parameter values.
Delete tunnel	Deletes a secure tunnel.
Disable	Disables all IP Security processing in a secure manner (packets that match the packet filters are dropped), disables all IP Security processing in a nonsecure manner (packets that match the packet filters are passed), or disables a secure tunnel.
Enable	Enables all IP Security processing, or enables a secure tunnel.
List	Lists information about global IP Security information, or information about defined tunnels.
Set	Sets various IPSec options.

Table 42. IP Security Configuration Commands Summary (continued)

Command	Function
Exit	Returns you to the previous command level. See “Exiting a Lower Level Environment” on page xxxii.

## Add Tunnel

Use the **add tunnel** command to add the parameters to define an IPsec tunnel.

### Syntax:

**add tunnel...**

#### tunnel-name

Optional parameter to label the tunnel. It must be unique within the 2212.

**Valid values:** up to 15 characters; first character must be a letter; no blanks can be used.

**Default value:** none

#### lifetime

Time in minutes that the tunnel can be active. The value 0 indicates that the tunnel lifetime never expires.

**Valid Values:** 0 - 525600 (0 = no expiration; 525600 = 365 days)

**Default Value:** 46080 (32 days)

#### encapsulation-mode

The manner in which the IP packet is encapsulated. In tunnel mode, the entire IP packet is encapsulated and a new IP header is created; in transport mode, the IP header is not encapsulated. If one end of the secure tunnel is a router, then tunnel mode **must** be used, according to the Internet Engineering Task Force (IETF) security architecture draft.

**Valid Values:** tunnel (*TUNN*) or translate (*TRANS*)

**Default Value:** tunnel (*TUNN*)

#### tunnel-policy

One of the four choices that define the tunnel policy: IP Authentication Header (AH), IP Encapsulating Security Payload (ESP), or combinations of these protocols (AH-ESP and ESP-AH). In AH-ESP, ESP encryption is run first on the outbound packets; in ESP-AH, AH authentication is run first on the outbound packets. Some parameters are unique either to ESP or AH. The encryption parameters are configured only if ESP, AH-ESP, or ESP-AH is selected; the authentication parameters are configured only if AH, AH-ESP, or ESP with authentication is selected.

**Valid Values:** AH, ESP, AH-ESP, ESP-AH

**Default Value:** AH-ESP

#### local-IP-address

IP address for this end of the tunnel.

**Valid Values:** a valid IP address that has been configured either for an interface or as the internal address of the 2212.

**Default Value:** one of the IP addresses configured for the router

#### local-spi

A security association is a one-way security connection that uses AH or ESP to protect connection traffic. The security parameters index (SPI) is an

## Manual IP Security Configuration Commands

arbitrary 32-bit value that uniquely identifies one of the two security associations (inbound or outbound) associated with this secure tunnel. This parameter, which is required, identifies the SPI expected in this tunnel for inbound packets received at the local end of the tunnel. This value cannot match the local SPI of another tunnel with the same local IP address. Regardless of the tunnel policy (ESP, AH, AH-ESP, or ESP-AH), only one local SPI is configured for inbound traffic for one IP secure tunnel.

**Valid Values:** any 32-bit value greater than 255

**Default Value:** 256

### local-encryption-algorithm

The encryption algorithm used for ESP on outbound packets sent from the local router, which is required when configuring ESP. In some countries, some or all of these algorithms may be unavailable because of U.S. export rules. This encryption algorithm must match the remote encryption algorithm.

The ESP-NUL algorithm prevents ESP from performing encryption. This algorithm is available in all countries. If ESP-NUL is selected, ESP must be activated for authentication by selecting one of the authentication algorithms HMAC-MD5 or HMAC-SHA-1.

**Valid Values:** DES-CBC, CDMF, 3DES, or ESP-NUL

**Default Value:** DES-CBC

### local-encryption-key

The key or keys used with the local ESP encryption algorithm. They must match the corresponding keys that are configured in the opposite end of the secure tunnel. This key is not configured when the ESP-NUL encryption algorithm is selected.

**Valid Values:**

- For DES-CBC: 16 hex characters (0 - 9, a - f, A - F)
- For CDMF: 16 hex characters (0 - 9, a - f, A - F)
- For 3DES: three separate keys, none of which is the same, each one 16 hex characters (0 - 9, a - f, A - F)

**Default Value:** none

### padding-for-local-encryption

Size in bytes of additional padding that is added to outbound ESP packets. Additional padding may be used to disguise the size of the IP packets being encrypted when the encryption algorithm results in an encrypted packet that is the same size as the original packet. ESP padding values must be a multiple of 8. If a value that is not divisible by 8 is configured, that value is rounded up to the next value that is divisible by 8.

When the encryption algorithm is ESP-NUL, padding is not necessary because the ESP-NUL algorithm adds one byte to the original packet size. If padding for local encryption is configured, the value is ignored.

**Valid Values:** 0 - 120

**Default Value:** 0

### local-ESP-authentication

Selects local ESP authentication, if desired. Authentication is required if the encryption algorithm is ESP-NUL.

**Valid Values:** Yes or No

## Manual IP Security Configuration Commands

**Default Value:** Yes

### local-authentication-algorithm

The authentication algorithm used on outbound packets. This is an optional parameter for ESP and will not be required unless you select ESP authentication. For AH, AH-ESP, or ESP-AH, this parameter is required. The authentication algorithm used must match the remote authentication algorithm used at the far end of the IPsec tunnel.

**Valid Values:** HMAC-MD5 or HMAC-SHA

**Default Value:** HMAC-MD5

### local-authentication-key

The key used with the local authentication algorithm. It must match the equivalent key that is configured in the opposite end of the IPsec tunnel. It is required if the policy is AH, AH-ESP, or ESP-AH, or if the policy is ESP and the local ESP authentication algorithm has been configured.

**Valid Values:**

- for HMAC-MD5: 32 hex characters (0 - 9, a - f, A - F)
- for HMAC-SHA: 40 hex characters (0 - 9, a - f, A - F)

**Default Value:** none

### remote-IP-address

IP address for the remote end of the tunnel. This is a required parameter.

**Valid Values:** a valid IP address

**Default Value:** none

### remote-spi

A security association is a one-way security connection that uses AH or ESP to protect connection traffic. The security parameters index (SPI) is an arbitrary 32-bit value that uniquely identifies one of the two security associations (inbound or outbound) associated with this secure tunnel. This parameter, which is required, identifies the SPI expected in ESP or AH for outbound packets destined for the remote host. This value cannot match the remote SPI of another tunnel with the same remote IP address. Regardless of the tunnel policy (ESP, AH, AH-ESP, or ESP-AH), only one local SPI is configured for outbound traffic for one IPsec tunnel.

**Valid Values:** any 32-bit value greater than 255

**Default Value:** 256

### remote-encryption-algorithm

The decryption algorithm used on inbound packets received from the remote host. It must match the local encryption algorithm.

The ESP-NUL algorithm prevents ESP from performing encryption. If ESP-NUL is selected, ESP must be activated for authentication by selecting one of the authentication algorithms HMAC-MD5 or HMAC-SHA-1.

**Valid Values:** DES-CBC, CDMF, 3DES, or ESP-NUL

**Default Value:** value of the local encryption algorithm

### remote-encryption-key

The key or keys used with the remote ESP encryption algorithm. They must match the equivalent keys that are configured in the opposite end of the secure tunnel. This key is not configured when the ESP-NUL encryption algorithm is selected.

## Manual IP Security Configuration Commands

### Valid Values:

- For DES-CBC: 16 hex characters (0 - 9, a - f, A - F)
- For CDMF: 16 hex characters (0 - 9, a - f, A - F)
- For 3DES: three separate keys, none of which matches, each 16 characters in hex (0 - 9, a - f, A - F)

**Default Value:** none

### verification-of-remote-encryption-padding

Determines whether the size of the encryption padding on received packets should be verified.

**Valid Values:** Yes or No

**Default Value:** No

### padding-for-remote-encryption

Size in bytes of additional padding that is expected in received ESP packets. This parameter is required and valid only if the value of *verification-of-remote-encryption-padding* is Yes. ESP padding values must be a multiple of 8. If a value that is not divisible by 8 is configured, that value will be rounded up to the next value that is divisible by 8.

**Valid Values:** 0 - 120

**Default Value:** 0

### remote-ESP-authentication

Selects remote ESP authentication for inbound packets, if desired.

**Valid Values:** Yes or No

**Default Value:** Yes

### remote-authentication-algorithm

The authentication algorithm used for inbound packets. This is an optional parameter for ESP and will not be required unless you select ESP authentication. For AH or combinations of AH and ESP (AH-ESP or ESP-AH), this parameter is required. The authentication algorithm used must match the local authentication algorithm used at the far end of the IPsec tunnel.

**Valid Values:** HMAC-MD5 or HMAC-SHA

**Default Value:** HMAC-MD5

### remote-authentication-key

The key used with the remote authentication algorithm. It must match the equivalent key that is configured in the opposite end of the secure tunnel. It is required in AH, AH-ESP and ESP-AH and in ESP if the remote ESP authentication algorithm has been configured.

### Valid Values:

- for HMAC-MD5: 32 hex characters (0 - 9, a - f, A - F)
- for HMAC-SHA: 40 hex characters (0 - 9, a - f, A - F)

**Default Value:** none

### enable-replay-prevention

Specifies whether replay prevention is enabled. If replay prevention is enabled, the sequence numbers in the IP security headers are monitored to prevent duplicate packets from being processed by the tunnel receiver. The use of replay prevention is not recommended because the tunnel security association must be deactivated when a sender's sequence number counter



## Manual IP Security Configuration Commands

reaches its limit. When this happens, manual intervention is required to restart the existing security association or create a new one.

In addition, if replay prevention is enabled and you reset IPsec using the **reset ipsec** command, you must make sure that IPsec is also reset on the router at the other end of the IPsec tunnel. This is necessary to re-initialize the sequence number at both ends of the tunnel. If IPsec is reset on one end of the tunnel and not on the other, it is possible that routers at each end of the tunnel will drop packets due to sequence number mismatch.

**Valid Values:** Yes or No

**Default Value:** No

**DF-bit** Specifies the handling of the Don't Fragment (DF) bit in the outer header for tunnel mode secure tunnels. This bit can be set in IPv4 headings to specify that the packet cannot be fragmented. The DF-bit parameter tells the 2212 how it should handle the DF bit on incoming packets - whether to copy the value of the DF-bit found in the inner header to the outer header, or whether to set or clear the bit in the outer header.

If the DF bit is set and the packet cannot be fragmented, IPsec uses the Path MTU (PMTU) Discovery function. See "Path Maximum Transmission Unit Discovery" on page 348 for more information.

**Valid Values:** Copy, Set, Clear

**Default Value:** Copy

### **enable-tunnel**

Specifies whether this tunnel is enabled. The enabled tunnel will not filter packets until a packet filter has been configured to define the interface over which this IPsec tunnel will operate and IP has been reset or restarted on the 2212. You can use the **reset ip** command to reset IP.

**Valid Values:** Yes or No

**Default Value:** Yes

## Change Tunnel

Use the **change tunnel** command to change an IPsec tunnel parameter previously configured by the **add tunnel** command.

### **Syntax:**

**change tunnel...** See the **add tunnel** command for a list of the parameters that can be changed.

## Delete Tunnel

Use the Talk 6 **delete tunnel** command to delete an IPsec tunnel.

### **Syntax:**

**delete tunnel** *tunnel-id*  
*tunnel-name*  
*all*

### **tunnel-id**

Specifies the identifier of the IPsec tunnel to be deleted.

**Valid Values:** 1 - 65535

**Default Value:** 1

## Manual IP Security Configuration Commands

### tunnel-name

Specifies the name of the IPsec tunnel to be deleted.

**Valid Values:** any configured tunnel name

**Default Value:** none

**all** Specifies that all IPsec tunnels on this interface are to be deleted.

## Disable

Use the **disable** command to disable the IPsec tunnel or to disable all IPsec tunnels either in a secure manner (packets that match the IPsec filters are dropped) or an insecure manner (packets that match the IPsec filters are passed).

### Syntax:

```
disable                ipsec drop
                        ipsec pass
                        tunnel ...
```

### ipsec drop

Disables IP security on the router in a secure manner. All IPsec tunnels will be disabled, but the secure tunnel information in packet filter rules is used to identify packets that match IPsec tunnel packet filters. The matching packets are dropped.

### ipsec pass

Disables IP security on the router in a non-secure manner. All IPsec tunnels will be disabled. Packets that match IPsec tunnel packet filters are forwarded as ordinary traffic.

### tunnel *tunnel-id tunnel-name all*

Disables IP security on a specified tunnel or on all tunnels.

#### tunnel-id

Specifies the identifier of the secure tunnel to be disabled.

**Valid Values:** 1 - 65535

**Default Value:** 1

#### tunnel-name

Specifies the name of the secure tunnel to be disabled.

**Valid Values:** any configured tunnel name

**Default Value:** none

**all** All tunnels.

## Enable

Use the **enable** command to enable the IP Security protocol on all interfaces or a single tunnel. You must enable IPsec globally on the router before the individually enabled IPsec tunnels become active.

### Syntax:

```
enable                ipsec
                        tunnel ...
```

**ipsec** Enables IP security throughout the router.

### tunnel *tunnel-id tunnel-name all*

Enables IP security on a specified tunnel or on all tunnels.

## Manual IP Security Configuration Commands

### tunnel-id

Specifies the identifier of the secure tunnel to be enabled.

**Valid Values:** 1 - 65535

**Default Value:** 1

### tunnel-name

Specifies the name of the secure tunnel to be enabled.

**Valid Values:** any configured tunnel name

**Default Value:** none

**all** All tunnels.

## List

Use the **list** command to display the current IP Security configuration. Global tunnels include all tunnels in the router, both active and defined. All tunnels include all tunnels configured on this interface, both active and defined. Active tunnels are those that are currently active; defined tunnels are defined but not active. For IPv4, the selected certificates in a router's SRAM are also listed.

### Syntax:

```
list ...                all
                        status
                        tunnel
                        active tunnel-id tunnel-name all
                        defined tunnel-id tunnel-name all
```

### Example 1: Listing all IPsec tunnels

```
IPsec config>list all
```

IPsec is ENABLED

IPsec Path MTU Aging Timer is 20 minutes

Defined Manual Tunnels:

ID	Name	Local IP Addr	Remote IP Addr	Mode	State
1	test	1.1.1.1	2.1.1.1	TUNN	Enabled
2	test2	1.1.1.1	1.1.1.3	TRANS	Enabled

Tunnel Cache:

ID	Local IP Addr	Remote IP Addr	Mode	Policy	Tunnel Expiration
2	1.1.1.1	1.1.1.3	TRANS	ESP	*****
1	1.1.1.1	2.1.1.1	TUNN	AH	*****

### Example 2: Listing an IPsec tunnel with the ESP policy and the ESP-NULL algorithm

```
IPsec config>ti tun 1000
```

Tunnel ID	Name	Mode	Policy	Life	Replay Prev	Rcv Win	IPsec Vers	State
1000	t1000	TUNN	ESP	46080	No	---	V2	Enabled

Handling of DF bit in outer header: COPY

Local Information:

## Manual IP Security Configuration Commands

```
IP Address: 10.11.12.10
Authentication: SPI: -----
Encryption: SPI: 1234
Remote Information:
IP Address: 10.11.12.11
Authentication: SPI: -----
Encryption: SPI: 1234
Algorithm: -----
Encryption Algorithm: NULL
Extra Pad: 0
ESP Authentication Algorithm: HMAC-MD5
Algorithm: -----
Encryption Algorithm: NULL
Verify Pad?: No
ESP Authentication Algorithm: HMAC-MD5
```

## Set

Use the **set** command to control the tunnel PMTU value.

### Syntax:

```
set path-mtu-age-timer
```

### **path-mtu-age-timer**

Specifies the time (in minutes) that will elapse before the 2212 restores the tunnel PMTU value to the maximum.

**Default Value:** 10 (0 means disabled)

---

## Configuring a Manual Tunnel (IPv4)

This topic provides information about configuring a manual IPv4 tunnel for the network shown in Figure 38 on page 350.

## Configuring the Tunnel for Router A

The following example shows how to configure an IPsec manual tunnel for router A in the network shown in Figure 38 on page 350 using IPv4.

```
Config> feature ipsec
IP Security feature user configuration
IPsec config>ipv4
IPV4-IPsec config>add tunnel
Adding tunnel 1
Tunnel Name (optional)? tunnelone
Tunnel Lifetime, in minutes (0-525600) [46080]?
Tunnel Encapsulation Mode (TUNN or TRANS) [TUNN]?
Tunnel Policy (AH, ESP, AH-ESP, ESP-AH) [AH-ESP]? AH
Local IP Address [1.1.1.1]? 223.252.252.216
Local Authentication SPI (256-65535) [256]?
Local Authentication Algorithm (HMAC-MD5, HMAC-SHA) [HMAC-MD5]?
Local Authentication Key (32 characters) in Hex (0-9,a-f,A-F):
Enter Local Authentication Key again (32 characters) in Hex (0-9,a-f,A-F):
Remote IP Address [0.0.0.0]? 223.252.252.210
Remote Authentication SPI (1-65535) [256]?
Remote Authentication Algorithm (HMAC-MD5, HMAC-SHA) [HMAC-MD5]?
Remote Authentication Key (32 characters) in Hex (0-9,a-f,A-F):
Enter Remote Authentication Key again (32 characters) in Hex (0-9,a-f,A-F):
Enable replay prevention? [No]:
Copy, set, or clear DF bit in outer header (COPY,SET,CLEAR) [COPY]?
Do you wish to enable this tunnel? [Yes]:
IPV4-IPsec config>
```

As you can see from this example, you are prompted for the parameters that you need to provide. The configuration of an ESP, AH-ESP, or ESP-AH secure tunnel calls for similar parameters.

## Configuring a Manual Tunnel (IPv4)

**Note:** The values of the keys are not displayed when they are entered. Therefore, they are not visible in this example. If the keys for HMAC-MD5 authentication were visible, you would see 32 hexadecimal characters. For example, a key could have the value: X'1234567890ABCDEF1234567890ABCDEF'.

## Configuring the Tunnel for Router B

Within router B, you must configure the same IPsec manual tunnel that was configured for router A, IPsec tunnel 1. The local IP address of this tunnel in router B is 223.252.252.210 and the remote IP address is 223.252.252.216. All other IPsec tunnel parameters must match the parameters that were configured for router A.

## Example: Manually Configuring an IP Security Tunnel with ESP

Note that you are prompted to set the DF bit when the tunnel is in tunnel mode and the tunnel policy is ESP. This example shows only the configuration of the IPsec tunnel, not of the packet filters.

```
IPV4-IPsec config>add tunnel
Adding tunnel 2
Tunnel Name (optional)? tunneltwo
Tunnel Lifetime, in minutes (0-525600) [46080]?
Tunnel Encapsulation Mode (TUNN or TRANS) [TUNN]?
Tunnel Policy (AH,ESP,AH-ESP,ESP-AH) [AH-ESP]? ESP
Local IP Address [1.1.1.1]?
Local Encryption SPI (256-65535) [256]?
Local Encryption Algorithm (DES-CBC,CDMF,3DES, NULL) [DES-CBC]?
Do you wish to change the Local Encryption Key? [No]:
Additional Padding for Local Encryption (0-120) [0]?
Do you wish to use local ESP authentication? [Yes]:
Remote IP Address [0.0.0.0]?
Remote Encryption SPI (1-65535) [256]?
Remote Encryption Algorithm (DES-CBC,CDMF) [DES-CBC]?
Do you wish to change the Remote Encryption Key? [No]:
Do you wish to perform verification of remote encryption padding? [No]:
Do you wish to use remote ESP authentication? [No]:
Copy, set or clear DF bit in outer header (COPY,SET,CLEAR) [COPY]?
Do you wish to enable this tunnel? [Yes]:
IPV4-IPsec config>
```

## Example: Manually Configuring an IP Security Tunnel with ESP and ESP-NULL

Note that authentication is required.

```
IPV4-IPsec config>add tunnel
Adding tunnel 3
Tunnel Name (optional)? tunnel3
Tunnel Lifetime, in minutes (0-525600) [46080]?
Tunnel Encapsulation Mode (TUNN or TRANS) [TUNN]?
Tunnel Policy (AH,ESP,AH-ESP,ESP-AH) [AH-ESP]? ESP
Local IP Address [1.1.1.1]?
Local Encryption SPI (256-65535) [256]? 1234
Local Encryption Algorithm (DES-CBC,CDMF,3DES,NULL) [DES-CBC]? null
Additional Padding for Local Encryption (0-120) [0]?
Local ESP Authentication Algorithm (HMAC-MD5,HMAC-SHA) [HMAC-MD5]?
Local ESP Authentication Key (32 characters) in Hex (0-9,a-f,A-F):
Enter Local ESP Authentication Key again (32 characters) in Hex (0-9,a-f,A-F):
Remote IP Address [0.0.0.0]? 10.11.12.11
Remote Encryption SPI (1-65535) [1234]?
Remote Encryption Algorithm (DES-CBC,CDMF,3DES,NULL) [NULL]?
Do you wish to perform verification of remote encryption padding? [No]:
Remote ESP Authentication Algorithm (HMAC-MD5,HMAC-SHA) [HMAC-MD5]?
Remote ESP Authentication Key (32 characters) in Hex (0-9,a-f,A-F):
Enter Remote ESP Authentication Key again (32 characters) in Hex (0-9,a-f,A-F):
Enable replay prevention? [No]:
Copy, set or clear DF bit in outer header (COPY,SET,CLEAR) [COPY]?
Do you wish to enable this tunnel? [Yes]:
IPV4-IPsec config>
```

### Configuring Manual IP Security (IPv6)

This section describes the configuration options available for manual IPsec with IPv6. All IPsec functions apply to IPv6. Observe the following changes to the IPsec configuration questions when you are configuring IPsec for IPv6:

- Enter addresses in IPv6 address format (for example, 8:0:9:8::1).
- You are not asked for the DF bit setting.

Do the following steps to configure an IPsec manual tunnel:

1. Create the IPsec tunnel.
2. Reset IPsec.
3. Configure filter rules.
4. Reset IPV6.

### Configuring the Algorithms

You may configure tunnel policies with the algorithms shown in Table 43.

Table 43. Algorithms Configured with Various Tunnel Policies

Tunnel Policy	Algorithms
AH, AH-ESP, or ESP-AH	<ul style="list-style-type: none"><li>• Local AH Authentication Algorithm—Required</li><li>• Remote AH Authentication Algorithm—Optional</li></ul>
ESP, AH-ESP, or ESP-AH	<ul style="list-style-type: none"><li>• Local Encryption Algorithm—Required</li><li>• Remote Encryption Algorithm—Optional</li><li>• Local ESP Authentication Algorithm—Optional</li><li>• Remote ESP Authentication Algorithm—Optional</li></ul> <p><b>Note:</b> If your software load does not include encryption, you will not see encryption-related parameters.</p>

A tunnel policy uses a local algorithm on outbound packets and a remote algorithm on inbound packets. The local algorithm for the router at the near end of a tunnel must match the remote algorithm for the router at the far end of the tunnel. The values for the remote algorithms are optional and they default to the value of the corresponding local algorithms. The local ESP authentication algorithm is optional because ESP authentication is optional.

### Configuring Encryption Keys

For each algorithm you configure, you must also configure a key that is identical to the key for the corresponding algorithm in the remote host. See the description of keys for the **add tunnel** command at “Manual IP Security Configuration Commands” on page 362.

### Accessing the IP Security Configuration Environment

To access the IP Security configuration environment, enter **t 6** at the OPCON prompt (\*), then enter the following sequence of commands at the Config> prompt:

```
Config> feature ipsec
IP Security feature user configuration
IPsec config> ipv6
IPV6-IPsec config>
```

## Manual IP Security Configuration Commands

See “Manual IP Security Configuration Commands” on page 362 for a description of the IP Security configuration commands available for IPv6. The commands for IPv6 are the same as those used for IPv4 unless indicated otherwise. Enter the commands at the IPV6-IPsec config> prompt.

### Configuring a Manual Tunnel (IPv6)

Refer to the example network in Figure 38 on page 350 while reading this topic. IPsec tunnel 1 has an endpoint on interface 1 in router A. Router A will be configured for IPsec. Do the following steps to configure router A manually:

1. Create the IPsec tunnel.
2. Create one outbound packet filter on the router interface that is the endpoint of the IPsec tunnel.
3. Create access control rules for the packet filters.
4. Reset IPsec.
5. Reset IPv6.

### Creating the IP Security Tunnel for Router A

The following example shows how to create IPsec tunnel 1 for router A. The following example shows how to create IPsec tunnel 1 for router A.

```
Config> feature ipsec
IP Security feature user configuration
IPsec config> ipv6
IPV6-IPsec config> add tunnel
IPsec Tunnel ID (1 - 65535) [1]
Tunnel Name (optional)? tunnelone
Tunnel Lifetime, in minutes (0-525600) [46080]?
Tunnel Encapsulation Mode (TUNN or TRANS) [TUNN]?
Tunnel Policy (AH, ESP, AH-ESP, ESP-AH) [AH-ESP]? AH
Local IP Address [1000:1::1]? 2000::A
Local Authentication SPI (256-65535) [256]?
Local Authentication Algorithm (HMAC-MD5, HMAC-SHA) [HMAC-MD5]?
Local Authentication Key (32 characters) in Hex (0-9,a-f,A-F):
Enter Local Authentication Key again (32 characters) in Hex (0-9,a-f,A-F):
Remote IP Address [0::0]? 2000::B
Remote Authentication SPI (1-65535) [256]?
Remote Authentication Algorithm (HMAC-MD5, HMAC-SHA) [HMAC-MD5]?
Remote Authentication Key (32 characters) in Hex (0-9,a-f,A-F):
Enter Remote Authentication Key again (32 characters) in Hex (0-9,a-f,A-F):
Enable replay prevention? [No]:
Do you wish to enable this tunnel? [Yes]:
IPV6-IPsec config>
```

As you can see from this example, you are prompted for the parameters that you need to provide. The configuration of an ESP, AH-ESP, or ESP-AH secure tunnel calls for similar parameters.

**Note:** The values of the keys are not displayed when they are entered. Therefore, they are not visible in this example. If the keys for HMAC-MD5 authentication were visible, you would see 32 hex characters. For example, a key could have a value such as X'1234567890ABCDEF1234567890ABCDEF'.

### Configuring Packet Filters for Router A

After you have created the IPsec tunnel for router A, you must set up one IP packet filter. The creation of the packet filter *out-router-A* is shown in the following example. Refer to the sections IPv6 Filtering and Access Control in the chapter Using IPv6 in *Protocol Configuration and Monitoring Reference Volume 1* for more information about configuring IPv6 packet filters and access control rules.

## Configuring a Manual Tunnel (IPv6)

```
*talk 6
Config> Protocol IPv6
Internet protocol user configuration
IPv6 Config> set access-control on
IPv6 Config> add packet-filter
Packet-filter name [ ]? out-router-A
Filter incoming or outgoing traffic? [IN]? OUT
Which interface is this filter for [0]? 1
IPv6 Config> update packet-filter
Packet-filter name [ ]? out-router-A
Packet-filter 'out-router-A' Config>
```

## Configuring Packet Filter Access Control Rules for Router A

The next step is to configure the packet filter access control rules. Create two access control rules on the outbound packet filter *out-router-A*.

The access control rules on the outbound packet filter perform these functions:

- One access control rule defines the range of the source and destination addresses of the packets to be passed into the IPSec tunnel.
- The other access control rule allows IPSec traffic to pass through the packet filter.

Configure the first access control rule for packet filter *out-router-A*. This access control rule passes packets from network 1000:1:: to the destination network 3000:1:: attached to Router B.

```
IPv6 Config> update packet-filter
Packet-filter name [ ]? out-router-A
Packet-filter 'out-router-A' Config> add access
Enter type [E]? IS
Internet source [0::0]? 1000:1::
Prefix Length [64]? 64
Internet destination [0::0]? 3000:1::
Prefix Length [64]? 64
Enter IPsec Tunnel ID [1]? 2
Packet-filter 'out-router-A' Config>
```

The second access control rule for *out-router-A* allows secured packets to pass between the two ends of the IPSec tunnel.

```
Packet-filter 'out-router-A' Config> add access
Enter type [E]? I
Internet source [0::0]? 2000::A
Prefix Length [64]? 64
Internet destination [0::0]? 2000::B
Prefix Length [64]? 64
Packet-filter 'out-router-A' Config>
```

As with the other packet filters, you may want to configure a wildcard access control rule for *out-router-A* to pass traffic that does not match any access control rules.

## Resetting IP Security and IP on Router A

After you finish configuring the policy, use the Talk 5 **reset ipsec** command to reload SRAM with the new IPSec configuration. The **reset ipsec** command does not affect any IP configuration. Then, use the Talk 5 **reset ipv6** command to dynamically reset IPv6 within the router. Alternatively, to reset each component, you can restart the router. You must either reset IPSec and IPv6 or restart the router to ensure that the filter rules are reloaded. Otherwise, your configuration may not be correctly supported on the interface. See “Chapter 21. Configuring and Monitoring



## Configuring a Manual Tunnel (IPv6)

IP Security” on page 357 and the **reset ipv6** command in *Protocol Configuration and Monitoring Reference Volume 2* for more information.

As shown in Figure 38 on page 350, IPsec tunnel 2 has an endpoint on interface 1 in Router B. Do the following steps to configure router B manually.

1. Create the IPsec tunnel.
2. Create one outbound filter on the router interface that is the endpoint of the IPsec tunnel.
3. Create access control rules for the packet filters.
4. Reset IPsec.
5. Reset IPv6.

## Creating the IP Security Tunnel for Router B

Within router B, the same IPsec tunnel that was created for router A, IPsec tunnel 2, must be created. The local IP address of this tunnel in router B is 2000::B and the remote IP address is 2000::A. All other IPsec tunnel parameters must match the parameters that were specified for router A.

## Configuring Packet Filters for Router B

As you did for router A, configure an outbound packet filter (*out-router-B*) on interface 1, which is the interface in router B that is the endpoint of IPsec tunnel 1.

## Configuring Packet-Filter Access Control Rules for Router B

Configure an access control rule on *out-router-B* to pass outbound packets from network 3000:1:: to IPsec for processing and transmission through IPsec tunnel 2. This access control rule is type I and S.

```
Packet-filter name [ ]? out-router-B
Packet-filter 'out-router-B' Config> add access
Enter type [E]? IS
Internet source [0::0]? 3000:1::
Prefix Length [64]? 64
Internet destination [0::0]? 1000:1::
Prefix Length [64]? 64
Enter IPsec Tunnel ID [1]? 2
Packet-filter 'out-router-B' Config>
```

Now, for *out-router-B*, create an inclusive access control rule to let packets that have been processed by IPsec pass through IPsec tunnel 2.

```
Packet-filter 'out-router-B' Config> add access
Enter type [E]? I
Internet source [0::0]? 2000::B
Prefix Length [64]? 64
Internet destination [0::0]? 2000::A
Prefix Length [64]? 64
Packet-filter 'out-router-B' Config>
```

For *out-router-B*, create an inclusive wildcard access control rule if you wish to pass rather than drop packets that do not match either of the two access control rules, for example, traffic not destined for IPsec tunnel 2.

## Resetting IP Security and IPv6 on Router B

Before the IPsec function will work and the filters are activated, you must reset IPsec and IPv6. Use the talk 5 **reset IPsec** command to reset IPsec and IPv6. See “Resetting IP Security and IP on Router A” on page 374 for information about

## Configuring a Manual Tunnel (IPv6)

resetting IPsec. After you reset IPsec, use the talk 5 **reset IPv6** command to reset IPv6. Alternatively, to reset each component, you can restart the router.

## Example: Configuring an IP Security Tunnel with ESP

Note that this example shows only the configuration of the IPsec tunnel, not of the packet filters.

```
IPV6-IPsec config>add tun
Tunnel ID or Tunnel Name [ ]? 2
Tunnel Lifetime, in minutes (0-525600) [46080]?
Tunnel Encapsulation Mode (TUNN or TRANS) [TUNN]?
Tunnel Policy (AH,ESP,AH-ESP,ESP-AH) [ESP]?
Local IP Address [0::0]? 2000::A
Local Encryption SPI (256-65535) [256]?
Local Encryption Algorithm (DES-CBC,CDMF,3DES, NULL) [DES-CBC]?
Do you wish to change the Local Encryption Key? (Yes or [No]):
Additional Padding for Local Encryption (0-120) [0]?
Do you wish to use local ESP authentication? [Yes]:
Remote IP Address [0::0]? 2000::B
Remote Encryption SPI (1-65535) [256]?
Remote Encryption Algorithm (DES-CBC,CDMF) [DES-CBC]?
Do you wish to change the Remote Encryption Key? (Yes or [No]):
Do you wish to perform verification of remote encryption padding? [No]:
Do you wish to use remote ESP authentication? [No][No]:
Do you wish to enable this tunnel? [Yes]:
IPV6-IPsec config>
```

## Example: Configuring an IP Security Tunnel with ESP and ESP-NULL

Note that authentication is required.

```
IPV6-IPsec config>add tun
Tunnel ID or Tunnel Name [ ]? 2
Tunnel Lifetime, in minutes (0-525600) [46080]?
Tunnel Encapsulation Mode (TUNN or TRANS) [TUNN]?
Tunnel Policy (AH,ESP,AH-ESP,ESP-AH) [ESP]?
Local IP Address [0::0]? 2000::A
Local Encryption SPI (256-65535) [256]?
Local Encryption Algorithm (DES-CBC,CDMF,3DES,NULL) [DES-CBC]? null
Additional Padding for Local Encryption (0-120) [0]?
Local ESP Authentication Algorithm (HMAC-MD5,HMAC-SHA) [HMAC-MD5]?
Local ESP Authentication Key (32 characters) in Hex (0-9,a-f,A-F):
Enter Local ESP Authentication Key again (32 characters) in Hex (0-9,a-f,A-F):
Remote IP Address [0::0]? 2000::B
Remote Encryption SPI (1-65535) [1234]?
Remote Encryption Algorithm (DES-CBC,CDMF,3DES,NULL) [NULL]?
Do you wish to perform verification of remote encryption padding? [No]:
Remote ESP Authentication Algorithm (HMAC-MD5,HMAC-SHA) [HMAC-MD5]?
Remote ESP Authentication Key (32 characters) in Hex (0-9,a-f,A-F):
Enter Remote ESP Authentication Key again (32 characters) in Hex (0-9,a-f,A-F):
Enable replay prevention? [No]:
Do you wish to enable this tunnel? [Yes]:
IPV6-IPsec config>
```

---

## Monitoring Manual IP Security (IPv4)

This section explains how to monitor manual IPsec with IPv4. It describes how to access the Internet Key Exchange environment and the available commands.

## Accessing the Internet Key Exchange Environment

This section explains how to use the Internet Key Protocol (IKE) with IPv4.

To access the IP Security IKE monitoring environment, enter the following sequence of commands at the **+** prompt:

## Accessing the Internet Key Exchange Environment (IPv4)

```
+ feature ipsec
IPSP>ike
IKE>
```

### Internet Key Exchange Monitoring Commands

This section describes the IKE monitoring commands.

Table 44. IKE Monitoring Commands Summary

Command	Function
? (Help)	Displays all the commands available for this command level or lists the options for specific commands (if available). See “Getting Help” on page xxxii.
Delete	Dynamically deletes a specific tunnel’s ISAKMP Phase 1 SAs, or all Phase 1 SAs.
List	Lists information about a specific tunnel’s Phase 1 SAs or all Phase 1 SAs.
Stats	Displays statistics for a tunnel.
Exit	Returns you to the previous command level. See “Exiting a Lower Level Environment” on page xxxii.

#### Delete

Use the IKE **delete** command to dynamically delete a Phase 1 SA for a tunnel or all Phase 1 SAs.

#### Syntax:

```
delete                tunnel
                        all
```

**tunnel** Specifies that a Phase 1 SA is to be deleted for a specific tunnel.

**all** Specifies that all Phase 1 SAs are to be deleted.

#### Example: Deleting a Tunnel

```
PKI config>delete tunnel
Peer address [10.0.0.3]?
```

#### List

Use the IKE **list** command to display information about a specific tunnel’s Phase 1 SAs, or all SAs.

#### Syntax:

```
list                  tunnel
                        all
```

**tunnel** Specifies that information is to be displayed for a specific tunnel’s SAs.

**all** Specifies that information is to be displayed for all SAs.

#### Example: Listing Information for all SAs

```
IKE>list all
```

```
Phase 1 ISAKMP Tunnels for IPv4:
-----
Peer Address   I/R  Mode  Auto  State      Auth
-----
      10.0.0.3   R   Aggr  N     QM_IDLE    pre-shared
```

```
IKE>list tunnel 10.0.0.3
```

## IKE Monitoring Commands (Talk 5)

```
Peer IKE address: 10.0.0.3
Local IKE address: 10.0.0.1
Role: Responder
Exchange: Aggr
Autostart: No
Oakley State: QM_IDLE
Authentication Method: Pre-shared Key
Encryption algorithm: des3
Hash function: md5
Diffie-Hellman group: 1
Refresh threshold: 85
Lifetime (secs): 15000
```

### Stats

Use the IKE **stats** command to display tunnel statistics.

### Syntax:

```
stats tunnel
```

*tunnel* Displays statistical information about a tunnel's SAs.

**Valid Values:** any configured tunnel-name or tunnel-id.

### Example: Displaying a Tunnel's SA Statistics

```
IKE>stats
```

```
Peer address [10.0.0.3]?
```

```
Peer IP address.....: 10.0.0.3
Active time (secs)...: 187

In          Out
---          ---
Octets.....: 1229      1248
Packets.....: 14        16
Drop pkts...: 0         1
Notifys.....: 6         0
Deletes.....: 0         0
Phase 2 Proposals....: 16       18
Invalid Proposals....: 0
Rejected Proposals...: 0
```

## Accessing the Public Key Infrastructure Environment (IPv4)

This section explains how to use the Public Key Infrastructure (PKI) with IPv4.

To access the IP Security PKI monitoring environment, enter the following sequence of commands at the **+** prompt:

```
+ feature ipsec
IPSP>pki
PKI>
```

## Public Key Infrastructure Monitoring Commands

This section describes the Public Key Infrastructure (PKI) monitoring commands.

Table 45. PKI Monitoring Commands Summary

Command	Function
? (Help)	Displays all the commands available for this command level or lists the options for specific commands (if available). See "Getting Help" on page xxxii.
Cert-load	Loads a certificate into a router's SRAM.
Cert-req	Submits a certificate request to a CA.

Table 45. PKI Monitoring Commands Summary (continued)

Command	Function
Cert-save	Saves a certificate into cache for possible future use.
List certificate	Lists information about a certificate.
List configured-servers	Displays information about the configured servers.
Load certificate	Loads a record containing the certificate from SRAM into the run time cache.
Exit	Returns you to the previous command level. See "Exiting a Lower Level Environment" on page xxxii.

### Cert-load

Use the PKI **cert-load** command to load a record containing the certificate and private key from SRAM into the run time certificate cache.

#### Syntax:

**cert-load**

#### Example: Loading a Certificate Record from SRAM into Cache

```
Enter type of certificate to be stored into SRAM:
  1)Root certificate;
  2)Box certificate with private key;
Select the certificate type (1-2) [2]?
Name []? test
mystr=1.1.1.1
Box certificate and private key saved into cache successfully
```

### Cert-req

Use the PKI **cert-req** command to request a certificate from a CA.

#### Syntax:

**cert-req**

#### Example: Requesting a Certificate from a CA

```
Enter the following part for the subject name
Country Name(Max 16 characters) []? us
Organization Name(Max 32 characters) []? ibm
Organization Unit Name(Max 32 characters) []? nhd
Common Name(Max 32 characters) []?
Key modulus size (512|768|1024)
[512]?
Certificate subject-alt-name type:
  1--IPv4 Address
  2--User FQDN
  3--FQDN
Select choice [1]?
Enter an IPv4 addr) []? 1.1.1.1
Generating a key pair. This may take some time. Please wait ...
PKCS10 message successfully generated
Enter tftp server IP Address []? test
Bad address, try again
Enter tftp server IP Address []? 8.8.8.8
Remote file name (max 63 chars) [/tmp/tftp_pkcs10_file]?
Certificate request TFTP to remote host successfully.
```

### Cert-save

Use the PKI **cert-save** command to save a record containing the certificate and private key into SRAM.

#### Syntax:

**cert-save**

## PKI Monitoring Commands (Talk 5)

### Example: Saving a Certificate Record into SRAM

```
Enter type of certificate to be stored into SRAM:
  1)Root certificate;
  2)Box certificate with private key;
Select the certificate type (1-2) [2]?
SRAM Name for certificate and private key []? test
Load as default router certificate at initialization? [No]:
Private key TEST written into SRAM
Both Certificate and private key saved into SRAM successfully
```

### List Certificate

Use the PKI **list certificate** command to display information about an X.509 digital certificate.

#### Syntax:

**list certificate**

### Example: Listing certificate information

```
Router certificate
Serial Number: 914034877
Subject Name: /c=US/o=ibm/ou=nhd/cn=testip
Issuer Name: /c=US/o=ibm/ou=nhd
Subject alt Name: 1.1.1.1
Key Usage: Sign & Encipherment
Validity: 1999/1/19 23:24:27 -- 2002/1/19 23:54:27
```

### List Configured-servers

Use the PKI **list configured-servers** command to display information about the configured servers.

#### Syntax:

**list configured-servers**

### Example: Listing Information about Configured Servers

```
1) Name: SERVER1
   Type: LDAP
   IP addr: 0.0.0.0
      LDAP search timeout (secs): 0
      LDAP retry interval (mins): 0
      LDAP server port number: 0
      LDAP version: 0
      LDAP version: 0
      Anonymous bind ?: y

2) Name: TEST
   Type: TFTP
   IP addr: 9.9.9.9

3) Name: TFTP
   Type: TFTP
   IP addr: 2.2.2.2
```

### Load Certificate

Use the PKI **load certificate** command to load a certificate from SRAM into the run time cache.

#### Syntax:

**load certificate**

**Example: Loading a Certificate into Cache**

```

Enter the type of the certificate:
Choices: 1-Root CA Cert, 2-Router Cert
Enter (1-2): [2]?
Encoding format:
Choices: 1-DER 2-PEM
Enter (1-2): [1]?
Server info name []? test
Remote file name on tftp server (max 63 chars) [/tmp/default_file]? /tmp/test.cert

Attempting to load certificate file. Please wait ...
Router Certificate loaded into run-time cache
    
```

**Accessing the IP Security Monitoring Environment (IPv4)**

To access the IPv4 IP Security monitoring environment type **t 5** at the OPCON prompt (\*):

```
* t 5
```

Then, enter the following sequence of commands at the **+** prompt:

```

+ feature ipsec
IPSP>ipv4
IPV4-IPsec>
    
```

**IP Security Monitoring Commands (IPv4)**

This section describes the IP Security monitoring commands.

*Table 46. IP Security Monitoring Commands Summary*

Command	Function
? (Help)	Displays all the commands available for this command level or lists the options for specific commands (if available). See “Getting Help” on page xxxii.
Change tunnel	Dynamically changes a secure tunnel configuration parameter values.
Delete tunnel	Dynamically deletes a secure tunnel.
Disable	Dynamically disables all IP Security processing in a secure manner (matching packets are dropped), disables all IP Security processing in a nonsecure manner (matching packets are forwarded), or disables a particular secure tunnel.
Enable	Dynamically enables all IP Security processing, or enables a secure tunnel.
Itp	IP Security tunnel ping. Determines whether the party at the far end of an IPSec tunnel can be contacted.
List	Lists global information about IP Security, about active and defined tunnels.
Reset	Resets IP Security or resets a secure tunnel. This command reloads the configuration that was created in Talk 6. Resetting will override the values of parameters configured using Talk 5 with those that were configured using Talk 6.
Set	Dynamically sets the Path MTU (PMTU) aging timer.
Stats	Displays statistics for all tunnels or for an active tunnel.
Exit	Returns you to the previous command level. See “Exiting a Lower Level Environment” on page xxxii.

**Change Tunnel**

Dynamically changes a secure tunnel.

**Syntax:**

**change tunnel ...**

## IP Security Monitoring Commands (Talk 5)

See the description of the **add tunnel** command under “Manual IP Security Configuration Commands” on page 362 for a description of the parameters.

### Delete Tunnel

Use the **delete** command to dynamically delete a secure tunnel or all secure tunnels.

#### Syntax:

**delete tunnel**

*tunnel-id*

*tunnel-name*

**all**

#### tunnel-id

Specifies the identifier of the IPsec tunnel to be deleted.

**Valid Values:** 1 - 65535

**Default Value:** 1

#### tunnel-name

Specifies the name of the IPsec tunnel to be deleted.

**Valid Values:** any configured tunnel name

**Default Value:** none

**all** Specifies that all IPsec tunnels on this interface are to be deleted.

### Disable

Use the **disable** command to dynamically disable the IP Security protocol on all interfaces or a single tunnel.

#### Syntax:

**disable**

*ipsec drop*

*ipsec pass*

*tunnel ...*

#### ipsec drop

Disables IP security on the router in a secure manner. All IPsec tunnels will be disabled, but the secure tunnel information in packet filter rules is used to identify packets that match IPsec tunnel packet filters. The matching packets are dropped.

#### ipsec pass

Disables IP security on the router in a non-secure manner. All IPsec tunnels will be disabled. Packets that match IPsec tunnel packet filters are forwarded as ordinary traffic.

#### tunnel *tunnel-id* **all**

Disables IP security on a specified tunnel or on all tunnels.

#### tunnel-id

Specifies the identifier of the secure tunnel to be disabled.

**Valid Values:** 1 - 65535

**Default Value:** 1

**all** All tunnels.



## IP Security Monitoring Commands (Talk 5)

### Enable

Use the **enable** command to dynamically enable the IP Security protocol on all interfaces or a single tunnel. You must enable IPsec globally on the router before the individually enabled IPsec tunnels become active.

**Note:** IPsec cannot be dynamically enabled if the router was restarted with IPsec disabled.

#### Syntax:

```
enable                ipsec
                        tunnel ...
```

**ipsec** Enables IP security throughout the router.

**tunnel** *tunnel-id* | **all**

#### tunnel-id

Specifies the identifier of the secure tunnel to be enabled.

**Valid Values:** 1 - 65535

**Default Value:** 1

**all** All tunnels.

### Itp

Use the **itp** command (IPsec tunnel ping) to create and send a special IP packet over an IPsec tunnel, which verifies that the router at the far end of the tunnel can respond by returning the packet. The packet is sent repeatedly at the frequency specified by the rate argument until you terminate the command by pressing **Enter**. When you press **Enter**, itp prints its status for all packets that it has sent.

**Note:** The **itp** command works only for tunnels that are operating in tunnel mode. Also, the other router must have IP forwarding capability and be enabled.

#### Syntax:

```
itp                  tunnel-id
                        size
                        rate
```

*tunnel-id*

Required. A 2-byte integer value assigned to a specific tunnel.

*size* Optional. The size of the ping packet's data payload. This value must be greater than the minimum size created by itp, and less than the tunnel's MTU value.

*rate* Optional. The frequency (in seconds) at which the ping data packet is transmitted.

**Default Value:** 1

### List

Use the **list** command to display the current IP Security configuration. Global tunnels include all tunnels in the router, both active and defined. All tunnels include all tunnels configured on this interface, both active and defined. Active tunnels are those that are currently active; defined tunnels are defined but not active.

#### Syntax:

```
list ...            all
```

## IP Security Monitoring Commands (Talk 5)

global  
tunnel

active tunnel-id tunnel-name all  
defined tunnel-id tunnel-name all

### Example: Listing all defined tunnels

```
IPV4-IPsec>LIST TUNNEL DEFINED
Enter the Tunnel ID, Tunnel Name, or 'ALL' [ALL]?
```

Defined Tunnels for IPv4:

ID	Type	Local IP Addr	Remote IP Addr	Mode	State
3	ISAKMP	211.0.1.17	211.0.5.2	TUNN	Enabled
4	ISAKMP	211.0.1.17	211.0.5.3	TUNN	Enabled
5	ISAKMP	211.0.1.17	211.0.5.4	TUNN	Enabled

Defined Manual Tunnels for IPv6:

```
IPV4-IPsec>
```

### Example: Listing one defined tunnel

```
IPV4-IPsec>LIST TUNNEL DEFINED
Enter the Tunnel ID, Tunnel Name, or 'ALL' [ALL]? 1
```

Tunnel ID	Type	Mode	Policy	Life	Replay	State	Prev
1	ISAKMP	TUNN	ESP	0	No	Enabled	

Tunnel Name: -----

Local (Outbound) Information:

IP Address: 211.0.1.17

Authentication: SPI: ----- Algorithm: -----

Encryption: SPI: 2305164930 Encryption Algorithm: DES-CBC

Extra Pad: 0

ESP Authentication Algorithm: HMAC-MD5

Remote (Inbound) Information:

IP Address: 211.0.5.3

Authentication: SPI: ----- Algorithm: -----

Encryption: SPI: 2661613010 Encryption Algorithm: DES-CBC

Verify Pad?: No

ESP Authentication Algorithm: HMAC-MD5

```
IPV4-IPsec>
```

### Example: Listing all active tunnels

```
IPV4-IPsec>LIST TUNNEL ACTIVE
Enter the Tunnel ID, Tunnel Name, or 'ALL' [ALL]?
```

Tunnel Cache for IPv4:

ID	Local IP Addr	Remote IP Addr	Mode	Policy	Tunnel Expiration
1	211.0.1.17	211.0.5.214	TUNN	ESP	none
2	211.0.1.17	211.0.5.215	TUNN	ESP	none
3	211.0.1.17	211.0.5.41	TUNN	ESP	none

Tunnel Cache for IPv6:

-----  
 IPV4-IPsec>

### Example: Listing one active tunnel

```

IPV4-IPsec>LIST TUNNEL ACTIVE 1
                        Tunnel ID: 1
                        Tunnel Name: -----
                                Type: ISAKMP
                                Mode: TUNN
                                Policy: ESP
                        Replay Prevention: No
                                Tunnel LifeTime: 0 secs
                        Tunnel Expiration: None
                                PMTU: n/a
                                Tunnel State: Enabled
                                DF bit handling: COPY
                                SA State: Working
                                SA LifeTime: 360 secs
                                SA LifeSize: 50000 KBytes
                                SA Threshold: 85 percent

Local (Outbound) Information:
  IP Address: 211.0.1.17
  Authentication: SPI: ----- Algorithm: -----
  Encryption: SPI: 2861614221 Encryption Algorithm: DES-CBC
                                Extra Pad: 0
                                ESP Authentication Algorithm: HMAC-MD5

Remote (Inbound) Information:
  IP Address: 211.0.5.41
  Authentication: SPI: ----- Algorithm: -----
  Encryption: SPI: 2266666369 Encryption Algorithm: DES-CBC
                                Verify Pad?: No
                                ESP Authentication Algorithm: HMAC-MD5

IPV4-IPsec>
```

**2** This is an IPv6 address. If the IP version is IPv4, a message is displayed that defines the handling of the DF bit: COPY, SET, or CLEAR.

### Reset

Use the **reset** command to dynamically reset IP security on the router or on a single tunnel. After you reset IPsec or the tunnels, be sure to use the **reset IP** command to reset the IP configuration. This is necessary to reload the access control information, such as packet filters and their access control rules. If you do not reset IP, the packet filters and access control rules may not support your new IPsec configuration.

Rebooting the router is an alternative to using the **reset** commands. However, rebooting the router takes it off the network for a time, whereas the **reset** commands interrupt only IP functions.

### Syntax:

```

reset                ipsec
                    tunnel tunnel-id tunnel-name all
```

**ipsec** Resets IP security on the 2212. IP security is temporarily disabled and then restarted. While IP security is disabled, any packets that are normally handled by IPsec tunnels are dropped until the reset is complete. Resetting IP security does not affect other functions on the 2212. This command activates the IP security configuration that was created using Talk 6. The Talk 6 IP security configuration overwrites the Talk 5 configuration.



## IP Security Monitoring Commands (Talk 5)

total pkts	AH packets	ESP packets	total bytes	AH bytes	ESP bytes
-----	-----	-----	-----	-----	-----
0	0	0	0	0	0
Receive Packet Errors:					
total errs	AH errors	AH bad seq	ESP errors	ESP bad seq	
-----	-----	-----	-----	-----	
0	0	0	0	0	
Send Packet Errors:					
total errs	AH errors	ESP errors			
-----	-----	-----			
0	0	0			

---

## Monitoring Manual IP Security (IPv6)

This section explains how to monitor manual IPsec with IPv6. It describes how to access the IP security environment and the available commands.

### Accessing the IP Security Monitoring Environment

To access the IP Security monitoring environment type **t 5** at the OPCON prompt (\*):

```
* t 5
```

Then, enter the following sequence of commands at the **+** prompt:

```
+ feature ipsec  
IPSP>ipv6  
IPV6-IPsec>
```

### IP Security Monitoring Commands (IPv6)

The IP Security monitoring commands for IPv6 are the same as those used for IPv4 unless indicated otherwise. See “IP Security Monitoring Commands (IPv4)” on page 381 for a description of the commands. Enter the commands at the IPV6-IPsec> prompt.

---

## IP Security Dynamic Reconfiguration Support

This section describes dynamic reconfiguration (DR) as it affects Talk 6 and Talk 5 commands.

### CONFIG (Talk 6) Delete Interface

IP Security (IPSec) does not support the CONFIG (Talk 6) **delete interface** command.

### GWCON (Talk 5) Activate Interface

The GWCON (Talk 5) **activate interface** command is not applicable for IPSec. IPSec is independent from a particular interface.

### GWCON (Talk 5) Reset Interface

The GWCON (Talk 5) **reset interface** command is not applicable for IPSec. IPSec is independent from a particular interface.

### GWCON (Talk 5) Component Reset Commands

IPSec supports the following IPSec-specific GWCON (Talk 5) **reset** commands:

## IP Security Monitoring Commands (Talk 5)

### GWCON, Feature IPsec, Ipv4, Reset IPsec Command

**Description:**

IPsec will be reinitialized.

**Network Effect:**

When IPsec is reset, all the tunnels will be gone. Manual tunnels will be rebuilt from SRAM. Negotiated tunnels will disappear. This will cause traffics that use these tunnels stop momentary.

**Limitations:**

None.

The following table summarizes the IP Security Feature configuration changes that are activated when the **GWCON, feature IPsec, ipv4, reset IPsec** command is invoked:

Commands whose changes are activated by the GWCON, feature ipsec, ipv4, reset ipsec command
CONFIG, feature ipsec, ipv4, enable tunnel
CONFIG, feature ipsec, ipv4, disable tunnel
CONFIG, feature ipsec, ipv4, disable ipsec
CONFIG, feature ipsec, ipv4, add tunnel
CONFIG, feature ipsec, ipv4, delete tunnel
CONFIG, feature ipsec, ipv4, change tunnel

### GWCON, Feature IPsec, Ipv4, Reset Tunnel Command

**Description:**

Tunnel or all tunnels will be reinitialized.

**Network Effect:**

A tunnel or all tunnels can be reset. Manual tunnels will be rebuilt from SRAM. Negotiated tunnels will disappear. This will cause traffics that use these tunnels stop momentary.

**Limitations:**

None.

The following table summarizes the IP Security Feature configuration changes that are activated when the **GWCON, feature IPsec, ipv4, reset tunnel** command is invoked:

Commands whose changes are activated by the GWCON, feature ipsec, ipv4, reset tunnel command
CONFIG, feature ipsec, ipv4, add tunnel
CONFIG, feature ipsec, ipv4, delete tunnel
CONFIG, feature ipsec, ipv4, change tunnel
CONFIG, feature ipsec, ipv4, disable tunnel

## GWCON (Talk 5) Temporary Change Commands

IPsec supports the following GWCON commands that temporarily change the operational state of the device. These changes are lost whenever the device is reloaded, restarted, or you execute any dynamically reconfigurable command.

Commands
----------

## IP Security Monitoring Commands (Talk 5)

GWCON, feature ipsec, ipv4, change tunnel <b>Note:</b> A tunnel's parameters can be changed in memory.
GWCON, feature ipsec, ipv4, disable tunnel <b>Note:</b> A tunnel or all tunnels can be disabled. Traffic for these tunnels will be stopped.
GWCON, feature ipsec, ipv4, disable IPSec pass <b>Note:</b> IPSec is disabled and traffic is forwarded without security.
GWCON, feature ipsec, ipv4, disable IPSec stop <b>Note:</b> IPSec is disabled and traffic is discarded.
GWCON, feature ipsec, ipv4, delete tunnel <b>Note:</b> Deletes one or all tunnels. Traffic for these tunnels will be dropped.
GWCON, feature ipsec, ipv4, enable tunnel <b>Note:</b> Enables one or all tunnels. Traffic for these tunnels will be allowed.
GWCON, feature ipsec, ipv4, enable IPSec <b>Note:</b> Enables IPSec. IPSec can process traffic.
GWCON, feature ipsec, ipv4, set path-MTU-age-timer <b>Note:</b> Change path MTU aging timer.

### Non-Dynamically Reconfigurable Commands

The following table describes the IP Security Feature configuration commands that cannot be dynamically changed. To activate these commands, you need to reload or restart the device.

Commands
CONFIG, enable ipsec <b>Note:</b> When IPSec is enabled for the first time after the device has been initialized, the device needs to be reloaded or restarted.

## IP Security Monitoring Commands (Talk 5)



## Chapter 22. Using the Differentiated Services Feature

This chapter describes how to use the Differentiated Services (DiffServ) feature so that a router can provide preferred service to appropriate IP data packets. Based on information in the IP header, the router classifies packets by matching them with predefined configurations in the policy database (created with the policy feature). See “Chapter 18. Using the Policy Feature” on page 271 for details. As a result, some packets may receive preferred service. This chapter consists of the following sections:

- “Overview of Differentiated Services”
- “Differentiated Services Terminology” on page 396
- “Configuring Differentiated Services” on page 397

### Overview of Differentiated Services

Most forwarding devices installed in an IP network today deliver standard best-effort service to data packets on a first-come, first-served basis. This delivery method is adequate for most traffic, but new applications are emerging that require faster and earlier transmission of certain packets.

The Differentiated Services (DiffServ) feature provides different levels of service to IP packets when a router processes them for transmission. DiffServ provides some packets with preferred service by reserving system resources (buffers) and link resources (bandwidth) for them. A DiffServ classifier function determines the type of service given to IP packets by examining various fields in the IP header, for example, ranges of IP source and destination addresses and port numbers, protocol type, and incoming DS (TOS) byte. To accomplish this in a scalable way, individual flows are aggregated into streams. Streams are the entities through which DiffServ manages access to buffers and bandwidth. Figure 39 shows how DiffServ processes the packets of a stream.

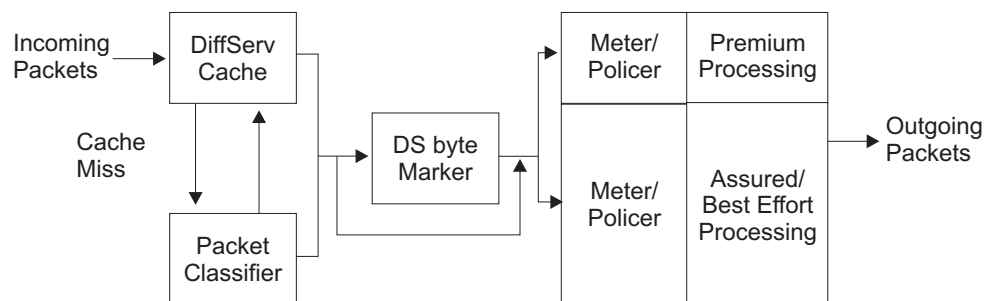

Figure 39. DiffServ Data Packet Path

In addition to the traditional best-effort service, DiffServ provides the following types of service:

#### Expedited Forwarding (EF)

Expedited forwarding service represents the DiffServ implementation of premium service and both terms are used interchangeably in the following text. This service guarantees a specific transmission rate and lower delay than either assured forwarding or best-effort service. If excess traffic develops, DiffServ drops the excess traffic. The premium queue provides EF service and is shown in Figure 40 on page 393 as the EF queue.

## Using Differentiated Services

### Assured Forwarding (AF)

Assured forwarding service represents the DiffServ implementation of assured service, and both terms (assured forwarding and assured service) are used interchangeably in the following text. AF service guarantees a specific transmission rate but no delay guarantee. If idle resources exist, DiffServ can send excess traffic at a higher rate.

AF traffic is optionally metered and policed by means of the configuration in the policy. The supported policing types are single-rate and two-rate Three Color Marker (TCM). TCM enables packets to be classified or re-marked based on characteristics of the incoming traffic. Three classifications are provided: Green, Yellow, and Red. The policy provides for the specifying of thresholds for the color classification. The AF/BE queue provides AF service and is shown in Figure 40 on page 393.

### Best Effort (BE)

This is the standard best-effort service, which does not provide service or delay guarantees. You must strike a balance between reserving resources for EF and AF services, leaving enough resources free so that best-effort traffic receives adequate service. The AF/BE queue provides BE service and is shown in Figure 40 on page 393.

Local routers create and send control packets, so you must also leave enough resources free so that they receive adequate service.

DiffServ metering, marking, and policing in an edge router enables the core router in DiffServ-enabled networks to classify packets based on DS (TOS) codepoint and control congestion by dropping non-conforming traffic or decreasing its service level. For example, the core router may discard all red packets, forward yellow packets as best effort, and forward green packet with a low drop probability. This helps to achieve increased throughput and lower delay for preferred traffic in DiffServ-enabled networks.

DiffServ is currently implemented on PPP, Multilink PPP, and Frame Relay links, and can be used by the RSVP subsystem. Figure 39 on page 391 shows how packets of a stream are processed. When a router receives the first packet of a flow (assuming that it is designated for premium service), no indication of its service category exists in the DiffServ cache, so the packet is processed by the slow path. DiffServ invokes a search of the policy database to obtain the packet-handling criteria (policy). The policy-defined action is saved in the DiffServ cache. When the router receives a subsequent packet of this flow, it finds that an entry in the DiffServ cache for the flow already exists, so its policy-defined action is applied and the packet takes the fast path. Thus, subsequent packets from this flow receive premium service.

Figure 40 on page 393 shows the relationship between the policer, buffer management, the queues, and the scheduler—some of the basic components that provide different quality of service levels.

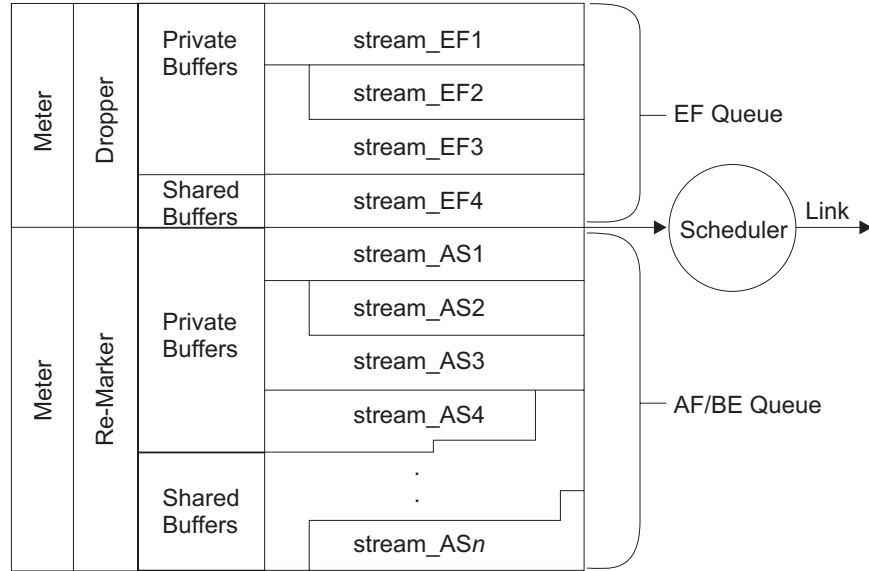

Figure 40. Relationship of Policers, Buffers, Queues, and Scheduler

The expedited forwarding (EF) and assured forwarding (AF) services have different characteristics, which are supported by three functions in the router: (1) The meter and policer, (2) buffer and queue management, and (3) the scheduler. These functions provide more sophisticated traffic control than is available in a traditional BE router device.

Once you have used the policy feature to configure appropriate policies, the first step in implementing DiffServ is to use the DiffServ **enable ds** command to enable the DiffServ feature, and the **set interface** command to enable the egress interface.

It is possible to configure DiffServ options such that the network resources are overcommitted or overbooked, that is, the traffic conditioner controls are configured as though there were more bandwidth or buffering than is actually available. DiffServ does not support overbooking.

If a DiffServ stream becomes idle (no packets have been sent on the stream for some time), the system reclaims the resources so other streams can use them. If the stream reactivates, the resources are returned to it. If the resources are no longer available because of overbooking, then DiffServ periodically attempts to reallocate the resources.

## Understanding the DiffServ Codepoint

DiffServ provides a replacement header for the IPv4 TOS octet as defined in RFC791, which contains a byte called the Diffserv (DS) field (shown in Figure 41). The six high order bits of the DS field are used as a DiffServ codepoint (DSCP) to determine the per-hop-behavior (PHB). The remaining two bits are reserved for future use. The following example shows the format of the DS field:

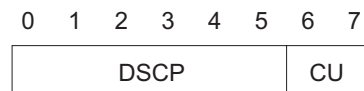

Figure 41. DiffServ Codepoint Format for IPv4 TOS Octet Header

## Using Differentiated Services

where:

DSCP = differentiated services codepoint

CU = currently unused

The recommended codepoint for the EF PHB is 101110xx.

Figure 42 shows the format of the DS field for the AF PHB:

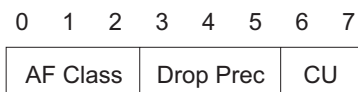

Figure 42. DiffServ Codepoint Format for AF PHB Header

where:

Three bits for AF class type

001 - AF11 class

010 - AF21 class

011 - AF31 class

100 - AF41 class

Three bits for drop precedence

010 - Low Drop Precedence, means Green color in TCM

100 - Medium Drop Precedence, means Yellow color in TCM

110 - High Drop Precedence, means Red color in TCM

CU = currently unused

The following list shows the recommended AF codepoint values with AF classes and drop precedence values:

Class 1	Class 2	Class 3	Class 4
AF11 = 001010xx	AF21 = 010010xx	AF31 = 011010xx	AF41 = 100010xx
AF12 = 001100xx	AF22 = 010100xx	AF32 = 011100xx	AF42 = 100100xx
AF13 = 001110xx	AF23 = 010110xx	AF33 = 011110xx	AF43 = 100110xx

## Understanding the Meters and Policer

Metering and policing is provided for EF and AF traffic as specified in policy. The EF algorithm meters the traffic and drops packets that are over the specified threshold. The AF algorithm meters the traffic and possibly re-marks packets, but does not drop.

### Expedited Forwarding (EF)

EF traffic has a default, token bucket-based policer, which drops packets if they exceed the rate specified during policy bandwidth parameter setup. You may specify the Token Rate (TR) and Token Bucket Size (TBS) parameters to change the policer default operation. The meter determines whether the bucket contains a sufficient number of tokens to send a packet. If tokens are available, the packet is sent. If not, the policer drops the packet. The bucket replenishes tokens at the rate specified in the Token Rate parameter. The token rate is measured in bytes per second, that is, it includes the IP header, but not link-specific headers. The token rate is measured before the IP header compression and Layer 2 data encryption and compression. Token Bucket Size is used to handle temporary bursts over the rate limit without penalty.

## Assured Forwarding (AF)

AF traffic has three policing options: (1) single-rate Three Color Marker (srTCM), (2) two-rate Three Color Marker (trTCM), and (3) none (no policing). These policing options are available for AF1, AF2, AF3 and AF4 classes and are specified during policy setup.

The srTCM meters a traffic stream based on a token bucket algorithm with two buckets and a single replenishment rate. It marks its packets as either green, yellow, or red according to three traffic parameters: (1) Committed Information Rate (CIR), (2) Committed Burst Size (CBS), and (3) Excess Burst Size (EBS). A packet is marked green if it does not exceed the CBS, yellow if it does exceed the CBS but not the EBS, and red otherwise. The CIR is measured in bytes of IP packets per second, that is, it includes the IP header, but not link-specific headers. The CIR is measured before the IP header compression and Layer 2 data encryption and compression. The CBS and the EBS are measured in bytes.

The meter operates in either color-blind or color-aware mode. In color-blind mode, an incoming packet is assumed to be marked green, regardless of the setting of the drop precedence bits in its DS codepoint. CBS represents the size of the green bucket, and EBS represents the size of the yellow bucket. First, the green bucket is checked for available tokens. If there are enough green tokens, then the packet is marked as green and sent. If there are not enough green tokens, then the yellow bucket is checked. If there are enough yellow tokens, then the packet is marked as yellow and sent. If there are not enough yellow tokens, then the packet is marked as red. In color-aware mode, the color of the incoming packet is checked and the corresponding token bucket is checked first. If tokens are available it is sent as received. If not, its drop precedence value is reduced appropriately. Color-aware mode is useful if ingress packets are already classified and pre-color marked.

The trTCM is also a token bucket algorithm, similar to srTCM, except that it provides separate replenishment rates for the green and yellow buckets. The configuration parameters are: (1) Committed Information Rate (CIR), (2) Committed Burst Size (CBS), (3) Peak Information Rate (PIR), and (4) Peak Burst Size (PBS). CBS represents the size of the green bucket, and PBS represents the size of the yellow bucket. The algorithm is the same as for srTCM, except that the CIR value determines the green bucket replenishment rate and the PIR value determines the yellow bucket replenishment rate. The trTCM is useful if a peak rate needs to be enforced separately from a committed information rate. The packets that exceed the PIR will be marked red (highest drop probability).

## Understanding Buffer and Queue Management

If traffic is for EF, or is AF or BE traffic that the policer has allowed, the rate-based *buffer management* function processes it. This function allocates buffers from either a private pool or from a common shared pool for the DiffServ-enabled output interface. Buffers for EF traffic are allocated only from the private pool.

Use the Talk 6 **set receive-buffers** configuration command (see *Access Integration Services Software User's Guide* for a description and the syntax) to specify the total amount of physical buffer space available to an interface. Use the DiffServ Talk 6 **set interface** command to set the egress buffer size for the premium and assured queues. This is the buffer space that DiffServ manages.

DiffServ manages two separate pools—one for the premium (EF) queue and one for the assured forwarding (AF) queue. Ensure that the buffer space you specify reflects the actual amount of buffer space available in the system.

## Using Differentiated Services

Buffer management determines whether buffers from its interface's private pool are available for the packet. If there are, it accepts and enqueues the packet. If they are not, it attempts to allocate buffer space from the shared pool and if it can, it enqueues the packet. If no shared buffer space is available, buffer management drops the packet.

## Understanding the Scheduler

The *scheduler* function examines the queues on a regular basis, dequeues enqueued packets, and sends them to the interface adapter for transmission. It is a self-clocked fair-queuing scheduler, which is a variation of weighted fair queuing. You may configure the scheduler weights and specify the frequency at which the scheduler examines the queues.

---

## Differentiated Services Terminology

The following terms are used when discussing DiffServ:

### **Committed Information Rate (CIR)**

This parameter specifies the maximum rate at which a user's AF traffic stream is allowed to operate before becoming considered as oversending. It is measured in bytes of IP packets per second (including the IP header but not the link-specific headers). This is used by both the single-rate and two-rate TCM functions for AF streams.

### **Committed Burst Size (CBS)**

This parameter specifies (in bytes of IP packets) the maximum number of bytes that can be sent out in a burst, at a rate exceeding the CIR. The CBS limits the size of the committed token bucket in both the single-rate TCM and two-rate TCM functions.

### **DiffServ Cache**

This cache contains the traffic and service profile of the most recently active IP flows being serviced by the router.

### **Excess Burst Size (EBS)**

This parameter specifies (in bytes of IP packets) the maximum number of bytes that can be sent out in a burst in excess of the CBS, at a rate exceeding the CIR. This parameter is used by the single-rate TCM functions, and limits the size of the excess token bucket.

**Flow** A sequence of packets with the same source address and port, IP protocol, and destination address and port.

### **Token Rate**

This parameter specifies the maximum rate at which a user's EF traffic stream is allowed to operate before being considered as oversending. It is measured in bytes of IP packets per second (including the IP header but not the link-specific headers).

### **Token Bucket Size**

This parameter measures the maximum number of bytes of IP packets of an EF traffic stream that can be sent out in a burst at a rate exceeding the token rate.

### **Peak Bucket Size (PBS)**

This parameter is used only by the two-rate TCM functions. It specifies (in bytes of IP packets) the maximum number of bytes that can be sent out in a burst at a rate exceeding the PIR. This parameter limits the maximum size of the peak token bucket.

**Peak Information Rate (PIR)**

This parameter is used by the two-rate TCM functions only. It represents the peak rate (in bytes of IP packets per second, including the IP header but not the link-specific headers) at which the user can send AF stream packets, beyond which the drop priority of the packet is set to the highest value.

**Stream**

An aggregation of flows.

**Virtual Interface (VIF)**

For Frame Relay links, each DLCI connection is considered to be a virtual interface.

---

## Configuring Differentiated Services

The following procedures provide a high-level description of how to configure DiffServ to provide preferred service for selected packets. First, access the DiffServ feature:

1. At the \* prompt, enter **talk 6**.
2. At the Config> prompt, enter **feature ds**. This displays the DS config> prompt and opens the configuration dialog.

```
* talk 6
Config>feature ds
DS config>
```

3. Enable the DiffServ feature on a router:

```
DS config>enable ds
DiffServ enabled
```

4. Enable and set the interface parameters:

```
DS config>set interface
Enter Diffserv Interface number [0]? 2
Set Premium Queue Bandwidth (%) (1 - 99) [20]?
  Assured Queue Bandwidth (%) = 80
Configure Advanced setting (y/n)? [No]: no
Accept input (y/n)? [Yes]:
```

**Note:** If you specify no to the Configure Advanced setting prompt, then default parameters for Premium Queue and Assured/BE queue will be used.

```
Configure Advanced setting (y/n)? [No]: yes
Set Premium Queue Weight (%) (20 - 99) [90]?
  Assured Queue Weight (%) = 10
EGRESS BufSize for Premium Queue (in bytes) (550 - 27500) [5500]?
Max EGRESS QoS Allocation for Premium Queue (%) (1 - 99) [95]?
EGRESS BufSize for Assured/BE Queue (in bytes) (5500 - 140800) [27500]?
Max EGRESS QoS Allocation for Assured/BE Queue (%) (1 - 99) [80]?
```

In this example, 20 percent of line bandwidth, and 90 percent of scheduler weight are given to the EF queue. The egress buffer size for the EF queue is 5500 bytes (which is 10 packets with an average packet size of 550 bytes), out of which 95 percent is allocatable to QoS streams. The egress buffer size for the AF/BE queue is 27 500 bytes (which is 50 packets with an average packet size of 550 bytes), out of which 80 percent is allocatable to QoS streams.

## Using Differentiated Services

5. When you have finished enabling DiffServ on routers and setting interface parameters, enter **Ctrl-P** to return to the \* prompt.

After enabling DiffServ and setting interface parameters, you must restart or reload the device to activate DiffServ. For more details on specifying DiffServ commands, see “Chapter 23. Configuring and Monitoring the Differentiated Services Feature” on page 399.



---

## Chapter 23. Configuring and Monitoring the Differentiated Services Feature

This chapter describes the commands provided by the Differentiated Services (DiffServ) feature for configuring routers and interfaces to provide preferred service for selected data packets. It includes the following sections:

- “Accessing the Differentiated Services Configuration Prompt”
- “Differentiated Services Configuration Commands”
- “Accessing the Differentiated Services Monitoring Environment” on page 403
- “Differentiated Services Monitoring Commands” on page 404
- “Differentiated Services Dynamic Reconfiguration Support” on page 410

---

### Accessing the Differentiated Services Configuration Prompt

To enter DiffServ configuration commands:

1. Enter **talk 6** at the OPCON (\*) prompt.
2. Enter **feature ds** at the Config> prompt.

The DS Config> prompt displays. You may now enter DiffServ configuration commands.

---

### Differentiated Services Configuration Commands

These commands enable you to configure the DiffServ options, which designate preferred service for selected data packets. Table 47 summarizes the DiffServ configuration commands, and the rest of this section describes them in detail. Enter the commands at the DS Config> prompt. Either enter the command and options on one line, or enter only the command and then respond to the prompts. To see a list of valid command options, enter the command with a question mark instead of options.

Table 47. DiffServ Configuration Commands

Command	Function
? (Help)	Displays all the commands available for this command level or lists the options for specific commands (if available). See “Getting Help” on page xxxii.
Delete	Deletes a DiffServ configuration record from a router’s SRAM.
Disable	Disables DiffServ either in a router or on a specific egress interface.
Enable	Enables DiffServ either in a router or on a specific egress interface.
List	Displays information about a router’s DiffServ system and interface-related settings.
Set	Specifies a router’s DiffServ-related settings.
Exit	Returns you to the previous command level. See “Exiting a Lower Level Environment” on page xxxii.

#### Delete

Use the **delete** command to delete a DiffServ system configuration record or interface record from a router’s SRAM.

**Syntax:** delete ds  
interface

**ds** Deletes the router’s DiffServ system configuration record.

**Example:**

## DiffServ Configuration Commands (Talk 6)

```
DS Config> delete ds
Diffserv system config record deleted
```

**interface** Prompts you for the interface number to delete.

**Example:**

```
DS Config> delete interface
Enter Diffserv Interface number to delete [0]? 3
Diffserv interface config record deleted
```

## Disable

Use the **disable** command to disable the DiffServ function either in a router or on a specific egress interface.

**Syntax:** disable ds  
interface

**ds** Disables the router's DiffServ function.

**Example:**

```
DS Config> disable ds
DiffServe feature disabled
```

**interface** Prompts you for the number of the interface to disable.

**Example:**

```
DS Config> disable interface
Enter Interface number [0]? 2
DiffServe interface disabled
```

## Enable

Use the **enable** command to enable the DiffServ function either in a router or on a specific egress interface.

**Syntax:** enable ds  
interface

**ds** Enables the router's DiffServ function.

**Example:**

```
DS Config> enable ds
DiffServe feature enabled
```

**interface** Prompts you for the number of the interface to enable.

**Example:**

```
DS Config> enable interface
Enter Interface number [0]? 2
DiffServe interface enabled
```

**Note:** DiffServ can be enabled only on PPP and Frame Relay links.

## List

Use the **list** command to display information about a router's DiffServ system and interface-related settings.

## DiffServ Configuration Commands (Talk 6)

**Syntax:** list                            all  
  ds  
  interface

**all**                                    Displays information about a router's DiffServ and interface configurations.

**ds**                                     Displays a router's DiffServ configuration.

**Example:**

```
DS Config> list ds
```

```
System Parameters:
```

```
DiffServ:           ENABLED
Packet_size:        550
Min BE Alloc (%):   10
Min CTL Alloc (%):  5
Number_of_Q:        2
```

**interface**                        Displays the interfaces in a router, their DiffServ enable/disable status, and the parameters for each interface and queue.

**Example:**

```
DS Config> list interface
```

```
----- Premium ----- Assured -----
Net If      Status NumQ Bwdth Wght OutBuf MaxQos Bwdth Wght OutBuf MaxQos
Num                                     (%)(%) (bytes) (%) (%) (%) (bytes) (%)
-----
2 PPP Enabled  2   20   90  5500   95   80   10  27500   80
3 PPP Enabled  2   20   90  5500   95   80   10  55000   80
```

## Set

Use the **set** command to set a router's DiffServ system and interface-related parameters.

**Syntax:** set                            be-alloc-min  
  ctl-alloc-min  
  interface  
  pkt-size

**be-alloc-min**                       Specifies the minimum percentage of total output buffer space to allocate to best-effort service.

**Default value: 10**

**Example:**

```
DS Config> set be-alloc-min
```

```
Enter Minimum percent output BW allocated to BE service (10 - 50) [10]?
```

**ctl-alloc-min**                       Specifies the minimum percentage of total output buffer space to allocate to network control service.

**Default value: 5**

**Example:**

```
DS Config> set ctl-alloc-min
```

```
Enter Minimum percent output BW allocated to CTL service (5 - 20) [5]?
```

## DiffServ Configuration Commands (Talk 6)

**interface** Specifies the interface to enable for DiffServ and prompts you for interface-specific parameters.

### **Queue bandwidth**

Specifies the percentage of the output link to be used for the premium queue. The remaining percentage is used for the assured queue value.

**Default value: 20**

### **Queue weight**

Specifies the percentage of time that the scheduler monitors the premium queue. The remaining percentage is used for the assured queue value. The queue weight is defaulted to 90 percent so that the scheduler reacts quickly to EF traffic.

**Default value: 90**

### **Egress buffer size**

Specifies the amount of data (in bytes) that can be queued on the premium queue and the assured queue.

For the premium queue, this parameter controls the amount of data (in bytes) that can be queued on the premium queue. Too large a value for this parameter could cause a high queuing delay for the premium traffic. For example, if this is set to 25 kilobytes and the output link speed is 1.5 Mbps (T1 speed), then there is a potential queuing delay of 133 msec ( $25\,000\text{ bytes} * 8\text{ bits/byte} / 1\,500\,000\text{ bps}$ ), or 0.133 sec (133 milliseconds). Too small a value for this parameter could make it impossible to buffer small bursts. For example, if this is set to 2 kb, it implies that there will not be sufficient buffering for a 2-packet burst of 1500-byte packets (because they require 3000 bytes of buffer space).

As a compromise between these two extremes, the default setting is 5500 bytes, which is ten times the default packet size of 550.

**Default value: 5500 (premium queue)**

For the assured queue, this parameter controls the amount of data (in bytes) that can be queued on the assured queue. The considerations for this parameter value are the same as for the premium queue, except that the traffic in the assured queue does not have very strict delay requirements. Rather, it is more likely that assured queue traffic will consist of TCP flows, which are bursty in nature. Because of this, enough buffer space must be defined to accommodate bursts from several flows.

The default size is 27 500 bytes, which is fifty times the default packet size of 550.

**Default value: 27500 (assured queue)**

### **Egress QoS allocation**

Specifies the amount of the egress buffer size value (as a percentage) that all the DiffServ streams can reserve. The remaining percentage is used for the minimum size of the shared pool.

## DiffServ Configuration Commands (Talk 6)

Default value: 95 (premium queue)

Default value: 80 (assured queue)

### Notes:

1. For Multilink PPP, enable DiffServ on the bundle virtual interface. Enabling DiffServ on an individual link of the bundle interface is not allowed.
2. For Frame Relay subinterfaces, enable DiffServ on the base Frame Relay net. Enabling DiffServ on subinterfaces is not allowed.

### Example:

```
DS Config> set interface
Enter Diffserv Interface number [0]? 2

DiffServ Interface enabled

Set Premium Queue Bandwidth (%) (1 - 99) [20]?
Assured Queue Bandwidth (%) = 80

Configure Advanced setting (y/n)? [No]: y

Set Premium Queue Weight (%) (20 - 99) [90]?
Assured Queue Weight (%) = 10

EGRESS BufSize for Premium Queue (in bytes) (550 - 27500) [5500]?
Max EGRESS QoS Allocation for Premium Queue (%) (1 - 99) [95]?

EGRESS BufSize for Assured/BE Queue (in bytes) (5500 - 140800) [27500]?
Max EGRESS QoS Allocation for Assured/BE Queue (%) (1 - 99) [80]?

DiffServ Interface: ENABLED
PREMIUM Queue Bandwidth (%) = 20
PREMIUM Queue Weight (%) = 80
PREMIUM Queue EGRESS BufSize in bytes = 5500
PREMIUM Queue Max EGRESS QoS allocation (%) = 95
ASSURED/BE Queue Bandwidth (%) = 80
ASSURED/BE Queue Weight (%) = 20
ASSURED/BE Queue EGRESS BufSize in bytes = 27500
ASSURED/BE Queue Max EGRESS QoS allocation (%) = 80
Accept input (y/n)? [Yes]:
```

### pkt-size

Specifies the average packet size of the traffic flow (in bytes). This enables DiffServ to determine the available buffer space on the ingress and egress interfaces. If this is changed, the router must be restarted and the DiffServ **set interface** command values should be reviewed and changed if necessary.

Default value: 550

### Example:

```
DS Config> set pkt-size
Average packet size (64 - 64000) [550]?
```

---

## Accessing the Differentiated Services Monitoring Environment

The console portion of the DiffServ feature enables you to view and manage DiffServ-related settings. To access the DiffServ monitoring environment enter **talk 5** at the OPCON prompt (\*):

```
* t 5
```

Then, enter the following command at the **+** prompt:

## Monitoring DiffServ (Talk 5)

+ feature ds  
DS Console>

---

### Differentiated Services Monitoring Commands

These commands enable you to view DiffServ-related settings. Table 48 summarizes the DiffServ monitoring commands and the rest of this section describes them. Enter the commands at the DS Console> prompt. Either enter the command and options on one line, or enter only the command and then respond to the prompts. To see a list of valid command options, enter the command with a question mark instead of options.

Table 48. DiffServ Monitoring Commands

Command	Function
? (Help)	Displays all the commands available for this command level or lists the options for specific commands (if available). See “Getting Help” on page xxxii.
Clear	Clears statistics for a stream between a specific ingress and egress interface pair.
DScache	Clears or displays information in a router’s DiffServ cache.
List	Displays information about a router’s DiffServ system and interface-related settings.
Exit	Returns you to the previous command level. See “Exiting a Lower Level Environment” on page xxxii.

### Clear

Use the **clear** command to clear statistics for a stream between a specific ingress and egress interface pair.

**Syntax:** clear stream-stats

**Example:**

```
DS Console> clear stream-stats
Incoming Network number : 0
Outgoing Network number : 2
Net 0->2 stream stats cleared at sysclock 85327 Second.
```

### DScache

Use the **dscache** command to clear or display information in a router’s DiffServ cache.

**Syntax:** dscache actions  
clear  
nexthop  
order  
stats

**actions** Displays the actions to be taken for packets sent from the specified IP source to the specified IP destination, and the DiffServ stream ID, if any.

**Example:**

## DiffServ Monitoring Commands (Talk 5)

```
DS Console> dscache actions
Source Address to list []?
Destination Address to list []?
Source      Destination      Pro ProtocolInf Net TosIn/Out Action StrmID
10.1.100.1  9.1.140.1        1 T:x08 C:x00    0 x00->x15 PASS 85
9.1.140.1   10.1.100.1       1 T:x00 C:x00    1 x00->x15 PASS null
```

**clear** Specifies clearing of the entire DiffServ cache.

**nexthop** Displays the nexthop IP address.

### Example:

```
DS Console> dscache nexthop
Source Address to list []? 5.0.13.248
Destination Address to list []? 5.0.11.249
Source      Destination      Pro ProtocolInf Net Tos NextHop      (PPP/1)
5.0.13.248  5.0.11.249       17 1031> 1031 0 x00 5.0.61.7      (PPP/1)
5.0.13.248  5.0.11.249       17 1032> 1032 0 x00 5.0.61.7      (PPP/1)
5.0.13.248  5.0.11.249       17 1033> 1033 0 x00 5.0.67.1      (PPP/1)
```

**order** Displays the order in which the packets have arrived.

### Example:

```
DS Console> dscache order
Order Source      Destination      Pro ProtocolInf Net Tos
1 5.0.16.246      5.0.13.248      1 T:x03 C:x03 2 x00
2 5.0.13.248      5.0.16.246      17 4000> 5678 0 x00
3 5.0.16.246      5.0.13.244      1 T:x03 C:x03 1 x00
4 5.0.13.248      5.0.15.243      17 123> 123 0 x00
```

**stats** Displays statistics for packets sent from the specified IP source to the specified IP destination.

### Example:

```
DS Console> dscache stats
Source Address to list []? 5.0.13.248
Destination Address to list []? 5.0.11.249
Source      Destination      Pro ProtocolInf Net Tos RxBPkts RxBytes
5.0.13.248  5.0.11.249       17 1031> 1031 0 x00 432 444096
5.0.13.248  5.0.11.249       17 1032> 1032 0 x00 432 444096
5.0.13.248  5.0.11.249       17 1033> 1033 0 x00 437 459516
```

## List

Use the **list** command to display information about a router's DiffServ system and interface-related settings.

**Syntax:** `list` interface  
queue  
stream  
vifs

**interface** Lists the interfaces in a router, their DiffServ enable/disable status, their ingress buffer allocations, and other information.

**Net** Displays the interface number.

### Status

Displays the DiffServ status.

**KB/s** Displays the link speed in kb per second.

## DiffServ Monitoring Commands (Talk 5)

### VirtTime

Displays the virtual time used by the scheduler (indicates n/a for non DiffServ links, indicates 0 if no packets are in progress).

**InMax** Displays the maximum buffer size configured for assured forwarding.

**InCurr** Displays the amount of buffer space currently being used for the input stream. The buffers contain packets in progress.

### InShar

Displays the amount of shared buffer space available for this egress interface.

### InMaxA

Displays the maximum amount of buffer space that can be allocated to all QoS streams in aggregate.

### InCurA

Displays the amount of allocated buffer space available for use by the input stream.

**NumI** Displays the number of input streams.

**NumO** Displays the number of output streams.

### Example:

```
DS Console> list interface
DiffServ interfaces:
Net Status  KB/s  VirtTime  InMax  InCurr  InShar  InMaxA  InCurA  NumI  NumO
-----
0 Disabled  1250    n/a      55000  550    49775  44000  5225   22   n/a
1 Disabled  1250    n/a      27500  0      27500  22000  0      20  n/a
2 Enabled   256     0        27500  0      27500  22000  0      20  3
3 Enabled   256     0        55000  0      55000  44000  0      20  3
4 Disabled  0       n/a      550000 0      550000 550000 0      20  n/a
5 Disabled  0       n/a      550000 0      550000 550000 0      20  n/a
6 Disabled  0       n/a      550000 0      550000 550000 0      20  n/a
7 Disabled  0       n/a      550000 0      550000 550000 0      20  n/a
8 Disabled  2000   n/a      27500  0      27500  22000  0      20  n/a
9 Disabled  0       n/a      550000 0      550000 550000 0      20  n/a
```

### queue

Displays the weights assigned to the DiffServ egress queues, and the buffer allocation status of the egress interfaces.

### Queued packets

Displays the number of packets currently queued (0 indicates that no packets are currently queued).

### Svc Tag

Displays the next virtual time that this queue should receive service.

### Weight

Displays the configured scheduler weight of this queue.

### out\_max\_alloc

Displays the maximum amount of buffer space that can be allocated to a DiffServ stream.

### out\_curr\_alloc

Displays the current amount of buffer space allocated.



## DiffServ Monitoring Commands (Talk 5)

### **out\_max\_buff**

Displays the maximum amount of buffer space for this queue.

### **out\_curr\_buff**

Displays the amount of currently allocated buffer space being used for packets.

### **out\_share\_buff**

Displays the amount of buffer space currently in the shared pool.

### **Example:**

```
DS Console> list queue
OUT Network number : 1
```

```
Premium Queue:
  Queued packets: 0
  Svc Tag:        4294967295
  Weight: 90
  out_max_alloc: 5225 (Bytes)
  out_curr_alloc: 0 (Bytes)
  out_max_buff:  5500 (Bytes)
  out_curr_buff: 0 (Bytes)
  out_share_buff: 5500 (Bytes)
```

```
Assured Queue:
  Queued packets: 0
  Svc Tag:        4294967295
  Weight: 10
  out_max_alloc: 22000 (Bytes)
  out_curr_alloc: 4125 (Bytes)
  out_max_buff:  27500 (Bytes)
  out_curr_buff: 0 (Bytes)
  out_share_buff: 23375 (Bytes)
```

### **stream meter-mark**

Displays information about metering and marking for AF streams.

**Id** Stream identification number

**t** Stream type

**D** DiffServ stream

**B** Best-effort stream

**C** Network control stream

**R** RSVP stream

**l/o q** Output interface queue type

**q1** Premium queue

**q2** Assured/BE queue

**pkt snt**

Total packets sent by this stream.

**buf drp**

Number of packets dropped from this stream because no buffer space was available.

**snt g** Number of green-marked packets sent

**snt y** Number of yellow-marked packets sent.

**snt r** Number of red-marked packets sent

## DiffServ Monitoring Commands (Talk 5)

- g->y** In color-aware mode, number of green-marked packets sent as yellow-marked.
- g->r** In color-aware mode, number of green-marked packets sent as red-marked.
- y->r** In color-aware mode, number of yellow-marked packets sent as red-marked.

### Example:

```
DS Console> list stream meter-mark 0 1
At interface 0, 4 in-streams; clock=25493 sec.
Streams from net 0 to net 1:
-----
Id  t I/o q  pkt snt  buf drp  mrk g  mrk y  mrk r  g->y  g->r  y->r
-----
(af1)
101 D  in    3615    0        0        0        0        0        0        0
    o-q2 3615    0    1223    1222    1770    0        0        0
```

### stream packet-stats

Displays information about the packets in streams.

**Id** Stream identification number

**t** Stream type

**D** DiffServ stream

**B** Best-effort stream

**C** Network control stream

**R** RSVP stream

**I/o q** Output interface queue type

**q1** Premium queue

**q2** Assured/BE queue

**allo/cur(K)**

Total buffer space (in kilobytes) allocated and currently used by this stream.

**tot pkt**

Total packets received for transmission by this stream.

**tot Kby**

Total kilobytes received for transmission by this stream.

**pkt snt**

Total packets sent by this stream.

**Kby snt**

Total kilobytes sent by this stream.

**ovr snt**

Number of packets sent using shared buffers.

**buf drp**

Number of packets dropped from this stream because no buffer space was available.

**pol drop**

Number of packets dropped by the policer on the premium queue.

## DiffServ Monitoring Commands (Talk 5)

### Example:

```
DS Console> list stream packet-stats 0 1
At interface 0, 4 in-streams; clock=25496 sec.
Streams from net 0 to net 1:
-----
```

Id	t	I/o q	allo/cur(K)	tot pkt	tot Kby	pkt snt	Kby snt	ovr snt	buf drp	pol	drp
(af1)											
101	D	in	6.3/ 0.0	3615	3730	3615	3730	0	0		0
		o-q2	6.3/ 0.0			3615	3730	0	0		0
(ef)											
100	D	in	5.2/ 0.0	2393	2469	2393	2469	0	0		0
		o-q1	5.2/ 0.0			2393	2469	0	0		132
(-)											
40	B	in	0.0/ 0.0	0	0	0	0	0	0		0
		o-q2	2.8/ 0.0			0	0	0	0		0
(-)											
	C	in	0.0/ 0.0	0	0	0	0	0	0		0
		o-q2	1.4/ 0.0			0	0	0	0		0

### stream police-para

Displays information about the configured policing parameter for EF and AF streams.

**Id** Stream identification number

**t** Stream type

**D** DiffServ stream

**B** Best-effort stream

**C** Network control stream

**R** RSVP stream

**I/o q** Output interface queue type

**q1** Premium queue

**q2** Assured/BE queue

**TR/CIR in B/s**

Configured token rate or committed information rate in bytes per second.

**TBS/CBS in bytes**

Configured token bucket size or committed burst size in bytes.

**PIR in B/s**

Configured peak information rate in bytes per second.

**EBS/PBS in bytes**

Configured excess bucket size or peak burst size in bytes.

**pol typ**

Type of policing action.

**None** No policing.

**SRCB** Single-rate, color blind TCM.

**SRCA** Single-rate, color-aware TCM.

**TRCB** Two-rate, color blind TCM.

**TRCA** Two-rate, color-aware TCM.

**EF-DRP**

EF policer with default drop action.

## DiffServ Monitoring Commands (Talk 5)

### Example:

```
DS Console> list stream police-para 0 1
At interface 0, 16 in-streams; clock=18429 sec.
Streams from net 0 to net 1:
  Id  t I/o q      TR/CIR      TBS/CBS      PIR      EBS/PBS      pol typ
    --- --- --- --- --- --- --- --- --- ---
(afl)
 101 D  in
      o-q2      25000      4000      0      4000  SRCB
(ef)
 100 D  in
      o-q1      48706      5225                      EF-DRP
```

**vifs** Displays information about Frame Relay virtual interfaces.

### Example:

```
DS Console> list vifs 1

DiffServ virtual interface for dlcI: 17
  Status: Inactive - no packets queued for transmission
  CIR: 64000 (bits/sec)
  Virtual Time: 0
  Service Tag: 0

DiffServ virtual interface for dlcI: 16
  Status: Inactive - no packets queued for transmission
  CIR: 64000 (bits/sec)
  Virtual Time: 0
  Service Tag: 0
```

---

## Differentiated Services Dynamic Reconfiguration Support

This section describes dynamic reconfiguration (DR) as it affects Talk 6 and Talk 5 commands.

### CONFIG (Talk 6) Delete Interface

Differential Services (or DiffServ or DS) supports the CONFIG (Talk 6) **delete interface** command with the following consideration:

It deletes the corresponding DiffServ interface SRAM record. You have to reboot the device to activate this change.

### GWCON (Talk 5) Activate Interface

DiffServ supports the GWCON (Talk 5) **activate interface** command with the following consideration:

DS will follow the normal netup/netdown sequence if a DS-configured interface is activated.

### GWCON (Talk 5) Reset Interface

DiffServ supports the GWCON (Talk 5) **reset interface** command with the following consideration:

- If DiffServ is enabled on this interface, the following things will happen: **reset interface** will clear all the streams created to/from this interface. It will also clear diffserv cache. If BRS is enabled, BRS takes precedence over DiffServ on this interface. For any add/del/change in DiffServ interface SRAM record, you need to reboot the device to activate the change.

## Non-Dynamically Reconfigurable Commands

The following table describes the DiffServ configuration commands that cannot be dynamically changed. To activate these commands, you need to reload or restart

## DiffServ Monitoring Commands (Talk 5)

the device.

Commands
CONFIG, feature DS, enable/disable/del ds
CONFIG, feature DS, enable/disable/del/set interface
CONFIG, feature DS, set be-alloc-min
CONFIG, feature DS, set ctl-alloc-min
CONFIG, feature DS, set pkt-size

## DiffServ Monitoring Commands (Talk 5)

---

## Chapter 24. Using the Random Early Detection Feature

This chapter describes how to use the Random Early Detection (RED) feature so that a network device, based on its configured drop probability, marks random incoming packets for dropping if congestion occurs, thus avoiding an overflow. This benefits well-behaved traffic such as TCP, that responds to the congestion indication by reducing the transmit window size. RED supports PPP, Multilink PPP, and Frame Relay links. This chapter consists of the following section:

- “Using Random Early Detection”

---

### Using Random Early Detection

RED enables you to avoid overflow if congestion occurs. RED calculates the average queue length and if it is within specified limits, based on configurable drop probability, an incoming packet is marked for dropping. Using the *average* queue length instead of the current queue size prevents a bursty traffic queue from affecting the drop rate.

Assume that you have specified the following values for RED parameters:

- 1** Weight factor: 4
- 2** Exponential Maximum Packet Drop Probability: 9
- 3** Minimum Threshold Value: 70
- 4** Maximum threshold Value: 100
- 5** Initial Average Queue Size: 60

**1** This value determines how much influence a current queue has on calculating the average queue length.

The minimum value of this parameter (1) designates less weight and is a conservative setting. With this value, the average queue length at a specific point in time remains closer to the previous average queue length so bursty traffic with a large queue length has little effect on the calculation of new average queue length.

The maximum value of this parameter (8) designates greater weight and is an aggressive setting. With this value, the average queue length is equal to the current queue length so bursty traffic with a large queue length has a great effect on the calculation of new average queue length.

**2** This value is the probability of dropping a packet at peak average queue length.

If the average queue length is consistently equal to the maximum threshold value, one of every  $2^9$  (512) packets is marked for a drop. The probability of a drop increases linearly as the average queue length increases from the minimum threshold to the maximum threshold.

**3** This value designates the minimum queue requirement to calculate a packet's drop probability and mark it accordingly.

It is expressed as a percentage of the maximum device queue value, which is a layer-2 protocol-determined, non configurable value. For example, if you specify a value of 40 percent and the maximum device queue value is 16, then the minimum threshold value is set to 6 ( $0.4 \times 16$ ).

**4** This value designates the maximum queue requirement to calculate a packet's drop probability and mark it accordingly.

It is expressed as a percentage of the maximum device queue value, which is a layer-2 protocol-determined, non configurable value. For example, if you specify

## Using Random Early Detection

a value of 100 percent and the maximum device queue value is 16, then the maximum threshold value is set to 16 ( $1.0 \times 16$ ).

**5** This value designates the initial setting used for calculating packet drop probability.

It is expressed as a percentage of the maximum device queue value, which is a layer-2 protocol-determined, non-configurable value. It prevents bursty traffic from increasing the weight on the average queue length calculation before an average queue value is established by the traffic itself. (When the device is initialized, the queue length is zero and no indication of previous average queue length exists.) You should specify a relatively low value as shown in the preceding example.

After enabling RED and setting interface parameters, you must restart or reload the device to activate RED. For details on specifying RED commands, see “Chapter 25. Configuring and Monitoring the Random Early Detection Feature” on page 415.



---

## Chapter 25. Configuring and Monitoring the Random Early Detection Feature

This chapter describes the commands provided by the Random Early Detection (RED) feature for configuring interfaces to randomly drop packets during congested conditions. It includes the following sections:

- “Accessing the Random Early Detection Configuration Prompt”
- “Random Early Detection Configuration Commands”
- “Accessing the Random Early Detection Monitoring Environment” on page 417
- “Random Early Detection Monitoring Commands” on page 417

---

### Accessing the Random Early Detection Configuration Prompt

To enter RED configuration commands:

1. Enter **talk 6** at the OPCON (\*) prompt.
2. Enter **feature red** at the Config> prompt.

The RED Config> prompt displays. You may now enter RED configuration commands.

---

### Random Early Detection Configuration Commands

These commands enable you to configure the RED options, which determine how packets are dropped during periods of congested traffic. This can prevent overflow and global resynchronization. Table 49 summarizes the RED configuration commands, and the rest of this topic describes them in detail. Enter the commands at the RED Config> prompt. Either enter the command and options on one line, or enter only the command and then respond to the prompts. To see a list of valid command options, enter the command with a question mark instead of options.

Table 49. Random Early Detection Configuration Commands

Command	Function
? (Help)	Displays all the commands available for this command level or lists the options for specific commands (if available). See “Getting Help” on page xxxii.
Delete	Deletes a RED configuration record or interface record from a network device’s SRAM.
Disable	Disables RED either in a network device or on a specific egress interface.
Enable	Enables RED either in a network device or on a specific egress interface.
List	Displays information about a network device’s RED status and interface-related settings.
Set	Specifies RED settings for a specific interface on a network device.
Exit	Returns you to the previous command level. See “Exiting a Lower Level Environment” on page xxxii.

#### Delete

Use the **delete** command to delete a RED configuration record for an interface from a network device’s SRAM.

**Syntax:** delete interface

**interface** Prompts you for the interface number to delete.

**Example:**

## RED Configuration Commands (Talk 6)

```
RED Config> delete interface
Enter RED Interface number to delete [0]? 3
RED interface config record deleted
```

### Disable

Use the **disable** command to disable RED either for a network device or on a specific egress interface.

**Syntax:** disable red  
interface

**red** Disables RED for a network device.

**Example:**

```
RED Config> disable red
RED disabled
```

**interface** Disables RED on a specific egress interface.

**Example:**

```
RED Config> disable interface
Enter RED Interface number [0]? 2
RED interface disabled
```

### Enable

Use the **enable** command to enable RED either for a network device or on a specific egress interface.

**Syntax:** enable red  
interface

**red** Enables RED for a network device.

**Example:**

```
RED Config> enable red
RED enabled
```

**interface** Enables RED on a specific egress interface.

**Example:**

```
RED Config> enable interface
Enter RED Interface number [0]? 2
RED interface enabled
```

**Note:** RED can be enabled only on PPP, Multilink PPP, and Frame Relay links.

### List

Use the **list** command to display information about a network device's RED status and interface-related settings.

**Syntax:** list all

**all** Displays a network device's RED status.

**Example:**

```
RED Config>list all
```

```
RED Status: Enabled
```

```
-----
Status Net If qW maxP minT maxT initAvgQ
```

## RED Configuration Commands (Talk 6)

```
----- %ofdevQ -----  
-----  
Enable 6 PPP 4 1/512 70 100 60
```

Abbreviation:

qW = Queue Weight  
minT = Minimum Threshold, maxT = Maximum Threshold  
maxP = Maximum Drop Probability; 1 drop in 512 pkts  
%ofdevQ = A percentage of the Maximum Device Queue

## Set

Use the **set** command to specify RED settings for a specific interface on a network device.

**Syntax:** `set` interface

**interface** *number*

Specifies the number of the interface for which to set RED options.

**Default value:** none

**Example:**

```
RED config>set interface  
Enter RED Interface number [0]? [6]  
RED Interface enabled  
Exponential Maximum Packet Drop Probability (9 for 1/2e9) (5 - 10) [9]?  
Advanced Setting (y/n)? [Yes]: yes
```

```
Maximum Device Queue = 5  
Weight Factor (1 - 8) [4]?  
Minimum Threshold value (% of the max device queue) (0 - 100) [70]?  
Maximum Threshold value (% of the max device queue) (0 - 100) [100]?  
Initial Average Queue Size (% of the max device queue) (0 - 100) [60]?  
Accept input (y/n)? [Yes]: yes
```

---

## Accessing the Random Early Detection Monitoring Environment

The console portion of the Random Early Detection feature enables you to view and manage RED-related settings. To access the RED monitoring environment enter **talk 5** at the OPCON prompt (\*):

```
* t 5
```

Then, enter the following command at the + prompt:

```
+ feature red  
RED Console>
```

---

## Random Early Detection Monitoring Commands

These commands enable you to view RED-related settings. Table 50 on page 418 summarizes the RED monitoring commands and the rest of this section describes them. Enter the commands at the RED Console> prompt. Either enter the command and options on one line, or enter only the command and then respond to the prompts. To see a list of valid command options, enter the command with a question mark instead of options.

## RED Monitoring Commands (Talk 5)

Table 50. RED Monitoring Commands

Command	Function
? (Help)	Displays all the commands available for this command level or lists the options for specific commands (if available). See “Getting Help” on page xxxii.
Clear	Resets an interface’s RED parameter settings.
List	Displays RED-enabled network device interface settings.
Exit	Returns you to the previous command level. See “Exiting a Lower Level Environment” on page xxxii.

### Clear

Use the **clear** command to reset an interface’s RED parameter settings. The example in the description of the **list** command illustrates the results of the **clear** command.

**Syntax:** `clear` *interface-number*

### List

Use the **list** command to display information about RED-enabled network device interface settings.

**Syntax:** `list` *interface-number*

*interface-number*

Lists the RED settings for the specified interface in a network device.

#### Example:

RED Console>**list 6**

Status	If	maxQ	avgQ	minT (dvQ)	maxT (dvQ)	qW	maxP (pkt)	pktCnt til drp	pdpDepth count	passCnt pkt	drpCnt pkt
Enable	6	5	3	3	5	4	1/512	1:3787	285	4283	1

Abbreviations:

maxQ = Maximum Queue Length, avgQ = Average Queue Size  
 minT = Minimum Threshold, maxT = Maximum Threshold  
 dvQ = Device Queue, qW = Queue Weight  
 maxP = Maximum Drop Probability: 1 drop in 512 pkts  
 pktCnt til drp = Packet Count before a drop occurs  
 pdpDepth = Probability Drop Depth: 1 drop in 2048 depth count

RED Console>**clear 6**

RED Console>**list 6**

Status	If	maxQ	avgQ	minT (dvQ)	maxT (dvQ)	qW	maxP (pkt)	pktCnt til drp	pdpDepth count	passCnt pkt	drpCnt pkt
Enable	6	5	3	3	5	4	1/512	1:3530	0	0	0

Abbreviations:

maxQ = Maximum Queue Length, avgQ = Average Queue Size  
 minT = Minimum Threshold, maxT = Maximum Threshold  
 dvQ = Device Queue, qW = Queue Weight  
 maxP = Maximum Drop Probability: 1 drop in 512 pkts  
 pdkCnt til drp = Packet Count before a drop occurs  
 pdpDepth = Probability drop Depth: 1 drop in 2048 depth count

---

## Chapter 26. Using Layer 2 Tunneling (L2TP, PPTP, L2F)

This chapter discusses Layer 2 Tunneling. It consists of the following sections:

- “Overview of L2TP”
- “L2TP Terms” on page 420
- “Supported Features” on page 420
- “Timing Considerations” on page 422
- “LCP Considerations” on page 422
- “Configuring Layer 2 Tunneling” on page 422

Layer 2 Tunneling (L2T) consists of L2TP, L2F, and PPTP tunneling protocols.

Layer 2 Tunneling Protocol (L2TP) is an IETF standards track protocol for tunneling of PPP across a packet network such as UDP/IP. L2TP is connection oriented.

Layer 2 Forwarding (L2F) and Point to Point Tunneling Protocol (PPTP) are IETF informational protocols for tunneling of PPP across an IP network.

---

### Overview of L2TP

L2TP allows many separate and autonomous protocol domains to share a common access infrastructure including modems, Access Servers, and ISDN routers. L2TP permits the tunneling of the PPP link layer, for example, HDLC and asynchronous HDLC. Using these tunnels, it is possible to disassociate the location of the contacted dial-up server from the location that provides access to the network.

Traditionally, dial-up network service on the Internet is provided for registered IP addresses only. L2TP defines a new class of virtual dial-up application that allows multiple protocols and unregistered IP addresses on the Internet. This class of network application is useful for supporting privately addressed IP, IPX, and AppleTalk dial-ups through PPP across an existing Internet infrastructure.

The support of these multiprotocol virtual dial-up applications is beneficial to end users, enterprises, and Internet service providers because it allows the sharing of significant investments in access and core infrastructure and allows end users to use local calls when accessing the services.

L2TP also enables the secure use of existing investments in non-IP protocol applications within the existing Internet infrastructure.

Figure 43 on page 420 shows an example of an L2TP network using ISDN. The network could use any media type between the L2TP Network Access Concentrator (LAC) and the L2TP Network Server (LNS). The example uses the compulsory tunneling model. This chapter also describes the voluntary tunneling model configuration.

## Using Layer 2 Tunneling

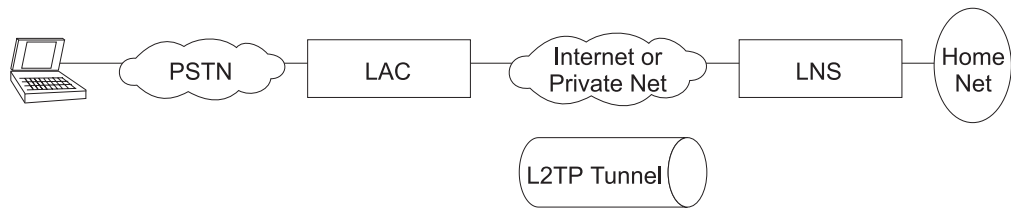

Figure 43. Sample L2TP Network

---

## L2TP Terms

The following terms are used when describing L2TP:

### Attribute Value Pair (AVP)

A uniform method of encoding message types and bodies. This method maximizes the extensibility while permitting interoperability of L2TP.

### L2TP Access Concentrator (LAC)

A device attached to one or more public service telephone network (PSTN) or ISDN lines capable of handling both PPP operation and the L2TP protocol. The LAC implements the media over which L2TP operates. L2TP passes the traffic to one or more L2TP Network Servers (LNS). L2TP can tunnel any protocol carried by the PPP network.

### L2TP Network Server (LNS)

An LNS operates on any platform that can be a PPP end station. The LNS handles the server side of the L2TP protocol. Because L2TP relies only on the single media over which L2TP tunnels arrive, the LNS can have only a single LAN or WAN interface, yet is still able to terminate calls arriving from any PPP interfaces supported by an LAC.

### Network Access Server (NAS)

A device providing temporary, on-demand network access to users. This access is point-to-point using PSTN or ISDN lines.

### Session (Call)

L2TP creates a session when an end-to-end PPP connection is attempted between a dial user and the LNS. The datagrams for the session are sent over the tunnel between the LAC and LNS. The LNS and LAC maintain the state information for each user attached to an LAC.

### Tunnel

A tunnel is defined by an LNS-LAC pair. The tunnel carries PPP datagrams between the LAC and the LNS. A single tunnel can multiplex many sessions. A control connection operating over the same tunnel controls the establishment, release, and maintenance of all sessions and of the tunnel itself.

---

## Supported Features

L2TP runs over UDP/IP and supports the following functions:

- Tunneling of single user dial-in clients.
- Tunneling of small routers, for example a router with a single static route to set up based on an authenticated user's profile.
- Calls can be initiated from the LAC to the LNS (inbound), from the LNS to the LAC (outbound), or by either peer (both). The outbound calls can be *fixed* (always up) or a demand-based L2 tunneling session.

- Multiple calls per tunnel.
- Proxy Authentication for PAP, CHAP and MS-CHAP.
- Proxy LCP.
- LCP restart in the event that Proxy LCP is not used at the LAC.
- Tunnel end-point authentication.
- Hidden AVP for transmitting a proxy PAP password.
- Tunneling using a local rhelm (that is, user@rhelm) lookup table.
- Tunneling using the PPP username lookup in the AAA subsystem.
- Management of L2TP tunnels using SNMP. See “SNMP Management” in the *Protocol Configuration and Monitoring Reference Volume 1*.

**Note:** Rhelm tunneling requires usernames in *name@rhelm* format. Tunneling this way requires the software to look through two tables to resolve the destination to which the dial-in user is tunneled. The advantage of using this method of tunneling is that you need only define the rhelm and any usernames that match the rhelm will be tunneled to the same destination.

User-based tunneling is resolved in a single table. It allows you the granularity of tunneling each user to a unique destination.

- BRS for an LNS (as a PPP end point).
- The ability to use the **delete interface** command to delete L2TP devices.
- The ability to dynamically reconfigure L2TP devices.
- Establishment of a sequencing, queueing, retransmission and flow control channel. L2TP also performs sequencing on the data channel.
- The ability to fix the L2TP UDP port (1701) so you can establish IP Security filters based on the UDP port.
- An L2TP router client. L2TP router client is a “client initiated” (also known as voluntary tunneling) model. This function provides secure, tunneled, multi-protocol Virtual Private Network (VPN) services regardless of service provider topology. This function brings the client and LAC into one physical piece of hardware.
- Connection of an inbound call to the appropriate interface based on a remote hostname match. If the remote hostname does not match any of the interfaces configured for hostname matching, the call is completed on an inbound interface that does not use remote hostname matching.

**Note:** If you have configured multiple net mappings between the same LAC and LNS pair, make sure only one tunnel exists for each mapping.

- Automatic IP, IPX, and bridging configuration of inbound nets that do not use remote hostname matching. You must manually configure outbound nets and inbound nets that use remote hostname matching.

Other supported Layer 2 Tunneling protocols include:

- L2F-Both NAS and gateway functions are supported.
- PPTP-Router client, PAC (PPTP Access Concentrator), and PNS (PPTP Network Server) are supported.

L2F provides interoperable Layer 2 tunneling when connecting to network devices not supporting L2TP.

## Using Layer 2 Tunneling

PPTP provides interoperable Layer 2 tunneling when connecting to network devices not supporting L2TP. Specifically PPTP can be used for VPN services from Microsoft Windows 95 (DUN 1.2 and higher), Windows 98, and Windows NT to IBM routers.

**Note:** Both L2F and PPTP are configured in the Layer 2 Tunneling feature.

---

## Timing Considerations

The nature of tunneling PPP packets over routed networks creates some timing issues that you should consider. L2TP assumes that the connection between the LAC and LNS does not have a delay that is long enough to time out the tunneled peers. If the inter-peer latency repeatedly reaches or exceeds that of the PPP state machine's timeout (usually 3 seconds), then connectivity could be hindered. Note that if the latency between the LAC and LNS is this poor, then connectivity in general is so poor that the connection will be unreasonable even if the PPP state machines were kept alive artificially. If both sides possess the capability, then the PPP timeout may be extended to achieving connectivity over a very poor connection.

Besides latency, a bandwidth mismatch between the LAC/LNS pair and LAC/Client pair may cause problems. For instance, if the actual bandwidth between the LAC and LNS is significantly less than the bandwidth of the PPP client, then the LAC may spend significant time trying to send packets to the LNS. On the other hand, if the connection between the LNS and a host on the LNS home network is exceptionally fast compared with the dial-in client, then the LNS may be overburdened trying to send data to the LAC.

---

## LCP Considerations

When using Proxy LCP, the LAC negotiates LCP and PPP continues processing at the LNS. The LAC forwards LCP options to the LNS so that the LNS is aware of what was negotiated. The LNS must remain flexible to the parameters negotiated by the client and LAC. If there are any parameters that are unacceptable to the LNS, then L2TP attempts to renegotiate LCP by sending an *LCP Configure Request* to the client across the tunnel.

The requirement for the LNS to remain flexible is of particular concern regarding the MRU. On the IBM LNS, the configured MRU is the maximum allowed for Proxy LCP. If the value in the Proxy LCP message from a LAC is greater than the MRU configured on the LNS, then L2TP will attempt to renegotiate LCP with an MRU equal to the configured MRU without changing other LCP options from the LAC.

---

## Configuring Layer 2 Tunneling

To configure L2T:

1. Access the Layer 2 tunneling feature using the **feature** command.

```
Config> feature layer-2-tunneling
Layer-2-Tunneling config>
```

2. Enable L2TP, L2F, and PPTP as required.

```
Layer-2-Tunneling config> enable L2TP
Layer-2-Tunneling config> enable L2F
Layer-2-Tunneling config> enable pptp
```



3. Add any L2T networks needed. If this is to be strictly an LAC, L2F NAS, or PPTP PAC, you do not have to add any L2T nets. You should define one L2T net for each simultaneous tunneled PPP connection.

```

Layer-2-Tunneling Config>ADD L2-NETS
Additional L2 nets: [0]? 10
Add unnumbered IP addresses for each L2 net? [Yes]: yes
Adding device as interface 31
Defaulting Data-link protocol to PPP
Adding device as interface 32
Defaulting Data-link protocol to PPP
Adding device as interface 33
Defaulting Data-link protocol to PPP
Adding device as interface 34
Defaulting Data-link protocol to PPP
Adding device as interface 35
Defaulting Data-link protocol to PPP
Adding device as interface 36
Defaulting Data-link protocol to PPP
Adding device as interface 37
Defaulting Data-link protocol to PPP
Adding device as interface 38
Defaulting Data-link protocol to PPP
Adding device as interface 39
Defaulting Data-link protocol to PPP
Adding device as interface 40
Defaulting Data-link protocol to PPP

```

- a. Configure any L2TP, L2F, or PPTP tunnels.

To configure an L2TP tunnel using an AAA local list:

```

Config>add tunnel-profile
Enter name: []? lns.org
Tunneling Protocol? (PPTP, L2F, L2TP): L2TP
Enter local hostname: []? lac.org
set shared secret? (Yes, No): [No] Y
Shared secret for tunnel authentication:
Enter again to verify:
Tunnel-Server endpoint address: [0.0.0.0]? 11.0.0.1

      PPP user name: lns.org
      Tunnel Server: 11.0.0.1
      Hostname: lac.org

User 'lns.org' has been added
Config>

```

You can use the previous example to configure tunnel authorization on the LAC as well as “rhelm” tunneling in the form of “user@lns.org.”

You can set tunnel authentication and authorization to be done at a particular RADIUS server. See “Using Authentication, Authorization, and Accounting (AAA) Security” in *Using and Configuring Features*.

If you are configuring an LNS and tunnel authentication is disabled on both LAC and LNS, then it is not necessary to configure any tunnel profiles.

To tunnel by PPP username on a LAC using either an AAA local list or RADIUS:

```

Config>add ppp-user
Enter name: []? peter
Password:
Enter again to verify:
Allow inbound access for user? (Yes, No): [Yes]
Will 'peter' be tunneled? (Yes, No): [No] Y
Tunneling Protocol (PPTP, L2F, L2TP): [L2TP] L2TP
Enter local hostname: []? lac.org
Tunnel-Server endpoint address: [0.0.0.0]? 11.0.0.1

      PPP user name: peter
      Tunnel Server: 11.0.0.1
      Hostname: lac.org

Is information correct? (Yes, No, Quit): [Yes]

User 'peter' has been added
Config>

```

## Using Layer 2 Tunneling

- b. Configure remote hostname matching for the inbound tunnels, if required.  
Note that for client dial-in scenarios, this step is typically not necessary. Use this option when a connection should use a specific net.

Assuming that the previous configuration was for net 10:

```
Config> net 10
L2TP 10> set remote-hostname
Remote Tunnel Hostname: [] ibm.com
```

**Note:** To turn off remote hostname matching, use the following commands:

```
Config> net 10
L2TP 10> set any-remote-hostname
```

4. Configure any L2TP outgoing calls. The following example shows a LAC with IP address 1.1.1.1 and an LNS with IP address 1.1.1.2. The LNS is configured to place a dial-on-demand ISDN call to 5552160 from the LAC.

### LNS Configuration:

```
Config> add tunnel-profile
Enter name: []? lac.org
Tunneling Protocol? (PPTP, L2F, L2TP): [L2TP]
Enter local hostname: []? lns.org
set shared secret? (Yes, No): [No] Y
Shared secret for tunnel authentication:
Enter again to verify:
Tunnel-Server endpoint address: [0.0.0.0]? 1.1.1.1

Tunnel name: lac.org
TunnType: L2TP
Endpoint: 1.1.1.1
Hostname: lns.org
```

User 'lac.org' has been added

```
Config>
Config> add dev layer-2-tunneling
Config> net 10
L2TP 10> set connection-direction outbound
L2TP 10> set idle 30
L2TP 10> set remote-hostname lac.org
L2TP 10> enable outbound-call-from-lac
Outbound Call Type (ISDN)? [ISDN]
Outbound calling address: 5552160
Outbound calling subaddress:
L2TP 10>
L2TP 10> encapsulator
PPP 10> set name vickie a
L2TP 10>
L2TP 10> exit
Config> add ppp-user larry b
```

### Notes:

- a. Set authentication name in case the LNS device is authenticated. There are additional prompts that are not shown in this example. For details see, "Configuring PPP Authentication" in the chapter "Using Point-to-Point Protocol Interfaces" in the *Access Integration Services Software User's Guide*.
- b. Add users to be authenticated at the LNS. There are additional prompts that are not shown in this example. See Add in the chapter "The CONFIG Process (CONFIG - Talk 6) and Commands" in *Access Integration Services Software User's Guide* for a description of the command syntax and options.

### LAC Configuration:

```

Config> add tunnel-profile
Enter name: []? lns.org
Tunneling Protocol? (PPTP, L2F, L2TP): [L2TP]
Enter local hostname: []? lac.org
set shared secret? (Yes, No): [No] Y
Shared secret for tunnel authentication:
Enter again to verify:
Tunnel-Server endpoint address: [0.0.0.0]? 1.1.1.2

Tunnel name: lns.org
TunnType: L2TP
Endpoint: 1.1.1.1
Hostname: lac.org

User 'lns.org' has been added
Config>
Config> add dev dial-in a

```

**Note:** Used to place the physical call.

5. Configure any L2T router clients. The following example shows an L2TP box-to-box connection using the L2TP router client function. This connection is set in one direction and is demand-based.

#### Client Configuration:

```

Config> add tunnel-profile
Enter name: []? lns.org
Tunnel Protocol? (PPTP, L2T, L2TP): [L2TP]
Enter local hostname: []? client.org
set shared secret? (Yes, No): [No] Y
Shared secret for tunnel authentication:
Enter again to verify:
Tunnel-Server endpoint address: [0.0.0.0]? 1.1.1.1

Tunnel name: lns.org
TunnType: L2TP
Endpoint: 1.1.1.1
Hostname: client.org

User 'lns.org' has been added
Config>
Config> add dev layer-2-tunneling
Config> net 10
L2TP 10> set connection-direction outbound
L2TP 10> set idle 30
L2TP 10> set remote-hostname lns.org
L2TP 10> encapsulator
PPP 10> set name donald a
PPP 10> exit
L2TP 10> exit
Config>

```

**Note:** Set authentication name in case the client device is authenticated. There are additional prompts that are not shown in this example. For details, see “Configuring PPP Authentication” in *Access Integration Services Software User’s Guide*.

#### LNS Configuration:

```

Config> add tunnel-profile
Enter name: []? client.org
Tunneling Protocol? (PPTP, L2F, L2TP): [L2TP]
Enter local hostname: []? lns.org
set shared secret? (Yes, No): [No] Y

```

## Using Layer 2 Tunneling

```
Shared secret for tunnel authentication:
Enter again to verify:
Tunnel-Server endpoint address: [0.0.0.0]? 1.1.1.2
```

```
Tunnel name: client.org
TunnType: L2TP
Endpoint: 1.1.1.2
Hostname: lns.org
```

```
User 'client.org' has been added
Config>
Config> add dev layer-2-tunneling
Config> net 10
L2TP 10> set connection-direction inbound
L2TP 10> set remote-hostname client.org
Config>
Config> add ppp-user donald b
Config>
```

**Note: b**— Add users to be authenticated at the LNS. There are additional prompts that are not shown in this example. For details see, “**add Config command**” in the *Access Integration Services Software User’s Guide* .

6. Configure the various feature L2T parameters using the **set** and **enable** commands, if desired.

```
Layer-2-Tunneling Config>set ?
Layer-2-Tunneling Config>enable ?
```

7. Configure the PPP parameters for all of the L2 nets which are set for inbound and *\*any\** inbound tunnel hostname using the encapsulator command, if desired.

```
Layer-2-Tunneling Config>encapsulator
PPP-L2TP Config>
```

When you have completed the PPP configuration, enter **exit** to return to the L2T feature configuration environment.

---

## Chapter 27. Configuring and Monitoring Layer 2 Tunneling Protocols

This chapter describes the Layer 2 tunneling (L2T) configuration and operational commands. L2T includes Layer 2 Tunneling Protocol (L2TP), Layer 2 Forwarding Protocol (L2F), and Point-to-Point Tunneling Protocol (PPTP). Sections in this chapter include:

- “Accessing the L2T Interface Configuration Prompt”
- “L2 Tunneling Interface Configuration Commands”
- “Accessing the L2 Tunneling Feature Configuration Prompt” on page 429
- “L2 Tunneling Feature Configuration Commands” on page 429
- “Accessing the L2 Tunneling Monitoring Prompt” on page 434
- “L2 Tunneling Monitoring Commands” on page 435
- “L2 Tunneling Dynamic Reconfiguration Support” on page 441

---

### Accessing the L2T Interface Configuration Prompt

To access the L2T interface configuration prompt:

1. Enter **talk 6** at the OPCON (\*) prompt.
2. Enter **add dev layer-2-tunneling** at the Config> prompt (or use the **add l2-nets** command. See “Add” on page 430).
3. Enter **n interface#** at the Config> prompt.

```
Config> add device layer-2-tunneling
Enter the number of Layer-2-Tunneling interfaces [1]
Adding device as interface 8
Defaulting Data-link protocol to PPP
Config> n 8
Session configuration
L2T config: 8>
```

---

### L2 Tunneling Interface Configuration Commands

Table 51 summarizes the L2T interface configuration commands. Enter these commands at the L2T Config n> prompt (where *n* is the net number).

Table 51. L2 Tunneling Interface Configuration Commands

Command	Function
? (Help)	Displays all the commands available for this command level or lists the options for specific commands (if available). See “Getting Help” on page xxxii.
Disable	Disables outgoing calls.
Enable	Enables outgoing calls.
Encapsulator	Allows you to configure PPP parameters the L2T interface. <b>Note:</b> The encapsulator option is only available if an interface has a remote-hostname configured.
List	Displays information about the L2T interface.
Set	Allows you to set various L2T interface parameters.
Exit	Returns you to the previous command level. See “Exiting a Lower Level Environment” on page xxxii.

#### Disable

Use the **disable** command to disable outbound calls from the L2TP access concentrator (LAC).

#### Syntax:



## L2 Tunneling Interface Configuration Commands (Talk 6)

*\_remote-hostname*

### **any-remote-hostname**

Clears the outbound remote hostname and disables inbound remote host name matching on this net.

### **connection-direction [inbound] or [outbound] or [both]**

Specifies whether the connection can be initiated by the peer (inbound), the local device (outbound) or either the peer or the local device (both) on this net. If you specify both, you cannot specify zero for the idle time.

**Default value:** inbound

### **idle-time *seconds***

Specifies the number of seconds of inactivity after which L2 tunneling will disconnect the tunnel session on this net. A value of zero indicates that the tunnel is fixed and should not be disconnected.

**Valid range:** 0 to 1024

**Default value:** 0

### **remote-hostname *hostname***

Specifies the tunnel hostname of the peer.

For an outbound tunnel, the hostname specifies a tunnel profile configured in the AAA subsystem. This should be the tunnel hostname that the peer uses to identify itself.

For an inbound tunnel, only tunnel peers that identify themselves by this hostname can connect to this interface.

**Valid values:** Any name from 1 to 64 ASCII characters

**Default value:** *Name*

---

## Accessing the L2 Tunneling Feature Configuration Prompt

To access the L2 tunneling feature configuration prompt:

1. Enter **talk 6** at the OPCON (\*) prompt.
2. Enter **feature layer-2-tunneling** at the Config> prompt.

---

## L2 Tunneling Feature Configuration Commands

Table 52 summarizes the L2 tunneling feature configuration commands and the rest of this section explains the commands. Enter these commands at the Layer-2-Tunneling Config> prompt.

*Table 52. L2 Tunneling Feature Configuration Commands*

Command	Function
? (Help)	Displays all the commands available for this command level or lists the options for specific commands (if available). See "Getting Help" on page xxxii.
Add	Adds L2 tunneling nets and peers.
Disable	Disables L2 tunneling functions.
Enable	Enables L2 tunneling functions.
Encapsulator	Allows you to configure PPP parameters for all of the L2 tunneling nets that are not configured with a remote-hostname (ANY).
List	Displays information about the L2 tunneling configuration.
Set	Allows you to set buffers, the call receive window, and other L2 tunneling parameters.

## L2 Tunneling Feature Configuration Commands (Talk 6)

Table 52. L2 Tunneling Feature Configuration Commands (continued)

Command	Function
Exit	Returns you to the previous command level. See “Exiting a Lower Level Environment” on page xxxii.

### Add

Use the **add** command to add L2-Nets. One L2-Net is required for each concurrent PPP session that ends on this router. The end of a tunneled PPP session is the LNS end point of the tunnel.

#### Syntax:

add L2-nets

#### L2-nets

**Note:** This command can be entered entirely in lower case. The initial character is shown in upper case for clarity.

Adds L2-Nets to the L2 tunneling configuration. One L2-Net is required for each concurrent PPP session that is to be terminated at this router. If this router is to be used strictly as an LAC, no virtual L2-Nets are necessary. When you enter this command, you are prompted for the number of additional nets and whether to add unnumbered IP addresses for each L2 net.

The number of additional nets refers to how many nets are automatically added at this time. These nets are in addition to any L2-Nets that already exist.

Adding unnumbered IP addresses for each L2-Net automatically adds unnumbered IP entries into the IP routing table for each of the L2-Nets. Unnumbered IP addresses are the preferred mode of operation. If you need numbered addresses for the L2-Nets, you can alter them in the IP protocol configuration environment (refer to the chapter entitled “Configuring IP” in the *Protocol Configuration and Monitoring Reference Volume 1*).

### Disable

Use the **disable** command to disable L2 tunneling functions.

#### Syntax:

disable fixed-ip-source-address  
fixed-udp-source-port  
force-chap-challenge  
hiding-for-pap-attributes  
L2f  
L2tp  
pptp  
proxy-auth  
proxy-lcp



## L2 Tunneling Feature Configuration Commands (Talk 6)

sequencing

tunnel-auth

### **fixed-ip-source-address**

Causes the router to disable the specified source address.

### **fixed-udp-source-port**

Clears using a fixed UDP port. Disabling this parameter forces you to configure IP Security filters between the LAC and the LNS by IP address.

### **force-chap-challenge**

Disables the LNS CHAP rechallenge of a client. You might need to disable the CHAP rechallenge if the PPP client has difficulty with CHAP rechallenges.

### **hiding-for-pap-attributes**

Disables the encryption of Proxy PAP information between the LAC and LNS.

**L2f** Disables L2F protocol on this router.

**L2tp** Disables L2TP protocol on this router.

**pptp** Disables PPTP protocol on this router.

### **proxy-auth**

Disables sending PPP proxy-authentication from LAC to LNS.

### **proxy-lcp**

Disables sending LCP information from LAC to LNS.

### **sequencing**

Disables sequencing on the data channel.

### **tunnel-auth**

Disables tunnel peer authentication based on a shared secret for this router.

## Enable

Use the **enable** command to enable L2 tunneling functions.

### **Syntax:**

enable

fixed-ip-source-address

fixed-udp-source-port

force-chap-challenge

hiding-for-pap-attributes

L2f

L2tp

pptp

proxy-auth

proxy-lcp

sequencing

tunnel-auth

## L2 Tunneling Feature Configuration Commands (Talk 6)

### **fixed-ip-source-address**

Causes the router to reply with a source address equal to the inbound destination address.

### **fixed-udp-source-port**

Enabling this parameter allows you to configure IP Security filters by UDP port for L2 tunneling so you can encrypt or authenticate L2 tunneling traffic easily. Sets the UDP port at 1701 for L2TP.

### **force-chap-challenge**

Enables the LNS CHAP rechallenge of a client even if the LNS receives a proxy CHAP. This is preferable from a security standpoint, if it is known that the client can handle such a rechallenge without problems.

### **hiding-for-pap-attributes**

Enables the encryption of Proxy PAP information between the LAC and LNS.

**L2f** Enables L2F on this router.

**L2tp** Enables L2TP on this router.

**pptp** Enables PPTP on this router.

### **proxy-auth**

Enables sending PPP proxy-authentication from LAC to LNS.

### **proxy-lcp**

Enables sending LCP information from LAC to LNS.

### **sequencing**

Enables sequencing on the data channel.

### **tunnel-auth**

Enables tunnel peer authentication based on a shared secret for this router.

## Encapsulator

Use the **encapsulator** command to access the `ppp-L2tp config>` prompt in order to configure the PPP parameters for all Layer 2 Tunneling interfaces that are configured as inbound and `*any*` remote-hostname.

### **Syntax:**

**encapsulator**

## List

Use the **list** command to display the state of the various L2 tunneling configuration parameters.

### **Syntax:**

**list**

```
Layer-2-Tunneling Config>list  
GENERAL ADMINISTRATION
```

```
-----  
L2TP = Enabled  
L2F = Disabled  
PPTP = Disabled  
Maximum number of tunnels = 20  
Maximum number of calls (total) = 50  
Buffers Requested = 300
```

```
CONTROL CHANNEL SETTINGS  
-----
```



## L2 Tunneling Feature Configuration Commands (Talk 6)

### local-hostname

Specifies the hostname string identifying the local router that is sent in tunnel setup messages.

**Default value:** IBM

### max-calls

Specifies the maximum number of calls across all tunnels that can be active at a given time either as LAC or LNS.

**Valid range:** Depends on release:

Release	Range
R1	1 to 500
R2	1 to 2000

**Default value:** Depends on release:

Release	Default
R1	200
R2	300

### max-tunnels

Specifies the maximum number of tunnels that can be active at a given time either as LAC or LNS.

**Valid range:** Depends on release:

Release	Range
R1	1 to 500
R2	1 to 2000

**Default value:** Depends on release:

Release	Default
R1	200
R2	300

### transmit-retries

Specifies the number of times an L2TP packet is retransmitted on the control channel before the session or tunnel is declared inactive and is shut down.

**Valid range:** 2 to 100

**Default value:** 6

### tunnel-rcv-window

Specifies the L2TP receive window size for the reliable control connections transport. This transport transmits and receives the messages necessary for tunnel or session setup, tear down, and maintenance.

**Valid range:** 1 to 100

**Default value:** 4

---

## Accessing the L2 Tunneling Monitoring Prompt

To access the L2 tunneling monitoring prompt:

1. Enter **talk 5** at the OPCON (\*) prompt.
2. Enter **feature layer-2-tunneling** at the GWCON (+) prompt.

## L2 Tunneling Monitoring Commands

This section summarizes and then describes the L2 tunneling monitoring commands. Enter the commands at the Layer-2-Tunneling Console> prompt.

Table 53 summarizes the L2 tunneling monitoring commands.

Table 53. L2 Tunneling Monitoring Commands

Command	Function
? (Help)	Displays all the commands available for this command level or lists the options for specific commands (if available). See “Getting Help” on page xxxii.
Call	Displays statistics and information about each call in progress.
Kill	Ends a tunnel immediately.
Memory	Displays the current L2 tunneling buffer allocation and use.
Start	Starts a tunnel with another peer.
Stop	Stops a tunnel and allows each peer to perform any needed administration.
Tunnel	Displays statistics and information on each existing tunnel.
Exit	Returns you to the previous command level. See “Exiting a Lower Level Environment” on page xxxii.

## Call

Use the **call** command to display call statistics and information.

### Syntax:

```
call errors
      physical-errors
      queue
      state
      statistics
```

**errors** Displays the general transmission errors that occurred on the calls.

### Example:

```
Layer-2-Tunneling Console> call errors
CallID | Serial # | ACK-timeout | Dropped pkts
56744 | 1 | 0 | 0
```

**CallID** The local identifier associated with this call.

### Serial #

The number used for logging this call.

### ACK-timeout

The number of times a timeout notification has been received from the peer.

### Dropped pkts

The number of packets that have been declared lost for this call. These are packets which should have been received, but were signalled as lost by the peer.

### physical-errors

Displays the data errors that occurred on the calls.

### Example:

## L2 Tunneling Monitoring Commands (Talk 5)

```
Layer-2-Tunneling Console> call physical-errors
CallID | Serial# | CRC Errors | framing Errors | HW overrun | buffer overrun | timeout Errors | alignment | time since updated
56744 | 1 | 0 | 0 | 0 | 0 | 0 | 0 | 0
```

**CallID** The local identifier associated with this call.

**Serial #**

The number used for logging this call.

**CRC Errors**

The number of packets on which the CRC did not match.

**framing errors**

The number of packets with a framing error.

**HW overrun**

The number of times a hardware overrun occurred.

**buffer overrun**

The number of times a buffer overrun occurred.

**timeout errors**

The number of times an interface timed out.

**alignment**

The number of times an alignment error occurred.

**time since updated**

The elapsed time since last poll for errors.

**queue** Displays information about the queue for each call.

**Example:**

```
Layer-2-Tunneling Console> call queue
CallID | Serial # | Tx Win | Rx Win | Ns | Nr | Rx Q | Tx Q | priority | out Q
56744 | 1 | 4 | 4 | 100 | 200 | 0 | 0 | 0 | 0
```

**CallID** The local identifier associated with this call.

**Serial #**

The number used for logging this call.

**Tx Win**

The peer's maximum receive window for data.

**Rx Win**

The local maximum transmit window.

**Ns**

The next packet sequence number to send for this call.

**Nr**

The next packet sequence number expected to be received for this call.

**Rx Q**

The current number of packets on the receive queue.

**Tx Q**

The current number of packets on the transmit queue.

**priority**

The number of priority PPP packets waiting to be transmitted by L2TP.

**out Q**

The number of regular PPP packets waiting to be transmitted by L2TP.

**state** Displays the current state of each call.

**Example:**

## L2 Tunneling Monitoring Commands (Talk 5)

```
Layer-2-Tunneling Console> call state
CallID | Serial # | Net # | State | Time Since Chg | PeerID | TunnelID
56744 | 1 | 2 | Established | 00:00:00 | 345 | 45678
```

**CallID** The local identifier associated with this call.

**Serial #**

The number used for logging this call.

**Net #** The device number associated with this call. For an LNS call, this is the L2-Net. For an LAC call, this is the PPP device that received the initial call.

**State** The current call state. Valid call states are:

**Established**

Ready for tunneled network traffic.

**Idle** The call is idle.

**Wait Cs Answer**

Waiting for the communication link to open.

**Wait Reply**

Waiting for a reply from the peer.

**Wait Tunnel**

Waiting for tunnel establishment.

**Time since chg**

The elapsed time since the last state change.

**PeerID**

The Peer's call ID.

**TunnelID**

The local tunnel associated with this call.

### statistics

Displays statistics about the data transmission for each call.

**Example:**

```
Layer-2-Tunneling Console> call statistics
CallID | Serial # | Tx Pkts | Tx Bytes | Rx Pkts | Rx Bytes | RTT | ATO
56744 | 1 | 34 | 1056 | 45 | 1567 | 10 | 34
```

**CallID** The local identifier associated with this call.

**Serial #**

The number used for logging this call.

**Tx Pkts**

The number of packets transmitted for this call.

**Tx Bytes**

The number of bytes transmitted for this call.

**Rx Pkts**

The number of packets received for this call.

**Rx Bytes**

The number of bytes received for this call.

**RTT** The currently calculated round trip time for this call.

**ATO** The currently calculated adaptive time out for this call.

## L2 Tunneling Monitoring Commands (Talk 5)

### Kill

Use the **kill** to immediately end a tunnel. This command releases all of the local resources for a tunnel thereby forcing the end of the connection. No notification of the end of the tunnel is sent to the peer.

**Note:** Use this command only if the **stop** command is unable to end a tunnel.

**Syntax:**

kill *tunnel tunnelid*

**tunnel** *tunnelid*

Specifies the tunnel to end.

### Memory

Use the **memory** command to display L2TP's current memory utilization.

**Syntax:**

memory

**Example:**

```
Layer-2-Tunneling Console> mem
Number of layer-2-tunneling buffers: Requested = 2000, Total = 1200, Free = 1000
```

In this example, you configured 2000 buffers but were able to allocate only 1200. Currently, 200 buffers are in use leaving 1000 free.

### Start

Use the **start** command to start a tunnel with another peer.

**Syntax:**

start **tunnel** *hostname*

(no parameters prompts you for hostname)

**tunnel** *hostname*

The name of the host with which L2T establishes the tunnel.

### Stop

Use the **stop** command to stop a tunnel. Any required cleanup is completed before the tunnel ends.

**Syntax:**

stop *tunnel tunnelid*

**tunnel** *tunnelid*

Specifies the tunnel to end.

### Tunnel

Use the **tunnel** command to display statistics and information about all tunnels.

**Syntax:**

tunnel call  
errors



## L2 Tunneling Monitoring Commands (Talk 5)

peer

queue

state

statistics

transport

**calls** Displays all tunnels and the call state for each call within each tunnel.

**errors** Displays the errors that have occurred on a tunnel.

### Example:

```
Layer-2-Tunneling Console> tunnel errors
Tunnel ID | Type | ACK-timeouts
96785     | L2TP | 0
43690    | PPTP | 2
96785    | L2F  | 0
```

### Tunnel ID

The local identifier associated with a tunnel.

**Type** The type of tunneling protocol being used.

### ACK-timeouts

The number of times a timeout notification has been received from the peer.

**peer** Displays the tunnels and the peers associated with the tunnels.

### Example:

```
Layer-2-Tunneling Console> tunnel peer
Tunnel ID | Type | Peer ID | Peer Hostname
96785     | L2TP | 89777   | peer1
11264    | L2F  | 46538   | peer2
34653    | L2F  | 11209   | peer3
87511    | PPTP | 55377   | peer4
```

### Tunnel ID

The local identifier associated with a tunnel.

**Type** The type of tunneling protocol being used.

### Peer ID

The peer's tunnel identifier assigned to this tunnel.

### Peer Hostname

The hostname of the peer as it appears in the local database.

**queue** Displays information about the queue for each tunnel.

### Example:

```
Layer-2-Tunneling Console> tunnel queue
Tunnel ID | Type | Rx Win | Tx Win | Ns | Nr | Rx Q | Tx Q
96785     | L2TP | 4       | 4       | 5  | 6  | 0     | 0
76488    | L2F  | 4       | 4       | 5  | 6  | 0     | 0
22209    | PPTP | 4       | 4       | 5  | 6  | 0     | 0
```

### Tunnel ID

The local identifier associated with a tunnel.

**Type** The type of tunneling protocol being used.

### Rx Win

The local maximum number of packets that constitute the receive window.

### Tx Win

The peer's maximum number of packets that constitute the receive window.

## L2 Tunneling Monitoring Commands (Talk 5)

**Ns** The sequence number of the next packet to send.

**Nr** The sequence number of the next packet to receive.

**Rx Q** The number of packets currently on the receive queue.

**Tx Q** The number of packets currently on the transmit queue.

**state** Displays the current state of all the tunnels.

### Example:

```
Layer-2-Tunneling Console> tunnel state
Tunnel ID | Type | Peer ID | State | Time Since Chg | # Calls | Flags
17404     | PTP  | 0       | Established | 00:00:00 | 1 | 0
96785     | L2TP | 0       | Established | 00:02:05 | 2 | 0
38237     | L2F  | 0       | Established | 00:00:00 | 1 | 0
```

### Tunnel ID

The local identifier associated with a tunnel.

**Type** The type of tunneling protocol being used.

### Peer ID

The peer's tunnel identifier assigned to this tunnel.

**State** The current tunnel state. Valid tunnel states are:

#### Established

The tunnel is established.

#### Idle

The tunnel is idle.

#### Wait Ctrl Reply

The host is waiting for a reply from the peer.

#### Wait Ctrl Conn

The host is waiting for a connection indication.

### Time since chg

The elapsed time since the last state change.

### # Calls

The number of active calls on this tunnel.

**Flags** The flags used to control the connection messages on this tunnel.

### statistics

Displays the statistics associated with the tunnels.

### Example:

```
Layer-2-Tunneling Console> tunnel statistics
Tunnel ID | Type | Tx Pkts | Tx Bytes | Rx Pkts | Rx Bytes | RTT | ATO
96785     | L2TP | 4       | 78       | 5       | 89       | 10 | 31
96366     | L2F  | 9344    | 34578    | 305     | 4300     | 10 | 31
12344     | PTP  | 24      | 478      | 115     | 2745     | 10 | 31
```

### Tunnel ID

The local identifier associated with a tunnel.

**Type** The type of tunneling protocol being used.

### Tx Pkts

The number of packets transmitted.

### Tx Bytes

The number of bytes transmitted.

### Rx Pkts

The number of packets received.

## L2 Tunneling Monitoring Commands (Talk 5)

### Rx Bytes

The number of bytes received.

**RTT** The currently calculated round trip time for tunnel control connection messages.

**ATO** The currently calculated adaptive timeout for tunnel control connection messages.

### transport

Displays UDP information about the tunnels.

#### Example:

```
Layer-2-Tunneling Console> tunnel transport
Tunnel ID | Type | Peer IP Address | UDP Src | UDP Dest
96785     | L2TP | 11.0.0.102     | 1056   | 1089
30000     | L2F  | 11.0.0.104     | 1058   | 1090
45772     | PPTP | 11.4.4.027     | 1345   | 1020
```

### Tunnel ID

The local identifier associated with a tunnel.

**Type** The type of tunneling protocol being used.

### Peer IP address

The peer's IP address for this tunnel.

### UDP Src

The UDP source port for this tunnel.

### UDP Dest

The UDP destination port for this tunnel.

---

## L2 Tunneling Dynamic Reconfiguration Support

This section describes dynamic reconfiguration (DR) as it affects Talk 6 and Talk 5 commands.

### CONFIG (Talk 6) Delete Interface

Layer 2 Tunneling supports the CONFIG (Talk 6) **delete interface** command with no restrictions.

### GWCON (Talk 5) Activate Interface

Layer 2 Tunneling supports the GWCON (Talk 5) **activate interface** command with the following consideration:

There are no additional limitations over other PPP interfaces.

All Layer 2 Tunneling configuration changes are automatically activated except the following:

Commands whose changes are not activated by the GWCON (Talk 5) activate interface command
---

CONFIG, net, enable ccp
-------------------------

<b>Note:</b> Compression will not be enabled if this is the first PPP net with CCP enabled.
---

CONFIG, net, set lcp options (mru option)
---

<b>Note:</b> The MRU value will not be set higher than the buffer size allocated for the router at reboot.
--

## L2 Tunneling Monitoring Commands (Talk 5)

### GWCON (Talk 5) Reset Interface

Layer 2 Tunneling supports the GWCON (Talk 5) **reset interface** command with the following consideration:

There are no additional limitations over other PPP interfaces.

All Layer 2 Tunneling configuration changes are automatically activated except the following:

Commands whose changes are not activated by the GWCON (Talk 5) reset interface command
--

CONFIG, net, enable ccp
-------------------------

<b>Note:</b> Compression will not be enabled if this is the first PPP net with CCP enabled.
---

CONFIG, net, set lcp options (mru option)
---

<b>Note:</b> The MRU value will not be set higher than the buffer size allocated for the PPP interface at reboot.
---

### CONFIG (Talk 6) Immediate Change Commands

Layer 2 Tunneling supports the following CONFIG commands that immediately change the operational state of the device. These changes are saved and are preserved if the device is reloaded, restarted, or you execute a dynamically reconfigurable command.

Commands
----------

CONFIG, feature layer-2-tunneling, disable fixed-ip-source-address
--

CONFIG, feature layer-2-tunneling, disable fixed-udp-source-port
--

CONFIG, feature layer-2-tunneling, disable force-chap-challenge
---

CONFIG, feature layer-2-tunneling, disable hiding-for-pap-attributes
--

CONFIG, feature layer-2-tunneling, disable proxy-auth
---

CONFIG, feature layer-2-tunneling, disable proxy-lcp
--

CONFIG, feature layer-2-tunneling, disable sequencing
---

CONFIG, feature layer-2-tunneling, disable tunnel-auth
--

CONFIG, feature layer-2-tunneling, enable fixed-ip-source-address
---

CONFIG, feature layer-2-tunneling, enable fixed-udp-source-port
---

CONFIG, feature layer-2-tunneling, enable force-chap-challenge
--

CONFIG, feature layer-2-tunneling, enable hiding-for-pap-attributes
---

CONFIG, feature layer-2-tunneling, enable proxy-auth
--

CONFIG, feature layer-2-tunneling, enable proxy-lcp
---

CONFIG, feature layer-2-tunneling, enable sequencing
--

CONFIG, feature layer-2-tunneling, enable tunnel-auth
---

CONFIG, feature layer-2-tunneling, set error-check-period
---

CONFIG, feature layer-2-tunneling, set host-lookup-password
---

CONFIG, feature layer-2-tunneling, set local-hostname
---

CONFIG, feature layer-2-tunneling, set transmit-retries
---

CONFIG, feature layer-2-tunneling, set tunnel-rcv-window
--

CONFIG, add tunnel-profile
----------------------------

### Non-Dynamically Reconfigurable Commands

The following table describes the Layer 2 Tunneling configuration commands that cannot be dynamically changed. To activate these commands, you need to reload or restart the device.

Commands
CONFIG, feature layer-2-tunneling, enable l2f
CONFIG, feature layer-2-tunneling, enable l2tp
CONFIG, feature layer-2-tunneling, enable pptp
CONFIG, feature layer-2-tunneling, disable l2f
CONFIG, feature layer-2-tunneling, disable l2tp
CONFIG, feature layer-2-tunneling, disable pptp
CONFIG, feature layer-2-tunneling, set buffers
CONFIG, feature layer-2-tunneling, set max-calls
CONFIG, feature layer-2-tunneling, set max-tunnels

## L2 Tunneling Monitoring Commands (Talk 5)

---

## Chapter 28. Using Network Address Translator

Network Address Translator (NAT) and its extension Network Address and Port Translator (NAPT) can expand the number of IP addresses available to an organization and can prevent users in the public network from becoming aware of some of the addresses in the private network. NAT works by using public IP addresses to represent private IP addresses.

Public IP addresses are the valid addresses of hosts in the IP public network and they must be unique within the public network. If the public network is the Internet, the public IP addresses must be unique Internet addresses provided by the Network Information Center (NIC).

The private addresses are known to the router, but not to the public network. The addresses within each private network must be unique; however, the same address can be duplicated in two different private networks. The private addresses are assigned to hosts within stub networks. Stub networks are networks that have access to the public network through one router only.

NAT expands the number of available IP addresses in several ways:

- It allows each public address to represent multiple private addresses by rotating the use of the public addresses.
- It allows the duplication of addresses as long as each duplicate address is used in a different private network.
- It allows the network administrator to use any IP addresses in the private networks, instead of the NIC addresses that are becoming limited resources.

Using private addresses also hides these addresses from the outside world. This feature of NAT makes it useful as a type of firewall to protect the private addresses from being known.

**Important:** As stated in section 5.4 of the Internet Draft which defines NAT, “any application that carries (and uses) the IP address (and TCP/UDP port, in the case of NAPT) inside the application will not work through NAT...”. It should be noted that DLSw and XTP make decisions based on the end-point IP addresses — specifically which partner has the higher address. Since the application (such as DLSw or XTP) that is running through NAT thinks that its address is the private address, but the partner application in the other router thinks that the application’s address is the public address, incorrect decisions can be made.

See Figure 44 on page 446 for a drawing of a workstation in a stub network. In this example, the stub network consists of an IP subnet that has the IP address 10.33.96.0 with the subnet mask 255.255.255.0.

## Using Network Address Translator

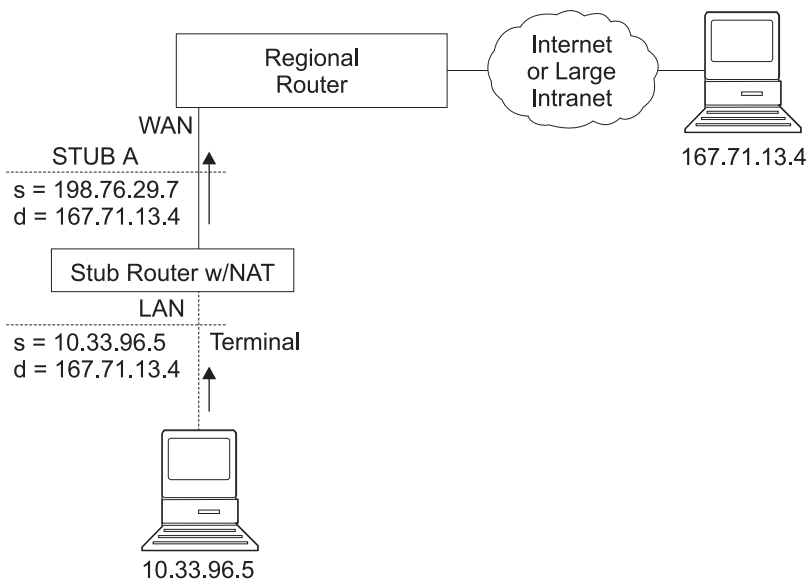

Figure 44. Network Running NAT

To use NAT, the network administrator assigns one or more public IP addresses to a public address pool in the 2212 and assigns a private IP address to each workstation in the stub network. The public IP addresses are assigned to a *reserve pool* and the private IP addresses are assigned to the *translate range*.

The NAT function first binds the private address of a station in the private network to one of the public addresses. Binding means that every packet with that private address will be translated to that public IP address when the packet is outbound. Inbound packets have the public IP address as their destination. NAT recognizes the public address, translates it to the private IP address, and forwards the packet. After traffic stops, the binding is maintained until a timer that you can set times out. At this time, NAT ends the binding and makes the public address available for reuse.

In this example, a packet is transmitted from sending private source address 10.33.96.5 to a destination address in the Internet, 167.71.13.4. NAT in the 2212 translates private address 10.33.96.5 to public address 198.76.29.7. This translation hides the private address 10.33.96.5 from the public network, so that no incoming packet is addressed directly to private address 10.33.96.5. Instead, incoming packets from 167.71.13.4 are addressed to public address 198.76.29.7. When the NAT router receives packets addressed to 198.76.29.7, NAT translates the destination public address to the private address 10.33.96.5 and forwards the packets.

---

## Network Address Port Translator

NAPT can be used only for TCP and UDP traffic. In NAPT, multiple private addresses can use a single public address simultaneously. While NAT maps one public address to one private address, NAPT maps the NAPT public address **and** the public port number to a private address and private port number. Only one NAPT address can be configured for each public address pool.

NAPT is configured simply by specifying one public address or a Dynamic-Address interface (which is using PPP/IPCP to retrieve a public address) that will be used



for NAT traffic. The advantage of NAT is that it can enable one address from the pool of public IP addresses to support many private IP addresses simultaneously.

---

## Static Address Mappings

Sometimes you may want to configure a station or server in the private network that can be directly accessed from the public network. In this case, you should make a static mapping of the private address of the station to a particular public address. All messages outbound from the private address are translated to the designated public address and all messages inbound for the designated public address are automatically forwarded to the associated private address. There are two kinds of static address mappings: NAT and NAT.

### NAT Static Address Mapping

In a NAT mapping, all IP protocols can access the host. This is an example of the configuration of a NAT mapping:

Private address	10.1.1.2
Private port	0
Public NAT address	9.67.1.1
Public port	0

### NAPT Static Address Mapping

To specify a TCP or UDP application, you have the option to specify a NAPT mapping that includes a private well-known port. For NAPT static address mapping, a NAPT public address must be configured. For example, to configure a Telnet host at private address 10.1.1.1 to use the NAPT public address 9.67.1.2, the static mapping would be configured as follows:

Private address	10.1.1.1
Private port	23
Public NAPT address	9.67.1.2
Public port	23

The private and public ports are mapped to port 23, which is the well-known port for Telnet. Now, if the administrator also has an FTP server (well-known address 21) at the same private address 10.1.1.1 to map to the NAPT public address 9.67.1.2, that mapping can look like this:

Private address	10.1.1.1
Private port	21
Public NAPT address	9.67.1.2
Public port	21

The server at address 10.1.1.1 has the same NAPT public address (9.67.1.2) for both applications, but NAPT can distinguish between the two by using the different port numbers (23 and 21). However, NAPT cannot distinguish between two servers that use the same NAPT public address and have the same application and port number. For example, if the NAPT public address and well-known port are the same for 10.1.1.3 port 21 as for 10.1.1.1 port 21, NAPT cannot tell whether to send incoming FTP traffic to server 10.1.1.3 or 10.1.1.1. To configure more than one

## Using Network Address Translator

server with the same NAT address and application, you must use a port other than the well-known port at the server (for example, start the FTP daemon on port 200).

---

## Setting Packet Filters and Access Control Rules for NAT

In addition to identifying the range of private addresses to be translated by NAT or NAT, the administrator must set up packet filters and access control rules for IP in the 2212. NAT configuration requires you to configure one inbound and one outbound packet filter on the interface that is connected to the public network. You need to configure one or more access control rules on the inbound packet filter and one or more access control rules on the outbound packet filter. The inbound filter access control rules pass inbound packets with the appropriate defined public addresses to NAT. The outbound filter access control rules pass outbound packets with the appropriate defined private addresses to NAT.

The access control rules that are applied for NAT have the access control rule types *I* and *N* for inclusive and NAT. Refer to the *Protocol Configuration and Monitoring Reference Volume 1* for information about configuring IP access controls.

**Note:** NAT can also be configured in conjunction with an IPsec tunnel. A sample of this configuration is found in “Configuring Packet Filter Access Control Rules for Router A” on page 374.

## Example: Configuration of NAT With IP Filters and Access Control Rules

This example shows how to configure NAT for the stub router in the network pictured in Figure 45. See “Chapter 29. Configuring and Monitoring Network Address Translator” on page 451 for descriptions of the commands. Follow this procedure:

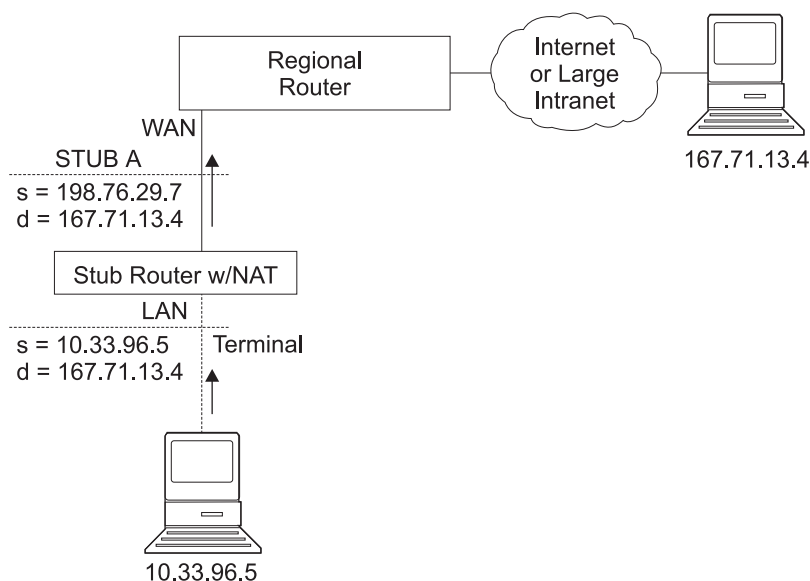

Figure 45. Network Running NAT

1. Set up pools of public addresses for use by NAT and NAT. To do this, use the **reserve** command.

```
NAT config> reserve No 198.76.29.7 255.255.255.0 6 pool1 198.76.29.7
NAT config> reserve No 198.76.29.15 255.255.255.0 3 pool1 0.0.0.0
```

## Using Network Address Translator

In this example, a pool called *pool1* is established. The NAPT address in the pool is 198.76.29.7. The addresses 198.76.29.13 and 198.76.29.14 are not available, so the pool is set up to exclude them. The parameters entered are: *public-address, mask, number-in-group, name, and napt-address*. The value 0.0.0.0 for the NAPT address means that none of the addresses in this group is the NAPT address. Use 0.0.0.0 for the NAPT address in all groups if you do not configure NAPT for the pool.

2. Use the **translate** command to establish the ranges of private addresses to be translated by the public addresses in pool1. The parameters entered are: *private-address, mask, and name*.

```
NAT config> translate 10.33.96.0 255.255.255.0 pool1
```

3. Set up static mappings for stations inside the private network that are to be permanently mapped to one of the public addresses. The following commands identify one machine (10.33.96.5) that will receive any type of traffic from the public network. A second machine (10.33.96.4) is both a Telnet and an HTTP server. The parameters are *private-address, private-port-number, public-address, and public-port-number*. Note that the NAPT address for pool1 is used as the public address for the host that is configured with two port numbers.

```
NAT config> map 10.33.96.5 0 198.76.29.8 0
NAT config> map 10.33.96.4 23 198.76.29.7 23
NAT config> map 10.33.96.4 80 198.76.29.7 80
```

4. Enable NAT.

```
NAT config> enable NAT
```

5. Create two IP packet filters so that IP will pass packets to NAT. These are inbound and outbound packet filters for interface 0, which is the interface connected to the public network.

```
IP Config> add packet-filter outbound out-0 0
IP Config> add packet-filter inbound in-0 0
```

6. Use the **update** command to bring up the packet-filter '*filter-name*' Config> prompt. Add an access control rule for NAT to the inbound filter. Packets received over the public interface (net 0) that are destined for an address in NAT's reserved public address pool should be passed to NAT. NAT will replace the public address (and the public port if the packet is destined for the NAPT address) with the correct private address (and the private port if the packet is destined for the NAPT address). The 0.0.0.0 address and mask for the Internet source indicate that any source addresses from the public network will be passed to NAT.

```
IP Config>update packet-filter
Packet-filter name [ ]? in-0
Packet-filter 'in-0' Config> add access
Enter type [E]? IN
Internet source [0.0.0.0]?
Source mask [255.255.255.255]? 0.0.0.0
Internet destination [0.0.0.0]? 198.76.29.0
Destination mask [255.255.255.255]?255.255.255.0
Enter starting protocol number ([0] for all protocols) [0]?
Enable logging? (Yes or [No]):
Packet-filter 'in-0' Config>
```

The range of addresses in the access control rule is greater than the range of addresses defined in pool1. If the address of the packet passed to NAT is in the range defined in the access control rule but is not one of the ones in the public address pool, NAT passes the packet back to IP unchanged.

7. If you wish the router to pass the packets that do not match the access control rule, rather than drop them, you can create a wildcard access control rule. The following example shows such an access control rule:

## Using Network Address Translator

```
Packet-filter 'in-0' Config> add access
Enter type [E]? I
Internet source [0.0.0.0]? 0.0.0.0
Source mask [255.255.255.255]? 0.0.0.0
Internet destination [0.0.0.0]? 0.0.0.0
Destination mask [255.255.255.255]?0.0.0.0
Enter starting protocol number ([0] for all protocols) [0]?
Enable logging? (Yes or [No]):
Packet-filter 'in-0' Config>
```

8. Add an access control rule for NAT to the outbound packet filter. Packets to be forwarded from the net 0 interface that have a source address on the private network are identified so that IP can pass them to NAT. NAT replaces the private address with one of the public addresses in pool1.

```
Packet-filter 'out-0' Config> add access
Enter type [E]? IN
Internet source [0.0.0.0]? 10.33.96.0
Source mask [255.255.255.255]? 255.255.255.0
Internet destination [0.0.0.0]?
Destination mask [255.255.255.255]?0.0.0.0
Enter starting protocol number ([0] for all protocols) [0]?
Enable logging? (Yes or [No]):
Packet-filter 'out-0' Config>
```

With this packet filter as with filter *in-0*, you can add a wildcard inclusive access control rule as the last access control rule if you plan to forward packets that do not match the access control rule.

9. You can use the **list packet-filter** *filter-name* command from the IP Config> prompt to check the accuracy and sequence of the access control rules in each packet filter.
10. Enable the access controls for IP.
11. Reset IP and NAT using talk 5. Until now, you have created changes in the router configuration, but these changes have not affected the router. The reset commands for IP and NAT cause the router to read in the new configuration and run with the rules defined in the configuration.

```
NAT> reset NAT
IP> reset IP
```

---

## Chapter 29. Configuring and Monitoring Network Address Translator

This chapter describes the Network Address Translator (NAT) configuring and monitoring commands and includes the following sections:

- “Accessing the Network Address Translator Configuration Environment”
- “Network Address Translator Configuration Commands”
- “Accessing the Network Address Translator Monitoring Environment” on page 457
- “Network Address Translator Monitoring Commands” on page 458
- “NAT Dynamic Reconfiguration Support” on page 459

---

### Accessing the Network Address Translator Configuration Environment

To access the NAT configuration environment, enter the following command at the Config> prompt:

```
Config> feature nat
Network Address Protocol user configuration
NAT config>
```

---

### Network Address Translator Configuration Commands

This section explains the Network Address Translator (NAT) configuration commands. To configure NAT, enter these commands at the NAT config> prompt.

*Table 54. NAT Configuration Commands*

Command	Function
? (Help)	Displays all the commands available for this command level or lists the options for specific commands (if available). See “Getting Help” on page xxxii.
Change	Changes public IP address reserve pools, private address translate ranges, and static mappings.
Delete	Deletes public IP address reserve pools, private address translate ranges, and static mappings.
Disable	Disables NAT.
Enable	Enables NAT.
List	Lists information about the NAT configuration.
Map	Creates a static NAT or NAPT binding for a station or server.
Reserve	Creates a public IP address pool and appends addresses to that pool.
Reset	Causes the router to read in the NAT configuration and run according to the NAT rules that have been configured.
Set	Sets timeouts.
Translate	Identifies the private IP addresses to be translated by the NAT public address pool.
Exit	Returns you to the previous command level. See “Exiting a Lower Level Environment” on page xxxii.

#### Change

Use the **change** command to change public IP address reserve pools, private IP address translate ranges, and static mappings.

**Syntax:**

```
change                _reserve
                        _translate
```

## Configuring Network Address Translator (Talk 6)

### mappings

#### **reserve** *pools*

Provides prompts that enable you to change characteristics of any of the public IP address reserve pools (such as IP addresses and masks) .

**Valid Values:** An index number to identify the configured pool. This number is displayed when you enter the **list reserve pools** command.

**Default Value:** none

#### **translate** *ranges*

Provides prompts that enable you to change characteristics of any of the private IP address translate ranges (such as IP addresses and masks).

**Valid Values:** An index number to identify the configured translate range. This number is displayed when you enter the **list translate** command.

**Default Value:** none

#### **mappings**

Provides prompts that enable you to change characteristics of any of the static address mappings (such as IP addresses and ports).

**Valid Values:** An index number to identify the configured mapping. This number is displayed when you enter the **list mappings** command.

**Default Value:** none

## Delete

Use the **delete** command to delete public IP address reserve pools, private IP address translate ranges, and mappings.

### **Syntax:**

```
delete                reserve  
                        translate  
                        mappings
```

#### **reserve** *pools*

Provides prompts that enable you to delete any of the public IP address reserve pools.

**Valid Values:** An index number to identify the configured pool. This number is displayed when you enter the **list reserve pools** command.

**Default Value:** none

#### **translate** *ranges*

Provides prompts that enable you to delete any of the private IP address translate ranges.

**Valid Values:** An index number to identify the configured translate range. This number is displayed when you enter the **list translate** command.

**Default Value:** none

#### **mappings**

Provides prompts that enable you to delete any of the static address mappings.

**Valid Values:** An index number to identify the configured mapping. This number is displayed when you enter the **list mappings** command.

## Configuring Network Address Translator (Talk 6)

**Default Value:** none

### Disable

Use the **disable** command to disable NAT. You can disable NAT so that it will drop packets requiring translation or you can disable NAT so that it will pass packets requiring translation.

**Syntax:**

**disable nat**

drop

pass

**drop** Disables NAT so that it drops packets requiring translation.

**pass** Disables NAT so that it passes packets requiring translation.

### Enable

Use the **enable** command to enable NAT. Enabling NAT makes it ready to run, but it will not run until you use the **reset** command or restart the router.

**Syntax:**

**enable nat**

### List

Use the **list** command to list the public IP address reserve pools, the private IP address translate ranges, the mappings, the global settings, or all the NAT information.

**Syntax:**

**list**

reserve

addresses

pools

translate

mappings

global

all

In the following example, times are displayed as hours, minutes, and seconds. Entry age is the time elapsed since the entry was last used. A binding means that traffic is flowing between these two addresses. The timeouts determine how much time will elapse after the last communication before a binding is dropped. See the **set** command for more information about timeouts.

**Example:**

```
NAT config>list all
NAT Globals:
NAT is ENABLED
Tcp Timeout....: 24:00:00
Non-Tcp Timeout: 0:01:00
NAT Reserved Address Pool(s):
Index First Address Mask Count NAPT Address Pool Name
1 9.8.7.1 255.255.255.0 3 0.0.0.0 pool1
2 9.8.7.6 255.255.255.0 12 9.8.7.9 pool1
```

## Configuring Network Address Translator (Talk 6)

```
NAT Translate Range(s):
Index IP Address      IP Mask      Associated Pool Name
1     7.1.1.0          255.255.255.0 pool1
2     10.0.0.0          255.0.0.0    pool1
NAT Static Mapping(s):
Index Private Address:Port  Public Address.:Port
1     10.1.2.3             0      9.8.7.1      0
2     7.1.1.1             21     9.8.7.9      21
```

## Map

Use the **map** command to statically bind a host or server in the private network to a public address. This command, which can be used to set up servers in the private network, establishes an association at NAT startup that never changes.

Static mappings with the public and private port number 0 are NAT mappings; those with other values for the port numbers are NAPT mappings.

### Syntax:

```
map private-address private-port-number public-address
public-port-number
```

### **private-address**

The private address of the workstation.

**Valid Values:** an Internet host address in valid IP format. This should be the address assigned to a station in the stub network that requires permanent access from the public network, such as a server.

**Default Value:** none

### **private-port-number**

The TCP/UDP port number of the application running in the device with the private address. Entering **0** creates a NAT binding and entering another value creates a NAPT binding. Common port values for NAPT are 23 for Telnet, 21 for FTP, and 80 for HTTP.

**Valid Values:** 0 - 65535

**Default Value:** 0

### **public-address**

The public IP address to which this private address is to be mapped. This must be a NAPT address for a NAPT mapping and a NAT address for a NAT mapping.

**Valid Values:** a valid IP address unique to the public network. The public network can be the Internet or an intranet, depending upon the design of the network.

**Default Value:** none

### **public-port-number**

The port number of the packets to be translated at the public address. The value 0 represents all ports. Common values are 23 for Telnet, 21 for FTP, and 80 for HTTP.

**Valid Values:** 0 - 65535

**Default Value:** 0

In this example, the server with private IP address 10.11.12.200 accepts all traffic from the Internet; the server with private address 10.11.12.199 is a Telnet server and an FTP server.



### Example:

```
map 10.11.12.200 0 9.8.7.2 0
map 10.11.12.199 23 9.8.7.9 23
map 10.11.12.199 21 9.8.7.9 21
```

## Reserve

Use the **reserve** command to create and append a range of IP addresses to a public address pool. Additionally, it can be used to append a Dynamic IP interface to the public address pool.

### Syntax:

**reserve** *dynamic [interface][public-address][mask][number-in-group] name [napt-address]*

**Note:** The values shown in brackets are now optionally displayed.

- **Dynamic** - Specifies if this entry is for a group of public addresses or for a Dynamic-Address interface that will retrieve its IP address from a PPP connection that is using IPCP. Valid values are *yes* or *no*. The default is *no*. If *Dynamic=yes*, then you only need to specify the interface and name. If *Dynamic=no*, you do not specify interface, but you must specify all the other values.
- **Interface** - Specifies the Dynamic-Address interface as configured within IP. Any valid interface number can be specified. The default is zero.

### public-address

The first public IP address in the sequence of addresses that make up this range or group in the pool. For example, if this group in the pool includes the 12 addresses in sequence from 9.8.7.6 through 9.8.7.17, this value is 9.8.7.6.

**Note:** To add another range of addresses to the public address pool, use the **reserve** command separately for each group, relating one group to another by using the same pool name. For example, addresses 9.8.7.6 through 9.8.7.17 can be configured in one group within pool1 and addresses 9.8.7.1 through 9.8.7.3 can be configured in another group within the same pool. Then, addresses 9.8.7.4 and 9.8.7.5 are not configured or used by that pool.

**Valid Values:** a valid IP address that is unique to the public network

**Default Value:** none

**mask** A mask to select bits from the IP address. The mask, like an Internet address, is 32 bits long. The 1s in the mask select the network or subnet part of the address. The 0s select the host portion. For example, the address 9.8.7.6 and the mask 255.255.0.0 includes the range of all addresses of which the first two bytes are 9.8 (that is, 9.8.0.0 through 9.8.255.255).

**Valid Values:** any valid IP mask

## Configuring Network Address Translator (Talk 6)

**Default Value:** none

### **number-in-group**

Specifies how many sequential addresses, beginning with the *public-address*, are included in the group. For the addresses 9.8.7.6 through 9.8.7.17, this value is 12.

**Valid Values:** 1 - the value that can be defined by the IP mask

**Default Value:** none

**name** The name of the public address reserve pool. This string has to match the pool name on the corresponding **translate** command.

**Valid Values:** any name, using up to 16 printable characters; leading and trailing blanks are ignored.

**Default Value:** none

### **napt-address**

The one IP address from the public address pool that will be used by Network Address Port Translation (NAPT). This address is used for TCP and UDP traffic to map multiple private addresses to the one NAPT address according to the protocol port number. Using NAPT is optional. If it is used, there can be only one NAPT address per public address pool. If there is no NAPT address for a pool or group, enter the value **0.0.0.0**. You need only enter the NAPT address once for the pool.

**Valid Values:** one of the public IP addresses. It does not necessarily have to be included in the range of values defined in the public address pool, but it must be in the same subnet.

**Default Value:** 0.0.0.0 (meaning no NAPT)

### **Example:**

```
reserve no 9.8.7.1 255.255.255.0 3 pool1 0.0.0.0
reserve no 9.8.7.6 255.255.255.0 12 pool1 9.8.7.9
reserve yes 2 dynamic_ip_pool
```

## Reset

Use the **reset** command to reset NAT. This command deletes all bindings, frees all memory used by NAT, and restarts NAT based on the current Talk 6 configuration. Resetting NAT does not disrupt any other components of the 2212.

### **Syntax:**

**reset nat**

Note that if NAT encounters an invalid configuration, you will see a message to that effect. Review the NAT ELS messages to see why NAT initialization failed.

## Set

Use the **set** command to set TCP and non-TCP timeouts.

### **Syntax:**

**set** tcp nontcp

**tcp timeout**

The time that NAT maintains a TCP binding after the last message passes

## Configuring Network Address Translator (Talk 6)

between the two bound workstations. A binding is the maintenance of the relationship between a private address and one of the public IP addresses.

**Valid Values:** 0 - 65535 minutes (0 minutes to about 45 days)

**Default Value:** 1440 minutes (24 hours)

### **nontcp** *timeout*

The time that NAT maintains a binding that is not TCP after the last message passes between the two bound stations. A binding is the maintenance of the relationship between a private address and one of the public IP addresses.

**Valid Values:** 0 - 65535 minutes (0 minutes to about 45 days)

**Default Value:** 1 minute

## Translate

Use the **translate** command to add a subnet to the list of addresses that NAT will translate. Each subnet is a translate range. This command must be entered once for each translate range that NAT must know. Any number of translate ranges can use a single public address reserve pool.

### **Syntax:**

**translate** *private-address mask name*

### **private-address**

Any IP host or subnet address that should be translated.

**Valid Values:** an address in valid dotted decimal IP format. When ANDed with its subnet mask, this address identifies all addresses in a stub subnet. A stub subnet is a network that accesses the public network only through the router.

**Default Value:** none

**mask** **Valid Values:** The network or subnet mask associated with the stub network to be translated.

**Default Value:** class mask of the private address

**name** The name of the public address pool NAT should use for this range of private addresses.

**Valid Values:** any name, using up to 16 printable characters. It must match a public address pool name created by the **reserve** command.

**Default Value:** none

---

## Accessing the Network Address Translator Monitoring Environment

To access the NAT monitoring environment, type

```
* t 5
```

Then, enter the following command at the + prompt:

```
+ feature NAT
NAT>
```

The NAT> prompt appears.

## Network Address Translator Monitoring Commands

This section describes the IP Security monitoring commands. Enter these commands at the NAT> prompt.

Table 55. NAT Monitoring Commands

Command	Function
? (Help)	Displays all the commands available for this command level or lists the options for specific commands (if available). See “Getting Help” on page xxxii.
List	Lists information about NAT.
Reset	Causes the router to read in the NAT configuration and run according to the NAT access rules that have been configured. NAT does not affect the running of the router until you enter the <b>reset NAT</b> command.
Exit	Returns you to the previous command level. See “Exiting a Lower Level Environment” on page xxxii.

### List

Use the **list** command to display information about the NAT configuration.

#### Syntax:

```
list
    all
    binding
    fragment
    global
    reserve
        pools
        addresses
    statistics
    translate
```

In the following example, times are displayed as hours, minutes, and seconds. Entry age is the time elapsed since the entry was last used. A binding means that a session is established between these two addresses. The timeouts determine how much time will elapse after the last communication before a binding is dropped. See the **set** command in Talk 6 for more information about timeouts.

#### Example:

```
NAT>list all
NAT Globals:
Current State      Tcp Timeout      Non-Tcp Timeout      Memory Usage (in bytes)
ENABLED           24:00:00         0:01:00              408

NAT Statistics:
Requests :      Passes      Drops      Holds
0 :          0          0          0

NAT Address Binding(s):
Private Address//Port  Public Address//Port  Bind Type  Entry Age
7.1.1.1 21            9.1.1.1 21          STATIC    0:00:13
10.1.2.3 0              9.1.1.2 0          STATIC    0:00:13

NAT TCP Session Information:
Private Address//Port  Public Address//Port  Tcp State  Data Delta  Entry Age
7.1.1.1 21            9.1.1.1 21          ESTAB'ED   0          0:00:56
```

## Monitoring Network Address Translator

```
NAT Translate Range(s):
Base Ip Address      Range Mask      Associated Reserve Pool
   7.1.1.0           255.255.255.0  carol
  10.0.0.0           255.0.0.0      carol

NAT Reserve Pool(s):
Reserve Pool      Pool Size      NAPT Address      1st Available Address
carol              21             9.1.1.1           9.1.1.12
-----
Number of Reserve Pools using NAPT.....: 1
Number of configured Reserved Addresses: 21

NAT Fragment Information:
Number of Entries      Number of Saved Fragments
          0              0
```

## Reset

Use the **reset** command to reset NAT. This command deletes all bindings, frees all memory used by NAT, and restarts NAT based on the current Talk 6 configuration. Resetting NAT does not disrupt any other components of the 2212.

### Syntax:

**reset nat**

---

## NAT Dynamic Reconfiguration Support

This section describes dynamic reconfiguration (DR) as it affects Talk 6 and Talk 5 commands.

### CONFIG (Talk 6) Delete Interface

NAT does not support the CONFIG (Talk 6) **delete interface** command.

### GWCON (Talk 5) Activate Interface

The GWCON (Talk 5) **activate interface** command is not applicable for NAT. NAT has no SRAM records associated with an interface.

### GWCON (Talk 5) Reset Interface

The GWCON (Talk 5) **reset interface** command is not applicable for NAT. NAT has no SRAM records associated with an interface.

## GWCON (Talk 5) Component Reset Commands

NAT supports the following NAT-specific GWCON (Talk 5) **reset** commands:

### GWCON, Feature NAT, Reset NAT Command

#### Description:

**Reset** stops all NAT timers, sets NAT state to disabled, and frees all memory used by NAT. All translation mappings, packet fragments, and TCP session information is cleared. NAT's initialization routine will read NAT's state from configuration records. If NAT is enabled, pools of public addresses, ranges of private addresses, mapping tables, fragment reassembly tables, timeouts, and timers are all initialized from configuration records. At this point, NAT is again prepared for packets presented to it by IP packet filters.

#### Network Effect:

If NAT is was previously enabled, all TCP sessions will time out and the application will be notified. UDP and datagram mappings will be lost and

## Monitoring Network Address Translator

packets on those datastreams will be dropped. Once NAT is re-initialized, TCP sessions can be re-established, as can UDP and other datagram packet streams.

**Limitation:**

IP Packet Filters must be properly configured in order for IP to pass packets to NAT.

All NAT commands are supported by the **GWCON, feature nat, reset nat** command.

## CONFIG (Talk 6) Immediate Change Commands

NAT supports the following CONFIG commands that immediately change the operational state of the device. These changes are saved and are preserved if the device is reloaded, restarted, or you execute a dynamically reconfigurable command.

Commands
CONFIG, feature nat, reset nat

## Chapter 30. Using a Dial-In Access to LANs (DIALs) Server

A DIALs Server allows remote users to dial in to a LAN and access the resources of the LAN in the same manner as if they were locally attached with a LAN adapter. Similarly, the DIALs Server also allows LAN-attached users to dial out to WAN resources (such as bulletin boards, FAX machines, Internet Service Providers (ISP) and other on-line services) eliminating the need for an analog phone line and modem on their workstation.

The DIALs Server can be configured for both dial-in and dial-out users simultaneously. The IBM DIALs Dial-In Client runs on the remote workstation and provides the dial-in function. Figure 46 shows an example of a device used as a DIALs Server supporting the dial-in function.

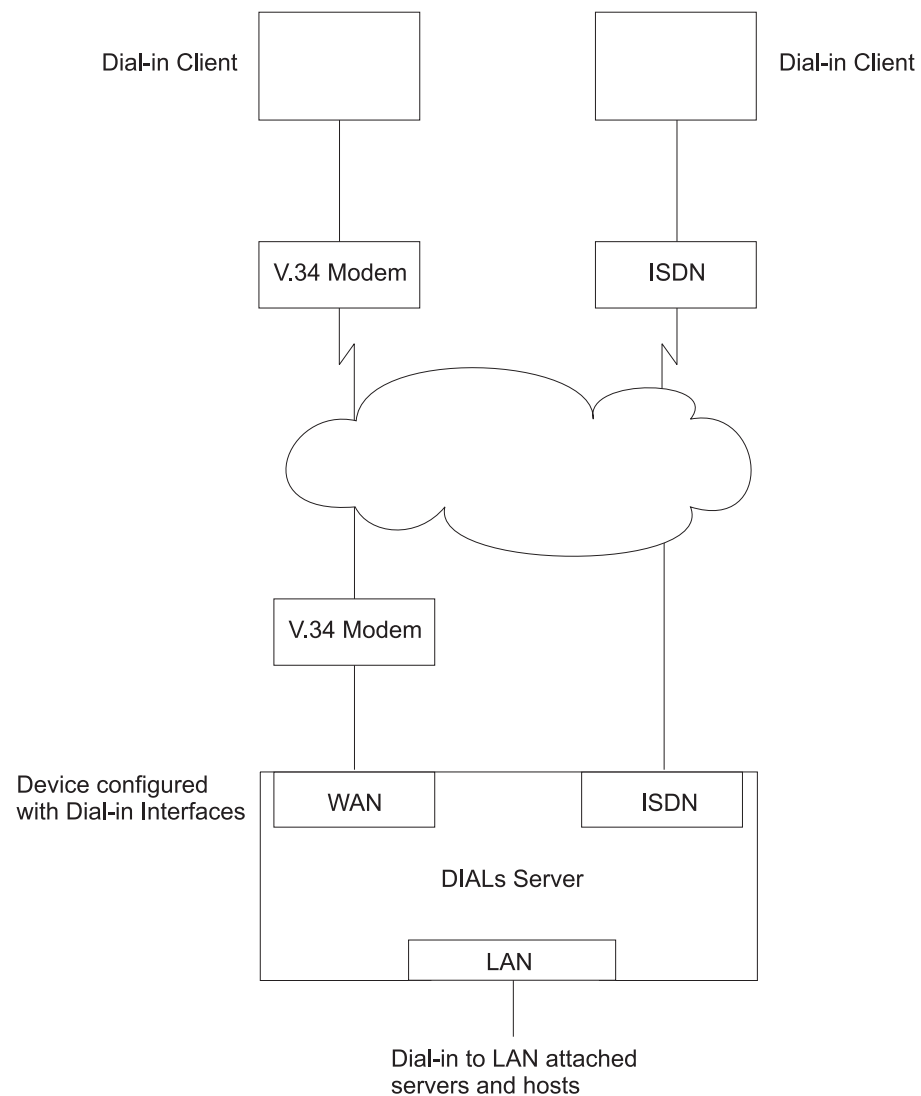

Figure 46. An Example of a DIALs Server Supporting Dial-In

## Using DIALs

The IBM DIALs Dial-Out Client runs on the network-attached workstation and provides the dial-out function. Figure 47 shows an example of a 2212 used as a DIALs Server supporting the dial-out function.

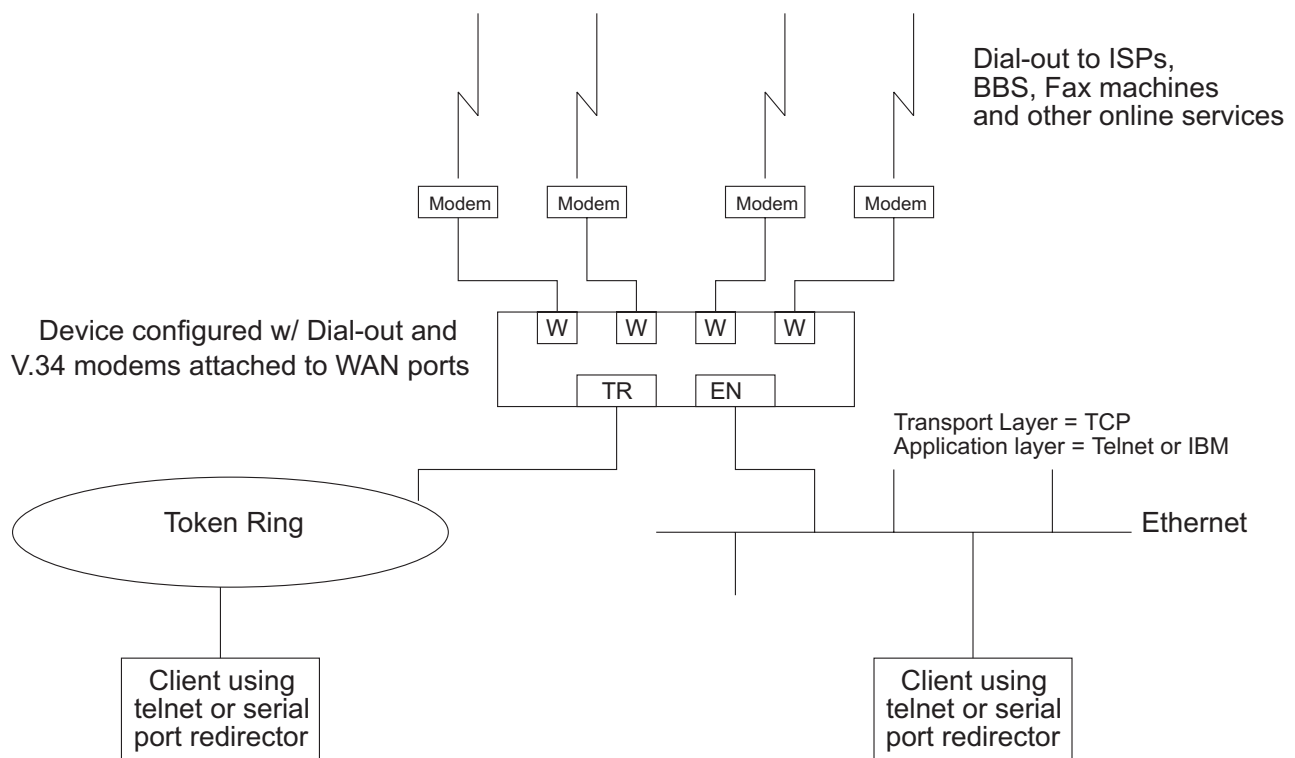

Figure 47. An Example of a DIALs Server Supporting Dial-Out

---

## Before Using Dial-In-Access

Before using Dial-In Access, you need:

- A workstation running the IBM DIALs Dial-In Client or another PPP dial-in client (referred to as the **dial-in client** or **PPP dial-in client** throughout the following sections).
- Completed protocol configurations on the client machine.
- ISDN and ISDN/Digital Modem interfaces, integrated modem interfaces, a null modem interface, or external V.34 modems connected to the WAN ports of the 2212 that you want to use for single user dial-in.
- A fully configured DIALs Server in your LAN.

---

## Configuring Dial-In Access

This section describes how to configure both dial-in and dial-out functions on the DIALs Server. Configuring a client to use dial-in access is described in the documentation associated with the client the workstation uses.

## Configuring Dial-In Interfaces

Dial-in interfaces on the 2212 are a special type of dial-circuit. Because most of the settings for a typical dial-circuit are not relevant for single-user dial-in applications, a new device type called **dial-in** can be added that sets appropriate defaults for the dial-circuit. Adding a dial-in device also sets up the PPP encapsulator configuration



defaults that work with the majority of PPP dial-in clients, including the IBM DIALs Dial-In client. These defaults are described in “Dial Circuit Parameter Defaults for Dial-In Interfaces” and “Dial Circuit PPP Encapsulator Parameters for Dial-In Circuits”.

**Note:** DIALs function can only be enabled on dial-in circuits. Dial-in-Circuits are supported on V.34, ISDN and ISDN/Digital Modem base nets.

### Dial Circuit Parameter Defaults for Dial-In Interfaces

#### Notes:

1. Do not override the parameters described in this section. Doing so will prevent the dial-in function from operating correctly.
2. Some parameters may not be displayed or configurable. For a complete description of the parameters, see “Configuring and Monitoring Dial Circuits” in the *Access Integration Services Software User's Guide*.

The following defaults are set when you add a dial-in interface:

- **Idle time** is set to 0. Note that a standard circuit is defined as a circuit where the idle timer has no meaning. It will not be a fixed circuit to automatically dial-out. The only time the circuit will dial-out is if a PPP callback has been negotiated or if Multilink PPP has been enabled on this circuit. See “Shiva Password Authentication Protocol (SPAP)” and “Using the Multilink PPP Protocol” in the *Access Integration Services Software User's Guide*.
- **Inbound calls** are allowed. Any inbound is setup because PPP dial-in clients do not use the LID exchange implemented by Nways dial-circuits.
- **Outbound calls** are allowed.

**Note:** “Outbound” for a dial-in circuit is not the same as a dial-out circuit. See “Before Configuring Dial-Out Interfaces” on page 464.

- A default destination address is set up for “default\_address” This address is added to the list of V.34 addresses. Because these calls are inbound and the only outbound calls will be the result of either a callback or a multilink PPP exchange, the destination address is meaningless. However the address is required for the circuit parameters. Do not delete this address or your circuits will come up disabled.

### Dial Circuit PPP Encapsulator Parameters for Dial-In Circuits

**Note:** For a complete description of the following parameters see “Using Point-to-Point Protocol Interfaces” in *Access Integration Services Software User's Guide*.

The following defaults are set when you add a dial-in interface:

- Authentication is enabled for SPAP, CHAP, and PAP.
- The PPP MRU is set to 1522. This MRU size is needed for the Windows 3.1, OS/2, and DOS versions of the IBM DIALs Dial-In clients. Do not change this setting unless you know you are not using these clients.
- Automatically enables DIALs on the PPP encapsulator. This turns on some of the features important for Dial-In Access to LANs users such as the NetBIOS Control protocol, NetBIOS Frame Control protocol, time remaining, SPAP authentication, callback, LCP identification, and automatic addition and deletion of IP static routes to the client. See “Using Point-to-Point Protocol Interfaces” in *Access Integration Services Software User's Guide* for more information on the DIALs features.

## Using DIALs

### Adding a Dial-In Interface

To add a dial-in interface:

1. Configure a V.34, ISDN or ISDN/Digital Modem interface on the 2212. See "Using the V.34 Network Interface" in the *Access Integration Services Software User's Guide* for configuration details. See "Using the ISDN Interface" in the *Access Integration Services Software User's Guide* for ISDN and Digital Modem interfaces.
2. Enter **talk 6** to access the Config > prompt.
3. Enter **add device dial-in** at the Config > prompt to add the dial-in interface. You will be asked how many dial-in circuits to add. This command will create the new nets, report their net numbers, prompt for the base net number and prompt to enable for Multilink PPP.

**Example:** Assume the current maximum net is 3 and you want to add 1 dial-in net to the base 2 net.

Figure 48 is an example of defining a dial-in interface.

Figure 48. Adding a Dial-In Interface

```
Config>add dev dial-in
Adding device as interface 4
Defaulting Data-link protocol to PPP
Use "net 4" command to configure circuit parameters
Base net for this circuit [0]? 2

Enable as a Multilink PPP link? [no]

Disabled as a Multilink PPP link.

Use "set data-link" command to change the data-link protocol
Use "net " command to configure dial circuit parameters.
Config>li dev
Ifc 0      Ethernet                CSR 81600, CSR2 80C00, vector 94
Ifc 1      V.34 Base Net          CSR 81620, CSR2 80D00, vector 93
Ifc 2      V.34 Base Net          CSR 81640, CSR2 80E00, vector 92
Ifc 3      PPP Dial-in Circuit
Ifc 4      PPP Dial-in Circuit
```

## Before Configuring Dial-Out Interfaces

Before configuring and using dial-out interfaces on the 2212, you need:

- IBM software with DIALs support loaded on a 2212.
- An external V.34 modem, an integrated modem, or a null modem, if connecting to an available WAN port on the 2212. See "Using the V.34 Network Interface" in the *Access Integration Services Software User's Guide* for configuration information.
- A workstation connected to the LAN that has access to the 2212 DIALs Server.
- Software on the client such as Telnet, a Telnet redirector or the IBM DIALs Dial-Out clients. IP must be correctly configured on the client in order for the dial-out client to work.

## Null Modem Usage

When using a null modem, use D25NM-3 full handshake:

Pin mapping:

```
1 to 1      1 to 1
2 to 3      3 to 2
```

4 to 5	5 to 4
6 to 8, 20	8, 20 to 6
7 to 7	7 to 7

## Configuring Dial-Out Interfaces

The following steps describe how to configure a dial-out interface on your device.

1. Connect a V.34 modem to the WAN port that you will use as a dial-out interface.
2. Connect to the console of the 2212 DIALs Server.
3. Enter **talk 6** at the \* prompt.
4. Set up a V.34 interface. See “Using the V.34 Network Interface” in the *Access Integration Services Software User’s Guide* for details.
5. Add a dial-out interface using the **add device dial-out** command. When prompted for the interface, use an available V.34 interface number.

### Notes:

- a. Multiple circuits can be configured on top of a V.34 base net. However, only one circuit can be active at any given time.
  - b. The software defines a V.34 address called **default\_address**. Do not delete this address as it is required by dial-out and dial-out will not work without it.
6. Configure the PPP authentication server, if you are using the IBM DIALs Dial-Out client, and add PPP users as described in “PPP Authentication Protocols” in the *Access Integration Services Software User’s Guide*. The added PPP users should have dial-out enabled. Dialing out using Telnet does not require authentication, therefore do not configure authentication for Telnet sessions.
  7. Configure the global dial-out parameters using the **feature dials** command. See the **feature** command in the *Access Integration Services Software User’s Guide*. In this environment you can configure the dial-out inactivity timer, the dial-out server name, modem pools, and other parameters.
  8. For the IBM DIALs Dial-Out client to work correctly, SNMP must be enabled on the 2212 and an SNMP community named *public* must be defined on the 2212 with read access. This is required for the dial-out chooser application to be able to discover dial-out servers on the network. Refer to “SNMP Management” in the *Protocol Configuration and Monitoring Reference Volume 1* for information about how to enable SNMP and how to configure an SNMP community.
  9. Restart the device.

## Configuring Modem Pools

Modem pools are defined as a group of modems which appear to the user as one modem. When the user needs to dial-out, the first available modem in this pool is used. Modem pools are created in the 2212 DIALs Server by defining groups of dial-out interfaces with the same portname. By default, all dial-out interfaces are named “ALL\_PORTS” which creates a modem pool. Naming the dial-out interfaces individually enables a user to select a particular modem to dial-out.

To configure a modem pool:

1. Enter **talk 6** at the \* prompt.
2. Enter **net n**, where *n* is the number of the dial-out interface as defined in “Using the V.34 Network Interface” in the *Access Integration Services Software User’s Guide*. This action places you in the configuration environment for the interface.

## Using DIALs

3. Enter **encapsulator** (see “Configuring and Monitoring Dial Circuits” in the *Access Integration Services Software User’s Guide* ) at the `Circuit Config>` prompt. This action places you in the dial-out configuration environment.
4. Enter **set portname** at the `Dial-out Config>` prompt. This action will prompt you for the name of the port (up to 30 characters). If you specify an existing port name, the modem is added to the pool with that name.
5. Restart the 2212.

---

## Before Configuring Global DIALs Parameters

This section describes the global DIALs Server parameters.

### Server Provided IP Addresses

The router can be configured to provide an IP address for a dial-in client to use for the duration of its connection. The address the router will assign to the client can be retrieved by 4 different methods. These methods, in order of priority are listed below:

1. User ID

An IP address can be stored in the PPP user profile for each client. When a client connects and requests an IP address, the router retrieves the address configured in that user’s PPP user profile. This allows the user to get the same IP address each time, but requires a unique IP address for every user.

Use the `Config> add ppp-user` command to configure an IP address in the PPP user profile.

2. Interface

An IP address can be stored in the dial-in interface configuration. When a client connects and request an IP address, the router retrieves the address from the interface through which the connection was made. This method requires a unique IP address for each dial-in interface.

To set the interface IP address:

- Use the `Config> list devices` command to display the interface number assigned to the hardware interface.
- Use the `Config> net 'x'` command, where 'x' is the configured interface number, to access the command prompt for the interface.
- Use the `PPP Config> set ipcp` command to set the interface IP address.

3. Pool

Blocks of IP addresses can be stored in a IP address pool. When a client connects and requests an address, the router retrieves an address from the pool. When the client disconnects, the address is returned to the pool. This method provides a single location for configuring dial-in client’s IP address without the need for an address server.

Use the `DIALs config> add ip-pool` command to add a pool of IP addresses.

4. DHCP Proxy

An IP address can be leased from a DHCP server. When a client connects and requests an address, the router requests an address from the DHCP server on behalf of the client. This method requires a DHCP server be present on the LAN or configured in the router. One DHCP server can provide addresses for clients on multiple routers. See “Dynamic Host Configuration Protocol (DHCP)” on page 467 for more information.

Use the `DIALs config> add dhcp-server` command to add a DHCP server.

## IP Address Assignment Methods

The IP address used by a dial-in client for the duration of the connection may come from 5 different sources. These sources are listed in order of precedence:

1. client provided
2. user id assigned
3. interface assigned
4. address pool
5. DHCP server

When a dial-in client connects, the router steps through these sources until it finds an address or exhausts all sources. If no IP address can be found, IPCP negotiation fails. Any combination of methods may be used.

The default configuration is:

```
Client      : Enabled
UserID     : Enabled
Interface  : Enabled
Pool       : Enabled
DHCP Proxy : Disabled
```

**Note:** There are no addresses configured by default in the PPP user profile, the interface or the IP address pool.

## Dynamic Host Configuration Protocol (DHCP)

The Dynamic Host Configuration Protocol (DHCP) was developed to provide configuration parameters to hosts on a network. Among other configuration parameters, DHCP has a mechanism for allocation of network addresses to hosts.

The Proxy DHCP feature acts as a client *on behalf* of a dial-in PPP user. This allows the device to obtain an IP address lease for the duration of the dial-in session, or until the lease expires. The IP address that is allocated from the DHCP server is communicated to the dial-in client through PPP IPCP (see “IP Control Protocol” in the *Access Integration Services Software User’s Guide* for a description of IPCP). The dial-in client software has no knowledge that DHCP was used to allocate an IP address, and thus requires no DHCP activation of any kind.

Proxy DHCP requires that at least one DHCP server be configured and accessible from the router.

Proxy DHCP requires that the addresses being allocated to dial-in users be within the same subnet of a directly connected LAN. In a typical configuration, this requires enabling proxy ARP subnet routing to allow the router to answer ARP requests to hosts on the local network on behalf of the dial-in clients.

### Basic DHCP Setup

The most basic configuration calls for a single DHCP server on the same network as the router, with dial-in addresses to be leased within the same subnet as this LAN.

When the client dials in, a lease for an IP address is obtained from the DHCP server and used in IPCP negotiation with the client.

1. Connect 2212 and DHCP to the same LAN.
2. Configure and start the DHCP server (see your DHCP server’s documentation for how to setup your server to lease IP addresses. Remember, the IP

## Using DIALS

addresses to be leased MUST be within a subnet of a directly connected LAN and proxy ARP must be enabled on the 2212).

3. The typical setup for Proxy DHCP disables Client-Specified, Userid, and Interface and Pool IP Address Negotiation options:

```
Dials Config>list ip
DIALS client IP address specification:
Client : disabled
UserID : disabled
Interface : disabled
DHCP Proxy : enabled
```

4. Add DHCP server (Dials Config> **add dhcp 10.0.0.111**)
5. Set dial-in client software to *Server assigned*.

### Notes:

- a. *Server assigned* configuration varies among different dial-in client implementations.
  - b. The client software should not be configured to obtain its address from DHCP. The client should obtain its address by sending an address of 0.0.0.0 to IPCP on the initial configure request.
6. For this setup, let the DHCP GATEWAY ADDRESS default to 0.0.0.0.

## Multiple Hops to DHCP Server

The configured DHCP server(s) should be IP addresses which are reachable from the connected router. You should always be able to ping the server from the remote access box.

When the DHCP server is located multiple hops away, the server needs to know an address to reply to, and to indicate which pool to allocate an IP address from. The pool to allocate an IP from is important because the DHCP server could be utilized to serve addresses to a number of subnets and there must be some indication as to which pool of addresses to select from. The DHCP Gateway Address (*giaddr*) is used for this (the terminology is based on the definition given in RFC 2131). The *giaddr* must be an address that is local to the 2212, such as the token ring or Ethernet LAN port. Also, since the *giaddr* is the address which the DHCP server will use to reply, make sure you can ping this address from the DHCP server itself.

## Multiple DHCP Servers Network

You can configure multiple DHCP servers for redundancy. When you configure multiple servers, the Proxy DHCP client asks all servers for an address and accepts the first response received. If any of the DHCP servers are more than one hop away, or are connected to a subnet which is not associated with the addresses in its pool, then *giaddr* must be configured. See “Multiple Hops to DHCP Server”.

While there can be more than one DHCP server offering addresses, it is important to not allow the pool of addresses configured at each server to overlap. Further, because there is only one *giaddr* for the DHCP server to respond to and perform a lookup with, each pool of address must be in the same subnet as each other.

## Dynamic Domain Name Server (DDNS)

A Domain Name Server (DNS) maps IP addresses to hostnames and is typically static in nature. Dynamic DNS is a feature that, when used with a DDNS DHCP server and a DNS server, enables DHCP to dynamically update the DNS server with an IP address and hostname mapping. This feature may only be used in conjunction with Proxy DHCP.

When you enable Dynamic DNS on the 2212 and you configure a hostname in the user profile (see “PPP Authentication Protocols” in the *Access Integration Services*

*Software User's Guide*), this hostname is passed as option 81 (DDNS) to the DHCP SERVER. If you configured the DHCP server correctly for DDNS, the DHCP server updates the DDNS server with the IP address that it leased to the router and the hostname that the router sent to it. This allows other users to access the dial-in client through the hostname rather than requiring the client to know the dynamically chosen IP address.





---

## Chapter 31. Configuring DIALs

This chapter describes DIALs configuration and operational commands. It includes the following sections:

- “Accessing the DIALs Global Configuration Environment”
- “DIALs Global Configuration Commands”
- “Accessing the DIALs Global Monitoring Environment” on page 479
- “DIALs Global Monitoring Commands” on page 479
- “Monitoring Dial-In Interfaces” on page 483
- “Monitoring dial-out Interfaces” on page 483
- “DIALs Server Dynamic Reconfiguration Support” on page 484
- “Dial-Out Dynamic Reconfiguration Support” on page 487

---

### Accessing the DIALs Global Configuration Environment

Use the following procedure to access the global configuration process.

1. At the OPCON prompt, enter **talk 6**. (For more detail on this command, refer to *The OPCON Process and Commands* in the Access Integration Services Software User’s Guide.) For example:

```
* talk 6
Config>
```

After you enter the **talk 6** command, the CONFIG prompt (Config>) displays on the terminal. If the prompt does not appear when you first enter configuration, press **Return** again.

2. At the CONFIG prompt, enter the **feature dials** command to get to the DIALs Config> prompt and access the DIALs global parameter configuration environment.

---

### DIALs Global Configuration Commands

Table 56. DIALs Global Configuration Commands

Command	Function
? (Help)	Displays all the commands available for this command level or lists the options for specific commands (if available). See “Getting Help” on page xxxii.
Add	Adds a (Dynamic Host Configuration Protocol) DHCP server to the list of DHCP servers or adds an IP address pool.
Delete	Deletes a DHCP server from the list or removes a block of addresses from an IP address pool
Disable	Disables IP address assignment methods, dial-out protocols, multi-chassis MP, SPAP Banner, and Dynamic DNS.
Enable	Enables various methods of IP address assignments, dial-out protocols, multi-chassis MP, SPAP Banner, and Dynamic DNS.
List	Lists the Global DIALs parameters and their values.
Set	Sets time-allowed, dhcp gateway address, NetBIOS Name Server addresses, locally assigned MAC addresses, Virtual Connections (VC) Dynamic Name Server addresses, dial-out inactivity timer, and dial-out server-name.
Exit	Returns you to the previous command level. See “Exiting a Lower Level Environment” on page xxxii.

## Configuring DIALs

### Add

Use the **add** command to add a new Proxy DHCP server to a list of servers or to add an IP pool of addresses.

The proxy DHCP server list contains the IP addresses of the DHCP servers that will, in turn, lease IP addresses to the dial-in clients. Multiple servers may be added for redundancy. The maximum number of servers is 20.

The IP address pool feature provides a method by which the router may retrieve an IP address from a locally defined pool of addresses to a dial-in client. The client may use this address for the duration of the connection to the router. A pool consists of one or more blocks of IP addresses. The maximum number of blocks is 20. Each of these blocks is defined by a base IP address and the number of addresses in the block. The addresses in each block are ascending and contiguous, starting with the base address.

#### Syntax:

```
add                               dhcp-server ipaddress  
                                     ip-pool baseaddress #addresses
```

#### **dhcp-server ipaddress**

Adds a dhcp-server with the specified IP address.

#### Example :

```
DIALs Config> add dhcp-server  
DIALs Proxy DHCP server address [0.0.0.0]? 10.0.0.1
```

#### **ip-pool baseaddress #addresses**

Add a block of addresses to the IP pool.

#### Example:

```
DIALs Config> add ip-pool  
Base address []? 192.1.100.18  
Number of addresses [1]? 57  
DIALs config>add ip-pool  
Base address []? 192.2.200.1  
Number of addresses [1]? 250  
DIALs config>list ip-pools  
Configured IP address pools:  
Base Address      Last Address      Number  
-----  
192.1.100.18     192.1.100.74     57  
192.2.200.1      192.2.200.250    250
```

### Delete

Use the **delete** command to delete an existing Proxy DHCP server from the list of servers or to remove a block of addresses from the IP address pool.

#### Syntax:

```
delete                             dhcp-server ip address  
                                     ip-pool baseaddress #addresses
```

#### **dhcp-server ipaddress**

Removes a dhcp-server with the specified IP address.

#### Example:

```
DIALs Config> delete dhcp-server  
Enter the address to be deleted [0.0.0.0]? 10.0.0.1
```

**ip-pool** *baseaddress #addresses*

Removes a block of addresses from the IP pool.

**Example:**

```
DIALs Config> delete ip-pool
Base IP address of the block to be removed []? 192.2.200.1
```

## Disable

Use the **disable** command to disable an IP address assignment method, dial-out protocols, SPAP Banner, and Dynamic DNS.

**Syntax:**

```
disable                dynamic-dns
                        dial-out
                        ip-address-assignment type
                        spap-banner
```

**dial-out** *type*

Disables the use of dial-out with either Telnet or IBM DIALs dial-out clients. You can specify:

**dials** Disables all IBM DIALs dial-out clients

**telnet** Disables all Telnet clients.

To disable both types of clients you must enter the `disable dial-out` command for each type. Disabling both types of clients disables dial-out on the 2212.

**dynamic-dns**

Disables the sending of DHCP option 81 for the user's hostname. See "Dynamic Domain Name Server (DDNS)" on page 468 for more information.

**IP-address-assignment** *type*

Disables various IPCP address assignment techniques. You may specify any of the following:

- Client – Prevents client-assigned IP address assignment.
- Userid – Prevents using the authenticated user profile for an IP address.
- Interface – Prevents the router from using the IPCP settings for the interface.
- Pool – Prevents the router from using the IP address pool to assign addresses to clients.
- DHCP-proxy – Prevents the router from leasing an address from the DHCP server.

See "Server Provided IP Addresses" on page 466 for additional information about assignment techniques.

**spap-banner**

Disables the sending of a SPAP banner to a remote user authenticated with SPAP.

**Note:** Entering a `\n` will force a new line character in the banner displayed at the client.

## Configuring DIALs

### Enable

Use the **enable** command to enable IP address assignment, dial-out protocols, SPAP Banner, and Dynamic DNS.

#### Syntax:

```
enable                dynamic-dns  
                        ip-address-assignment . . .  
                        spap-banner
```

#### **dial-out type**

Enables the use of dial-out with either Telnet or IBM DIALs dial-out clients. By default, both types of clients are enabled. You can specify:

**dials** Enables all IBM DIALs dial-out clients

**telnet** Enables all Telnet clients.

#### **dynamic-dns**

Disables sending of DHCP option 81 for the user's hostname. See "Dynamic Domain Name Server (DDNS)" on page 468 for more information.

#### **IP-address-assignment type**

Enables various IPCP address assignment techniques. The router will attempt each method enabled in the order listed. You may specify any of the following:

- Client – Allows the client to specify the address it wants to use.
- Userid – The router will look in the authenticated PPP user profile for an IP address. If the address is nonzero, it will be offered to the client.
- Interface – The router will look at the IP address configured on the interface. If the address is nonzero, it will be offered to the client.
- Pool – The router will request an address from the IP address pool. If an address is available, it will be offered to the client.
- DHCP-proxy – The router will attempt to lease an address from DHCP. If successful, the address will be offered to the client.

See "Server Provided IP Addresses" on page 466 for additional information about assignment techniques.

#### **spap-banner**

Enables the sending of a SPAP banner to a remote user authenticated with SPAP. Use the **set spap-banner** command described on "Set" on page 476 to enter the text of the SPAP banner. Refer to "Shiva Password Authentication Protocol (SPAP)" in the *Access Integration Services Software User's Guide* for more information.

### List

Use the **list** command to display the current configuration. The DHCP state and lease times can be monitored for each net from the Point-to-Point console. See the **listipcp** command in the *Access Integration Services Software User's Guide* for an example.

#### Syntax:

```
list                  all  
                        dhcp-servers
```

dial out  
dynamic-dns  
ip-address-assignment  
ip-pools  
name-servers  
spap-banner  
time-allowed  
vc-parameters

### Example:

```

DIALS config>li all
DIALS client IP address assignment:
Client      : Enabled
UserID     : Enabled
Interface  : Enabled
Pool       : Enabled
DHCP Proxy : Disabled

Configured IP address pools:
  Base Address      Last Address      Number
  -----
  11.0.0.100       11.0.0.129       30
  11.0.0.210       11.0.0.229       20

Configured DHCP servers:          11.0.0.2          11.0.0.50
Proxy DHCP is currently disabled
DHCP gateway address (giaddr): 11.0.0.10

Dynamic DNS: Enabled

Primary Domain Name Server (DNS): 11.0.0.2
Secondary Domain Name Server (DNS): None
Primary NetBIOS Name Server (NBNS): 11.0.0.2
Secondary NetBIOS Name Server (NBNS): None

Time allowed for connections: Unlimited

SPAP banner :Enabled
Welcome to the network...

Box-level dial-out settings
Inactive timer:                               15
LAN Protocols enabled for dial-out:          TELNET DIALs
Server name:                                 DIALOUT_SERVER

Number of Mac Addresses defined = 0
Base MAC Address: 000000000000

VC: Maximum Virtual Connections = 50
VC: Maximum suspend time (hours) (0 is unlimited) = 12
VC: Idle timeout period (seconds) = 30

Multi-chassis MP: Endpoint discriminator (0 means use box s/n) = 0

DIALS config>
  
```

The example shows the following:

### DIALS client IP address specification

Displays the IP address assignment techniques and whether they are enabled. You would receive this section of the display and the section containing the box-level dial-out settings in response to the **list ip-address-assignment** command.

## Configuring DIALs

### IP address pools

Displays the configured IP address pools. You would receive this section of the display in response to the **list ip-pool** command.

### Configured DHCP servers

Displays the list of IP addresses currently configured as DHCP servers. This section also lists the interface being used for the DHCP gateway. You would receive this section of the display in response to the **list dhcp-servers** command.

### Dynamic Name Servers

Displays whether Dynamic DNS is enabled. You would receive this section of the display in response to the **list dynamic-dns** command.

### primary domain server (dns)

This line and the following lines display the configured primary and secondary name servers. You would receive this section of the display in response to the **list name-servers** command.

### time allowed

Displays the maximum amount of time (in minutes) for dial users. You would receive this section of the display in response to the **list time-allowed** command.

### spap banner

Displays the contents of the spap banner. You would receive this section of the display in response to the **list spap-banner** command.

### vc connections

Displays information about configured virtual connections.

### multi-chassis mp

Displays the configured endpoint discriminator.

## Set

Use the **set** command to set the time-allowed, dhcp gateway address, NetBIOS Name Server addresses, Dynamic Name Server addresses and dial-out inactivity timer , and dial-out server-name.

### Syntax:

```
set                dhcp-gateway-address  
                   dial-out . . .  
                   dns . . .  
                   laa  
                   multi-chassis-mp  
                   nbns . . .  
                   spap-banner . . .  
                   time-allowed  
                   vc-parameters
```

### **dhcp-gateway-address interface# ipaddress**

Sets the IP address associated with the DHCP gateway. DHCP uses the address as:

1. An address to which DHCP replies

2. An indication of the pool of addresses from which DHCP allocates an IP address

If the DHCP server is not on a directly attached LAN interface, then you must configure this address to the address of one of the LAN interfaces that has IP connectivity to the DHCP server. See “Dynamic Host Configuration Protocol (DHCP)” on page 467 and the definition of “giaddr” in RFC 1541 for more information.

### **dial-out parameter**

Sets the inactivity timer or server name for dial-out nets. **Parameter** can be:

#### **inactivity-timer**

Sets the dial-out inactivity timer for dial-out nets. This is defined as the amount of time, in minutes, that a user can be connected without data traffic over the connection. For example, if the inactivity-timer is set to 5 minutes and during any 5-minute interval, no data is received or transmitted, the connection will be dropped and the modem will become available. The default is 0, which means that the inactivity timer is disabled and the connection will be maintained indefinitely.

#### **servername**

Sets the name of the dial-out server. This can be any string up to 30 characters in length. The default is “2210\_DIALS\_SERVER”. This is the name that the IBM DIALS dial-out clients see when they use the “Chooser” application to discover dial-out servers. This parameter has no meaning for Telnet dial-out clients.

### **dns type ipaddress**

Configures the primary and secondary domain name servers (DNS). **Type** can be:

#### **primary**

Sets the IP address of the primary DNS server for the dial-in client to use. This value is negotiated during IPCP for some dial-up clients (particularly Windows® 95).

#### **secondary**

Sets the IP address of the secondary DNS server for the dial-in client to use. This value is negotiated during IPCP for some dial-up clients (particularly Windows 95).

### **laa #MAC\_addresses MAC\_address\_base**

Sets the number of MAC addresses and the base address for the Locally Administered Address (LAA) table. Only Layer-2-Tunneling nets will use LAA addresses.

#### **#MAC\_addresses**

Specifies the number of Mac addresses to add to the LAA table, beginning with the *MAC\_Address\_Base*.

**Valid values:** 0 to 256

**Default value:** 0

#### **MAC\_address\_base**

Specifies the base MAC address of the LAA table.

**Valid values:** Any valid MAC address

**Default value:** 000000000000

## Configuring DIALs

### Example:

```
DIALs config>set 1aa
Number of Mac Addresses: [0]? 20
Locally Administered Mac Address Base (hex) [000000000000]? 002210aaaaaa
DIALs Config>
```

### multi-chassis-mp

Sets the endpoint discriminator to be used. All links that are to join the same bundle must have the same endpoint discriminator.

### Example:

```
DIALs Config> set multi-chassis-mp
Enter Endpoint Discriminator to use from stacked group (0 for box S/N): 2345
```

### nbns type ipaddress

Configures the primary and secondary NetBIOS name servers. *Type* can be:

#### primary

Sets the IP address of the primary NetBIOS name server.

#### secondary

Sets the IP address of the secondary NetBIOS name server.

### spap-banner

Allows configuration of a message that is sent out to all clients that successfully complete SPAP authentication.

### Example:

```
DIALs config>set spap-banner
SPAP banner :Disabled

Enter Banner: Welcome to the network...
```

### time-allowed

Sets the time allowed for PPP dial-in users and dial-out users. This parameter defines the maximum amount of time (in minutes) that a user can be connected. The default value is 0, which means the user can be connected for an unlimited amount of time.

### vc-parameters

Use this parameter to set the global default virtual connection attributes. The system prompts you for the maximum number of connections, the maximum suspend time, and the inactivity timeout value.

### Example:

```
Config> feature DIALs
DIALs Config> set vc-parameters
Maximum Virtual Connections [50]? 40
Maximum suspended time (hours) (0 is unlimited) [10]? 18
Inactivity Timeout (seconds) [30]? 60
DIALs Config>
```

#### Maximum Virtual Connections

The maximum number of virtual connections that can be active or suspended. When using VCs with MP, configure this value to be 1 greater than the number of physical connections.

**Valid values:** 0 to 255

**Default value:** 50

#### Maximum suspended time

The maximum amount of time, in hours, a virtual connection can be



suspended before the system ends the connection. Specifying 0 for this parameter allows a virtual connection to be suspended indefinitely.

**Valid values:** 0 to 48

**Default value:** 12

### Inactivity Timeout

The number of seconds that a virtual connection can be inactive before it is suspended.

**Valid values:** 10 to 1024

**Default value:** 30

---

## Accessing the DIALs Global Monitoring Environment

Use the following procedure to access the DIALs monitoring commands.

1. At the OPCON prompt, enter **talk 5**. (For details on this command, see the chapter “The OPCON Process and Commands” in *Access Integration Services Software User’s Guide*.) For example:

```
* talk 5
+
```

After you enter the **talk 5** command, the GWCON prompt (+) displays on the terminal. If the prompt does not appear when you first enter configuration, press **Return** again.

2. At the + prompt, enter the **feature dials** command to get you to the DIALS Console> prompt and access the global monitoring environment.

### Example:

```
+ feature dials
DIALS Console>
```

---

## DIALs Global Monitoring Commands

Table 57. DIALs Global Monitoring Commands

Command	Function
Clear	Clears a specific suspended virtual connection.
List	Displays the state of various virtual connections, or all virtual connections.
Reset	Dynamically activates DIALS parameters.
Exit	Returns you to the previous command level. See “Exiting a Lower Level Environment” on page xxxii.

### Clear

Use the **clear** command to clear specific suspended virtual connections.

#### Syntax:

```
clear vc connection_id
```

*vc connection\_id*

Specifies the suspended virtual connection that you are ending. To obtain the *connection\_id*, enter either the **list all-vc** or **list suspended-vc** command.

## Configuring DIALs

### List

Use the **list** command to display all virtual connections, active virtual connections, suspended virtual connections, or the values of the vc-parameters.

#### Syntax:

```
list                all
                    active-vcs
                    all-vcs
                    dhcp-servers
                    ip-address-assignment
                    ip-pool
                    suspended-vcs
```

#### active-vc

Displays the attributes of all active virtual connections. See description of the **all-vc**s parameter for an explanation of the attributes.

#### all-vc

Displays the attributes of all active and suspended virtual connections. This display is a combination of the displays for the **list active-vc**s and **list suspended-vc**s commands.

#### Example:

```
+ feature dials
DIALS console> list all
DIALS client IP address assignment:
Client      : Enabled
UserID     : Enabled
Interface  : Enabled
Pool       : Enabled
DHCP Proxy : Disabled
```

```
Current IP address pools:
  Base Address      Last Address      Total      Free
  -----
*  11.0.0.100      11.0.0.129      30         30
   11.0.0.210      11.0.0.229      20         19
```

```
Current DHCP servers:      11.0.0.2      11.0.0.50
Proxy DHCP is currently disabled
DHCP gateway address (giaddr): 11.0.0.10
```

```
Active VCs:
Conn ID  Interface  Idle-Timeout  Connected  Username
=====  =====  =====  =====  =====
1656494850  8          30          0:26:15  don
7293521502  9          30          1:41:57  jane
```

```
Suspended VCs:
Conn ID  Hrs.Max  Suspend  Suspended  Username
=====  =====  =====  =====  =====
9256166098  12       0: 4:13  joe
```

The attributes for active and suspended VCs are:

#### Conn ID

The connection id of the virtual connection. The system assigns the id when it establishes the connection.

### Username

The AAA, RADIUS, or local-list user that establishes the virtual connection.

For active VCs:

### Interface

The network interface that is managing the virtual connection.

**Note:** Do not assign IP addresses to dial-up clients using interface assignment to avoid problems caused by other users using this interface which the VC suspended.

### Idle Timeout

The amount of inactive time, in seconds, after which the system will suspend the VC. This corresponds to the value of inactivity timer in the **set** command.

### Connected HHH:MM:SS

The total amount of time in hours, minutes, and seconds, that the VC has been connected to an interface.

For suspended VCs:

### Hrs. Max Suspended

The maximum number of hours a VC can be in suspend state before the system ends the connection. This corresponds to the value of maximum suspended time in the **set** command.

### Suspended HH:MM:SS

The total amount of time in hours, minutes, and seconds, that the VC has been suspended.

### dhcp-servers

Displays configured information about DHCP servers and their IP addresses.

### ip-address-assignment

Display the methods by which IP addresses can be assigned to clients

### ip-pool

Display the current usage of the pool.

#### Example:

```
DIALs Console> list ip-pool
```

```
Current IP address pools:
```

	Base Address	Last Address	Total	Free
*	192.1.100.18	192.1.100.74	57	57
	192.2.200.1	192.2.200.250	250	250

Note: The \* indicates from which block the next address will be retrieved.

### suspended-vcs

Displays the attributes of all suspended virtual connections. See description of the **all-vcs** parameter for an explanation of the attributes.

### vc-parameters

Displays the values of the vc-parameters that were set using the **set vc-parameters** command.

## Reset

Use the **reset** command to dynamically activate the configuration changes made to the DIALs interface in talk 6.

## Configuring DIALs

### Syntax:

**reset** all  
    dhcp-parameters  
    ip-address-assignment  
    ip-pool  
    vc-parameters

**all** Dynamically activate the DHCP, IP address assignment, and IP-pool configuration changes.

### dhcp-parameters

Dynamically activate the DHCP configuration.

### ip-address-assignment

Dynamically activate the IP address assignment method configuration.

### ip-pool

Dynamically activate the IP address pool configuration.

### vc-parameters

Dynamically updates VC config changes.

---

## dial-out Interface Configuration Commands

To access the dial-out interface parameter environment:

1. Enter **talk 6** at the \* prompt.
2. Enter **net n** at the Config > prompt.
3. Enter **encapsulator** at the Circuit config: n> prompt.

Table 58 lists the commands available from the dial-out config> prompt.

Table 58. dial-out Interface Configuration Commands

Command	Function
? (Help)	Displays all the commands available for this command level or lists the options for specific commands (if available). See "Getting Help" on page xxxii.
Set	Defines the port name associated with a modem.
Exit	Returns you to the previous command level. See "Exiting a Lower Level Environment" on page xxxii.

## Set

Use the **set** command to define the port name for a modem.

### Syntax:

**set** portname *name*

### portname

Defines the name of the port associated with a modem. Use this name to define **modem pools**. The name can be up to 30 characters in length.

**Default value:** ALL\_PORTS

**Example:** dial-out config>**set portname localcalls**

## Monitoring Dial-In Interfaces

Monitoring dial-in interfaces is the same as monitoring other PPP dial circuits. For details, see “Configuring and Monitoring Point-to-Point Protocol Interfaces” in the *Access Integration Services Software User’s Guide*.

## Monitoring dial-out Interfaces

Table 59 lists the commands available when monitoring dial-out interfaces.

Table 59. dial-out Interface Monitoring Commands

Command	Function
? (Help)	Displays all the commands available for this command level or lists the options for specific commands (if available). See “Getting Help” on page xxxii.
Clear	Resets the statistics for this dial-out interface.
List	Lists the current state of the dial-out interface, the number of bytes transmitted and received on this interface, and the client’s current parameters.
Exit	Returns you to the previous command level. See “Exiting a Lower Level Environment” on page xxxii.

### Clear

Use the **clear** command to reset the statistics for the number of octets received and transmitted by this interface.

**Syntax:**

**clear**

**Example:**

```
clear
Statistics reset.
```

### List

Use the **list** command to display current state of the dial-out interface. The **list** command always displays the current state of the dial-out net, the time since the state change, and the number of bytes received and transmitted.

**Syntax:**

**list**

**Example for inactive interface:**

```
list
Dial-out Settings for current session:

Dial-out state is DOWN
Time since change           = 52 minutes and 34 seconds

Dial-out Octets transmitted = 0
Dial-out Octets received   = 0

Session down, no valid settings
```

**Note:** When a client connects to a dial-out port using Telnet, no user name is present because the server did not perform any authentication.

**Example for active interface:**

## Configuring DIALs

```
list
Dial-out Settings for current session:

Dial-out state is UP
Time since change          = 3 seconds

Dial-out Octets transmitted = 14
Dial-out Octets received   = 765

Current user                = not available
Time allowed for user       = unlimited
Inactivity timer for port   = 10 minutes
Line speed                  = 57600
Current DTR state           = DTR ON
Current dial-out protocol   = TELNET
Options negotiated:
    Will Suppress Go Ahead
    Wont' Echo characters
```

### Example for an active IBM DIALs dial-out client:

```
list
Dial-out Settings for current session:

Dial-out state is UP
Time since change          = 12 seconds

Dial-out Octets transmitted = 11
Dial-out Octets received   = 756

Current user                = ebooth
Time allowed for user       = unlimited
Inactivity timer for port   = 10 minutes
Line speed                  = 57600
Current DTR state           = DTR ON
Current dial-out protocol   = DIALs
```

---

## DIALs Server Dynamic Reconfiguration Support

This section describes dynamic reconfiguration (DR) as it affects Talk 6 and Talk 5 commands.

### CONFIG (Talk 6) Delete Interface

Dial-In Access to LANs (DIALs) Server does not support the CONFIG (Talk 6) **delete interface** command.

### GWCON (Talk 5) Activate Interface

Dial-In Access to LANs (DIALs) Server supports the GWCON (Talk 5) **activate interface** command with no restrictions.

The following table summarizes the Dial-In Access to LANs (DIALs) Server configuration changes that are activated when the GWCON (Talk 5) **activate interface** command is invoked:

Commands whose changes are activated by the GWCON (Talk 5) activate interface command
CONFIG, feature dials, disable spap-banner
CONFIG, feature dials, enable spap-banner
CONFIG, feature dials, set dial-out inactivity-timer
CONFIG, feature dials, set spap-banner

### GWCON (Talk 5) Reset Interface

DIALs Server supports the GWCON (Talk 5) **reset interface** command with no restrictions.

The following table summarizes the DIALs Server configuration changes that are activated when the GWCON (Talk 5) **reset interface** command is invoked:

Commands whose changes are activated by the GWCON (Talk 5) reset interface command
CONFIG, feature dials, disable spap-banner
CONFIG, feature dials, enable spap-banner
CONFIG, feature dials, set dial-out inactivity-timer
CONFIG, feature dials, set spap-banner

### GWCON (Talk 5) Component Reset Commands

DIALs Server supports the following DIALs Server-specific GWCON (Talk 5) **reset** commands:

#### GWCON, Feature Dials, Reset DHCP-Parameters Command

**Description:**

This command resets the DIALs parameters that are associated with the proxy DHCP function.

**Network Effect:**

None.

**Limitations:**

None.

The following table summarizes the DIALs Server configuration changes that are activated when the **GWCON, feature dials, reset dhcp-parameters** command is invoked:

Commands whose changes are activated by the GWCON, feature dials, reset dhcp-parameters command
CONFIG, feature dials, add dhcp-server
CONFIG, feature dials, delete dhcp-server
CONFIG, feature dials, set dhcp-gateway-address

#### GWCON, Feature Dials, Reset IP-Address-Assignment Command

**Description:**

This command is used to activate changes to the IP address assignment methods. This will not change currently assigned addresses, but specifies how IP addresses may be assigned on future connections. Dynamic DNS configuration change is also activated with this command.

**Network Effect:**

None.

**Limitations:**

None.

The following table summarizes the DIALs Server configuration changes that are activated when the **GWCON, feature dials, reset ip-address-assignment** command is invoked:

Commands whose changes are activated by the GWCON, feature dials, reset ip-address-assignment command
CONFIG, feature dials, enable dynamic-dns

## Configuring DIALs

CONFIG, feature dials, enable ip-address-assignment
CONFIG, feature dials, disable dynamic-dns
CONFIG, feature dials, disable ip-address-assignment

### GWCON, Feature Dials, Reset IP-Pools Command

**Description:**

This command resets the IP address pool definition (addresses added or removed) without disrupting network connections. If a new IP address pool definition does not include addresses that were previously in the pool and are currently in use, the addresses will remain in use after the reset. When these addresses are freed by the interface, they will not return to the IP address pool and will not be assigned again.

**Network Effect:**

None.

**Limitations:**

None.

The following table summarizes the DIALs Server configuration changes that are activated when the **GWCON, feature dials, reset ip-pools** command is invoked:

<b>Commands whose changes are activated by the GWCON, feature dials, reset ip-pools command</b>
CONFIG, feature dials, add ip-pool
CONFIG, feature dials, delete ip-pool

### GWCON, Feature Dials, Reset VC-Parameters Command

**Description:**

This command resets the Virtual Connection parameters and table size.

**Network Effect:**

If the table size is reduced, some virtual circuits may be terminated.

**Limitations:**

None.

The following table summarizes the DIALs Server configuration changes that are activated when the **GWCON, feature dials, reset vc-parameters** command is invoked:

<b>Commands whose changes are activated by the GWCON, feature dials, reset vc-parameters command</b>
CONFIG, feature dials, set vc-parameters

### GWCON, Feature Dials, Reset All Command

**Description:**

This command resets all parameters that can be reset through the DIALs reset commands.

**Network Effect:**

See the individual reset commands.

**Limitations:**

None.



The following table summarizes the Dial-In Access to LANs (DIALs) Server configuration changes that are activated when the **GWCON, feature dials, reset all** command is invoked:

Commands whose changes are activated by the <b>GWCON, feature dials, reset all</b> command
CONFIG, feature dials, add dhcp-server
CONFIG, feature dials, add ip-pool
CONFIG, feature dials, delete dhcp-server
CONFIG, feature dials, delete ip-pool
CONFIG, feature dials, enable dynamic-dns
CONFIG, feature dials, enable ip-address-assignment
CONFIG, feature dials, disable dynamic-dns
CONFIG, feature dials, disable ip-address-assignment
CONFIG, feature dials, set dhcp-gateway-address
CONFIG, feature dials, set ip-pools
CONFIG, feature dials, set vc-parameters

### CONFIG (Talk 6) Immediate Change Commands

DIALs Server supports the following CONFIG commands that immediately change the operational state of the device. These changes are saved and are preserved if the device is reloaded, restarted, or you execute a dynamically reconfigurable command.

Commands
CONFIG, feature dials, set dns
CONFIG, feature dials, set nbns
CONFIG, feature dials, set time-allowed

### Non-Dynamically Reconfigurable Commands

The following table describes the DIALs Server configuration commands that cannot be dynamically changed. To activate these commands, you need to reload or restart the device.

Commands
CONFIG, feature dials, set dial-out servername
CONFIG, feature dials, set laa
CONFIG, feature dials, set multi-chassis-mp
CONFIG, feature dials, disable dial-out dials
CONFIG, feature dials, disable dial-out Telnet
CONFIG, feature dials, enable dial-out dials
CONFIG, feature dials, enable dial-out Telnet

### Dial-Out Dynamic Reconfiguration Support

This section describes dynamic reconfiguration (DR) as it affects Talk 6 and Talk 5 commands.

## Configuring DIALs

### CONFIG (Talk 6) Delete Interface Command

Dial-out supports the CONFIG (Talk 6) **delete interface** command with no restrictions.

### GWCON (Talk 5) Activate Interface Command

Dial-out supports the GWCON (Talk 5) **activate interface** command with the following considerations:

- You cannot activate a dial-out net unless the base net is already active.
- You cannot activate a dial-out net unless the base net type is V34

All dial-out interface-specific commands are supported by the GWCON (Talk 5) **activate interface** command.

### GWCON (Talk 5) Reset Interface Command

Dial-out supports the GWCON (Talk 5) **reset interface** command with the following consideration:

You cannot reset a dial-out net if the base net has changed

All dial-out interface-specific commands are supported by the GWCON (Talk 5) **reset interface** command.

---

## Chapter 32. Using DHCP Server

This chapter describes how to use the DHCP Server. It includes the following sections:

- “Introduction to DHCP”
- “Concepts and Terminology” on page 493
- “DHCP Server and Lease Parameters” on page 496
- “DHCP Options” on page 496
- “Configuring IP for DHCP” on page 507
- “Sample DHCP Server Configuration” on page 509

---

### Introduction to DHCP

Dynamic Host Configuration Protocol (DHCP) is a client/server protocol that is based upon the Bootstrap Protocol (BOOTP). The DHCP server provides centrally controlled reusable IP addresses and other TCP/IP configuration information for DHCP clients. Its functionality can alleviate the burden that Network Managers have of distributing configuration information to new and existing users. This feature is compliant to RFC 2131 but supports many additional features not included in that document. There is also support for BOOTP clients as defined in RFC 951.

With DHCP, supporting clients can send broadcast DISCOVER messages to find DHCP servers in their network and subsequently be OFFERED their configuration data dynamically across the network. DHCP uses the well know BOOTP UDP ports (68 for the server and 67 for the client) to communicate requests and responses. DHCP clients and servers can use existing BOOTP relay agents to extend their service range. DHCP offers many advantages over statically configured networks, including the ability to support changing networks. Clients are only leased their IP addresses so when they no longer have a need for it or are moving to another subnet, the address can be RELEASED and made available for other clients to use.

### DHCP Operation

DHCP allows clients to obtain IP network configuration information, including an IP address, from a central DHCP server. DHCP servers control whether the addresses they provide to clients are allocated permanently or are leased for a specific time period. When a client receives a leased address, it must periodically request that the server revalidate the address and renew the lease.

The processes of address allocation , leasing, and lease renewal are all handled by the DHCP client and server programs and are transparent to end-users. The clients use RFC architected messages to accept and use the options served them by the DHCP server. For example:

1. The client broadcasts a message (containing its client ID) announcing its presence and requesting an IP address (DHCPDISCOVER message) and desired options such as subnet mask, domain name server, domain name and static route.
2. Optionally, if routers on the network are configured to forward DHCP and BOOTP messages (using BOOTP Relay), the broadcast message is forwarded to DHCP servers on the attached networks.
3. Each DHCP server that receives the client’s DHCPDISCOVER message sends a DHCPOFFER message to the client offering an IP address. The DHCP server checks for duplicate IP addresses on the network before issuing an offer. The server checks the configuration file to see if it should assign a static or dynamic

## Using DHCP Server

address to this client. In the case of a dynamic address, the server selects an address from the address pool, choosing the least recently used address. An address pool is a range of IP addresses to be leased to clients. In the case of a static address, the server uses a Client statement from the DHCP server configuration to assign options to the clients. Upon making the offer, the DHCP server reserves the offered address.

4. The client receives the offer message(s) and selects the server it wants to use. When a DHCP client receives an offer, it makes note of how many of the requested options are included in the offer. The DHCP client continues to receive offers from DHCP servers for a period of 4 seconds after the first offer is received, making note of how many of the requested options are included in each offer. At the end of that time, the DHCP client compares all offers and selects the one that meets its criteria.
5. The client broadcasts a message to indicate the server it selected and requests use of the IP address offered by that server (DHCPREQUEST message).
6. If a server receives a DHCPREQUEST message indicating that the client has accepted the server's offer, the server marks that address as leased. If the server receives a DHCPREQUEST message indicating that the client has accepted an offer from a different server, the server returns the address to the available pool. If no message is received within a specified time, the server returns the address to the available pool. The selected server sends an acknowledgment which contains additional configurations information to the client (DHCPACK message).
7. The client determines whether the configuration information is valid. Upon receipt of a DHCPACK message, the DHCP clients sends an Address Resolution Protocol (ARP) request to the supplied IP address to see if it is already in use. If it receives a response to the ARP request, the client declines (DHCPDECLINE message) the offer and initiates the process again. Otherwise, the client accepts the configuration information.
8. Accepting a valid lease, the client enters a BINDING state with the DHCP server, and proceeds to use the IP address and options. If the DHCP client is a Dynamic-Address client, the DHCP client notifies the Dynamic Domain Name Server of its host name-to-IP address mapping.

To DHCP clients that request options, the DHCP server typically provides options that include subnet mask, domain name server, domain name, static route, class-identifier (which indicates a particular vendor), and user class.

However a DHCP client can request its own, unique set of options. For example, Windows NT 3.5.1 DHCP clients are required to request options. The default set of client requested DHCP options provided by IBM includes subnet mask, domain name server, domain name, and static route. For option descriptions, see "DHCP Options" on page 496.

## Lease Renewals

The DHCP client keeps track of how much time is remaining on the lease. At a specified time prior to the expiration of the lease, usually when half of the lease time has passed, the client sends a renewal request, containing its current IP address and configuration information, to the leasing server. If the server responds with a lease offer, the DHCP client's lease is renewed.

If the DHCP server explicitly refuses the request, the DHCP client may continue to use the IP address until the lease time expires and then initiate the address request

process, including broadcasting the address request. If the server is unreachable, the client may continue to use the assigned address until the lease expires.

### Client Movement

One benefit of DHCP is the freedom it provides a client host to move from one subnet to another without having to know ahead of time what IP configuration information it needs on the new subnet. As long as the subnets to which a host relocates have access to a DHCP server, a DHCP client will automatically configure itself correctly to access those subnets.

In order for DHCP clients to reconfigure to access a new subnet, the client host must be rebooted. When a host restarts on a new subnet, the DHCP clients tries to renew its old lease with the DHCP server which originally allocated the address. The server refuses to renew the request since the address is not valid on the new subnet. Receiving no server response or instructions from the DHCP server, the client initiates the IP address request process to obtain a new IP address and access the network.

### Changing Server Options

With DHCP, you can make changes at the server, reinitialize the server, and distribute the changes to all the appropriate clients. A DHCP client retains DHCP option values assigned by the DHCP server for the duration of the lease. If you implement configuration changes at the server while a client is already up and running, those changes are not processed by the DHCP client until the clients attempts to renew its lease or until it is restarted.

**Note:** If the server does not contain a Hard File or Flash Storage card and it is reinitialized (using the `t 5 reset dhcp` command), the lease time information displayed by the router will be lost until the DHCP clients renew their lease.

### Number of DHCP servers

The number of servers that you need will depend largely on the number of subnets you have, the number of DHCP clients you plan to support, whether you use BOOTP Relay, and the lease time you choose. Keep in mind that the DHCP protocol does not currently define server-to-server communication. Thus, they cannot share information, nor can one DHCP server perform as a “hot backup” in the event the other one fails. DHCP clients send broadcast messages. By design, broadcast messages do not cross subnets. To allow the client’s messages to be forwarded outside its subnet, additional routers must be configured to forward DHCP requests using the BOOTP Relay agent. Otherwise, you will need to configure a DHCP server on each subnet.

### A Single DHCP server

If you choose to use a single DHCP server to serve hosts on a subnet, consider the effects if the single server fails. Generally, the failure of a server will affect only DHCP clients that are attempting to join the network. Typically, DHCP clients already on the network will continue operating unaffected until their lease expires. However, clients with a short lease time may lose their network access before the server can be restarted. To minimize the impact of server downtime if you have only one DHCP server for a subnet, you should choose a sufficiently long lease time to allow time to restart or respond to the failed DHCP server.

## Using DHCP Server

### Multiple DHCP servers

To avoid a single point of failure, you can configure two or more DHCP servers to serve the same subnet. If one server fails, the other can continue to serve the subnet. Each of the DHCP servers must be accessible either by direct attachment to the subnet or by using a BOOTP Relay agent.

Because two DHCP servers cannot serve the same addresses, address pools defined for a subnet must be unique across DHCP servers. Therefore, when using two or more DHCP servers to serve a particular subnet, the complete list of addresses for that subnet must be divided among the servers. For example, you could configure one server with an address pool consisting of 70% of the available addresses for the subnet and the other server with an address pool consisting of the remaining 30% of the available addresses.

Using multiple DHCP servers decreases the probability of having a DHCP related network access failure, but does not guarantee against it. If a DHCP server for a particular subnet fails, the other DHCP server may not be able to service all the requests from new clients which may, for example, exhaust the server's limited pool of available addresses.

However, you can bias which DHCP server exhausts its pool of addresses first. DHCP clients tend to select the DHCP server offering more options. To bias service toward the DHCP server with 70% of the available addresses, offer fewer DHCP options from the server holding 30% of the available addresses for the subnet.

### BOOTP Servers

If you already have BOOTP clients and servers in your network, you may want to consider replacing your BOOTP servers with DHCP servers. DHCP servers can optionally serve BOOTP clients the same IP configuration information as current BOOTP servers. If you cannot replace your BOOTP servers with DHCP servers and want to have both serve your network, the following precautions are recommended:

- Turn off BOOTP support in the DHCP server.
- Make sure your BOOTP servers and DHCP servers do not give out the same addresses.
- Configure the BOOTP Relay support in your routers to forward BOOTP broadcasts to both the appropriate BOOTP and DHCP servers.

A DHCP server allocates a permanent IP address to a BOOTP client. In the event that subnets are renumbered in such a way that a BOOTP assigned address is unusable, the BOOTP client must restart and obtain a new IP address.

### Special DHCP Clients

You may have DHCP clients or Network Servers which have individual or special administrative needs, such as:

- A Permanent Lease:  
You can assign permanent leases to designated hosts by specifying an infinite lease time. Also the DHCP server will allocate a permanent lease to BOOTP clients that explicitly request it as long as support for BOOTP clients is enabled. The DHCP server will also allocate a permanent lease to DHCP hosts that explicitly request it.
- A Specific IP Address:  
You can reserve a specific address and configuration parameters for a specific DHCP or BOOTP client host on a particular subnet.

- **Specific Configuration Parameters:**  
You can allocate specific configuration information to a client regardless of its subnet.
- **Manually Defined Workstations:**  
You should explicitly exclude addresses from DHCP subnets for existing hosts that do not use DHCP or BOOTP for configuring their IP network access. Although DHCP servers and clients automatically check to see if an IP address is in use before allocating or using it, they will not be able to detect addresses of manually defined hosts that are turned off or temporarily off the network. In that case, duplicate address problems may occur when a manually defined host reaccesses the network, unless its IP address is explicitly excluded.

## Lease Times

The default lease time is 24 hours. Keep in mind that the DHCP lease time can affect your network operation and performance:

- Short lease times will increase the amount of network traffic due to DHCP lease renewal requests. For example, if you set a lease time of 5 minutes, each client sends a renewal request about every 2.5 minutes.
- Lease times that are too long can limit the ability to reuse IP addresses. Very long lease times also delay configuration changes that occur when a client restarts or renews a lease.

The lease time you choose depends largely on your needs, including:

- The number of hosts to support compared to the number of available addresses. If you have more hosts than addresses, you may want to choose a short lease time of one to two hours. This will help ensure that unused addresses are returned to the pool as soon as possible.
- The time available to make network changes. Hosts receive changes to configuration information when they are restarted or renew their lease. Be sure to allow a timely and adequate window to make these changes. For example, if you usually make changes overnight, you might assign a lease time of 12 hours.
- The number of DHCP servers that are available. If you have only a few DHCP servers for a large network, you may want to choose a longer lease time to minimize the impact of server down time.

For complex networks that need to support a combination of host leasing requirements, you can define DHCP classes.

---

## Concepts and Terminology

The following concepts are used to describe the DHCP server function:

**Scope** The term scope, when discussing the DHCP server Configuration, will be used to identify what a certain parameter value pertains to. Figure 49 on page 494 illustrates the following scopes:

- Global option 1
- Global option 3
- Global class ClassA  
ClassA has redefined option 1, but will inherit the value of option 3 from the global scope.
- Global client ClientA  
ClientA has redefined option 3, but will inherit the value of option 1 from the global scope.

## Using DHCP Server

- subnet SubA
  - Redefines Option 1.
  - Inherits the value of Option 3 from the global scope.
  - Defines ClassB within the scope of SubA.  
It redefines the value of option 1, but will inherit the value of option 3 from SubA (which also happens to be inherited from the global scope).
  - Defines ClientB within the scope of SubA.  
ClientB has redefined option 3, but will inherit the value of option 1 from SubA.
- vendor-option vendorA  
Vendor-options are an exception. Vendor-options are independent and are not inherited outside of the vendor-option scope.

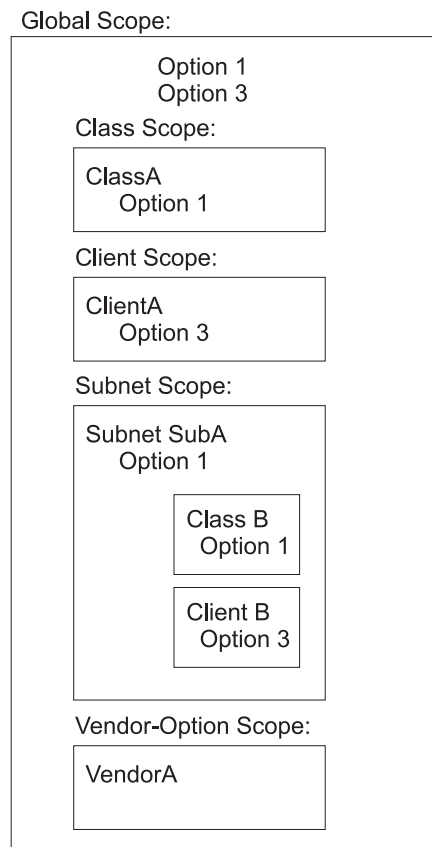

Figure 49. Scope Concepts

### Subnet

A subnet defines the parameters for an address pool administered by a DHCP server. An address pool is a range of IP addresses to be leased to clients. Parameters that can be specified include the lease time and other options for clients using the address pool. The lease time and other options can be inherited from the global scope.

### Subnet Groups

A subnet group is a way to identify multiple subnets that are to be grouped together on the same interface. All the subnets in a given group are given



the same subnet group name and a unique priority. The priority is used to determine the order addresses are given out according to the address policy the group is associated with. A subnet can belong to one of two address policies:

- Inorder

This policy is the default. The inorder policy administers addresses starting with the subnet with the lowest priority and ending with the subnet with the highest priority.

- Balance

The balance policy administers addresses from the group of defined subnets in a round-robin order. The first address is administered from the subnet with the lowest priority. The second address is administered from the subnet with the next lowest priority, and so on. When an address from the highest priority subnet has been administered, the policy returns to the subnet with the lowest priority until all addresses are exhausted from all the subnets in the group.

### Classes

A class defines the parameters for a user defined group of clients, administered by the DHCP server. Classes can be defined under the global or a subnet scope. When a class is defined within a subnet scope, the DHCP server will only serve clients in the class that are both located in the specified subnet and request the class. Only classes that are defined within a subnet's scope can specify a range of addresses. The range can be either a subset of the subnet range or can be equal to the subnet range. A client that requests an IP address from a class which has exhausted its range is offered an IP address from the subnet range, if available. The client is offered the options associated with the exhausted class.

### Clients

A client can be used to:

- Define a static IP address and DHCP options for a specific end station
- Exclude a specific endstation from service
- Exclude an IP address from a range of available IP addresses

Each client has a specified hardware type, client id and IP address. The hardware types are defined in RFC 1340 and are shown below. For all hardware types besides 0, the client ID is the hardware address of the endstation (or MAC address). For hardware type of 0, the client id is a character string. Typically, this would be a domain name.

When defining a client, you are prompted for either an IP address, *any* or *none*. If you define an IP address, that IP address is reserved for that client. If you choose *any*, then that client will be given any available IP address within that subnet. If you have several subnets records defined within the same subnet, each having a unique range, then a client that is configured with *any* will get the first available address within the subnet, not necessarily from the range of the specific subnet record that the client is defined under. If you choose *none*, then that end station will not be served any IP address at all. To exclude an IP address from being administered, you would define a client record with a hardware type and client id of 0.

Hardware types that are defined by RFC1340 and that pertain to the IBM 2212 are:

## Using DHCP Server

Hardware Type	Value
Reserved	0
Ethernet	1
IEEE 802 Networks (including Token Ring)	6

For the complete list, refer to RFC 1340.

---

## DHCP Server and Lease Parameters

The following DHCP server parameters can be defined at the global level:

- bootstrapservers
- canonical
- lease expire interval
- lease time default
- ping time
- support unlisted clients
- support bootp
- used ip address expire interval

See “Set” on page 536 for a description of these parameters.

---

## DHCP Options

DHCP allows you to specify options to provide additional configuration information to a client. The options are defined in RFC 2132 and various other RFCs.

## Option Formats

All options expect the configuration data to be in one of the following formats:

Format	Definition
<b>IP address</b>	A single IP address in dotted-decimal notation.
<b>IP addresses</b>	One or more IP addresses in dotted-decimal notation, separated by blanks.
<b>IP address pair</b>	Two IP addresses in dotted-decimal notation, separated by blanks.
<b>IP address pairs</b>	One or more IP address pairs, each pair separated from another by a blank.
<b>Boolean</b>	0 or 1 (True or False).
<b>Byte</b>	A decimal number between -128 and 127 (inclusive).
<b>Unsigned byte</b>	A decimal number between 0 and 255 (inclusive). You cannot specify a negative value for an unsigned byte.
<b>List of unsigned bytes</b>	One or more decimal numbers between 0 and 255 (inclusive) separated by blanks. You cannot specify a negative number for an unsigned byte.
<b>Short</b>	A decimal number between -32768 and 32767 (inclusive).

<b>Unsigned short</b>	A decimal number between 0 and 65535 (inclusive). You cannot specify a negative number for an unsigned short.
<b>List of unsigned shorts</b>	One or more decimal numbers between 0 and 65535 (inclusive) separated by blanks. You cannot specify a negative number for an unsigned short.
<b>Long</b>	A decimal value between -2147483648 and 2147483647 (inclusive).
<b>Unsigned long</b>	A decimal number between 0 and 4294967295 (inclusive). You cannot specify a negative number for an unsigned long.
<b>String</b>	A string of characters.
<b>N/A</b>	Indicates no specification is needed because the client generates this information.

Each DHCP option is identified by a numeric code.

Architected options 0 through 127 and option 255 are reserved for definitions by RFCs. The DHCP server, the DHCP client, or both server and client use options in this set. Some architected options can be modified by the administrator. Other options are for exclusive use by the client and server.

**Note:** Hexadecimal values are not allowed for architected options with known formats.

Options that the administrator cannot or should not configure at the DHCP server include:

- 52** Option Overload
- 53** DHCP message type
- 54** Server identifier
- 55** Parameter request list
- 56** Message
- 57** Maximum DHCP message size
- 60** Class identifier

Options 128 through 254 represent user-defined options that can be defined by administrators to pass information to the DHCP client to implement site-specific configuration parameters.

Additionally, IBM provides a set of IBM-specific options such as option 192: TXT RR

The format of a user-defined option is:

**Syntax:**

**option**            *code value*

where,

**code** Any option code from 1 through 254, except codes that are already defined in a RFC.

## Using DHCP Server

**value** Must always be a string. At the server, it can be an ASCII string or a hexadecimal string. At the client, however, it always appears as a hexadecimal string as passed to the processing program.

The server passes the specified value to the client. However, a program or command file must be created to process the value.

## Base Options Provided to the Client

The following base options are provided to the client. See “Option Formats” on page 496 for a description of the configuration format.

**1 Subnet Mask** This option is specified only at the DHCP server. The client's subnet mask, specified in a 32-bit dotted-decimal notation. Although not required, in most configurations the DHCP server should send option 1, subnet mask, to the DHCP clients. Client operation may be unpredictable if the client receives no subnet mask from the DHCP server and assumes a subnet mask that is not appropriate of the subnet. If not specified, the client used the default subnet masks:

- Class A network 255.0.0.0
- Class B network 255.255.0.0
- Class C network 255.255.255.0

Option format: IP addresses

**2 Time Offset** This options is specified only at the DHCP server. The offset (in seconds) of the client's subnet from Coordinated Universal Time (CUT). The offset is a signed 32-bit integer.

Option format: Long

**3 Router** This option is specified only at the DHCP server. IP addresses (in order of preference) of the routers on the client's subnet.

Option format: IP addresses

**4 Time Server** This option is specified only at the DHCP server. IP addresses (in order of preference) of the time servers available to the client.

Option format: IP addresses

**5 Name Server** This option is specified only at the DHCP server. IP addresses (in order of preference) of the IEN 116 name servers available to the client.

**Note:** This is not the Domain Name Server option. Use Option 6 to specify a Domain name server.

Option format: IP addresses

**6 Domain Name Server** This option is specified only at the DHCP server. IP addresses (in order of preference) of the Domain Name System servers available to the client.

Option format: IP addresses or un-numbered IP interfaceaddress (for example, 0.0.0.2)

**Note:** If dynamic-address is enabled in the IP configuration for a PPP interface, you may be able to retrieve a Primary and Secondary DNS address using IPCP from an Internet Service Provider (ISP). To pass these DNS addresses along to the DHCP clients, you must configure

option 6 with an un-numbered IP interface address (such as 0.0.0.n) that corresponds to the Dynamic-Address interface. The DHCP server will convert this to the value retrieved from the ISP when the client sends a request. Enabling Simple-Internet-Access in the IP configuration will configure option 6 with the un-numbered IP interface automatically. Any client requesting its configuration information from this Server prior to the PPP interface activating, will be offered a shortened lease time (3 minutes) to allow time for the PPP connection and IPCP to complete. After the DNS addresses are learned, configured lease times will be offered.

- 7 Log Server** This option is specified only at the DHCP server. IP addresses (in order of preference) of the MIT-LCS UDP Log servers available to the client.
- Option format: IP addresses
- 8 Cookie Server** This option is specified only at the DHCP server. IP addresses (in order of preference) of the Cookie, or quote-of -the-day servers available to the client.
- Option format: IP addresses
- 9 LPR Server** This option can be specified at both the DHCP client and DHCP server. However, if specified only at the DHCP client, the configuration will be incomplete. IP addresses (in order of preference) of the line printer servers available to the client. Option 9 eliminates the need for clients to specify the LPR\_SERVER environment variable.
- Option format: IP addresses
- 10 Impress Server** This option is specified only at the DHCP server. IP addresses (in order of preference) of the Imagen Impress servers available to the client.
- Option format: IP addresses
- 11 Resource Location Server** This option is specified only at the DHCP server. IP addresses (in order of preference) of the Resource Location (RLP) servers available to the client. RLP servers allow clients to locate resources that provide a specified service, such as a domain name server.
- Option format: IP addresses
- 12 Host Name** This option can be specified at both the DHCP client and the DHCP server. If the DHCP client does not provide a host name, the DHCP server ignores option 12. Host name of the client (which may include the local domain name). The minimum length for the host name option is 1 octet and the maximum is 32 characters. See RFC 1035 for character set restrictions.
- Option format: String
- 13 Boot File Size** This option is specified only at the DHCP server. The length (in 512-octet blocks) of the default boot configuration file for the client.
- Option format: Unsigned short
- 14 Merit Dump File** This option is specified only at the DHCP server. The path name of the merit dump file in which the client's core image is stored if the client crashes. The path is formatted as a character string consisting of characters from the Network Virtual Terminal (NVT) ASCII character set. The minimum length is 1 octet.

## Using DHCP Server

Option format: String

- 15 Domain Name** This option is specified at both the DHCP client and the DHCP server. If no value is specified at the DHCP server in option 15, the client is required to provide a value for option 12, host name, and option 15, domain name. This statement may appear within the global scope, or with a Subnet, Class or Client scope.

Option format: String

- 16 Swap Server** This option is specified only at the DHCP server. The IP address of the client's swap server.

Option format: IP address

- 17 Root Path** This option is specified only at the DHCP server. The path that contains the client's root disk. The path is formatted as a character string consisting of characters from the NVT ASCII character set. The minimum length is 1 octet.

Option format: String

- 18 Extension Path** This option is specified only at the DHCP server. The extension path option specifies a string that can be used to identify a file that is retrievable using the Trivial File Transfer Protocol (TFTP). The minimum length is 1 octet.

Option format: String

## IP Layer Parameters per Host Options

- 19 IP Forwarding** This option is specified only at the DHCP server. Enable (1) or disable (0) forwarding by the client of its IP layer packets.

Option format: Boolean

- 20 Non-Local Source Routing** This option is specified only at the DHCP server. Enable (1) or disable (0) forwarding by the client of its IP layer data grams with non-local source routes.

Option format: Boolean

- 21 Policy Filter** This option is specified only at the DHCP server. IP address-net mask pair used to filter data grams with non-local source routes. Any data gram whose next hop address does not match one of the filter pairs is discarded by the client. The minimum length for the policy filter option is 8 octets.

Option format: IP address pairs

- 22 Maximum Data gram Reassembly Size** This option is specified only at the DHCP server. Maximum size data gram the client will reassemble. The minimum value is 576.

Option format: Unsigned short

- 23 Default IP Time-to-Live** This option is specified only at the DHCP server. Default time-to-live (TTL) the client uses on outgoing data grams. TTL is an octet with a value between 1 and 255.

Option format: Unsigned byte

- 24 Path MTU Aging Timeout** This option is specified only at the DHCP server. Timeout in seconds used to age Path Maximum Transmission Unit (MTU) values discovered by the mechanism that is described in RFC 1191.

Option format: Unsigned long

- 25 Path MTU Plateau Table** This option is specified only at the DHCP server. Table of MTU sizes to sue in Path MTU discover as defined in RFC 1191. The minimum MTU value is 68. The minimum length for the path MTU plateau table option is 2 octets. The length must be a multiple of 2.

Option format: Unsigned short

## IP Layer Parameters per Interface Options

- 26 Interface MTU** This option is specified only at the DHCP server. Maximum Transmission Unit (MTU) to sue on this interface. The minimum MTU value is 68.

Option format: Unsigned short

- 27 All Subnets are Local** This option is specified only at the DHCP server. Client assumes (1) or does not assume (0) all subnets use the same Maximum Transmission Unit (MTU). A value of 0 means the client assumes some subnets have smaller MTUs.

Option format: Boolean

- 28 Broadcast Address** This option is specified only at the DHCP server. Broadcast address used on the client's subnet.

Option format: IP address

- 29 Perform Mask Discovery** This option is specified only at the DHCP server. Clients performs (1) or does not perform (0) subnet mask discovery using Internet Control Message Protocol (ICMP).

Option format: Boolean

- 30 Mask Supplier** This option is specified only at the DHCP server. Client responds (1) or does not respond (0) to subnet mask requests using Internet Control Message Protocol (ICMP).

Option format: Boolean

- 31 Perform Router Discovery** This option is specified only at the DHCP server. Client solicits (1) or does not solicit (0) routers using router discovery as defined in RFC 1256.

Option format: Boolean

- 32 Router Solicitation Address** This option is specified only at the DHCP server. Address to which a client transmits router solicitation requests.

Option format: IP address

- 33 Static Route** This option is specified only at the DHCP server. Static routes (designation address-router pairs in order of preference) the client installs in its routing cache. The first address is the destination address and the second address is the router for the destination. Do not specify 0.0.0.0 as a default route destination.

Option format: IP address pairs

## Link Layer Parameters per Interface Options

- 34 Trailer Encapsulation** This option is specified only at the DHCP server. Client negotiates (1) or does not negotiate (0) the use of trailers when using Address Resolution Protocol (ARP). For more information see RFC 893.

## Using DHCP Server

Option format: Boolean

- 35 **ARP Cache Timeout** This option is specified only at the DHCP server. Timeout in seconds for Address Resolution Protocol (ARP) cache entries.

Option format: Unsigned long

- 36 **Ethernet Encapsulation** This option is specified only at the DHCP server. For an Ethernet interface, client uses IEEE 802.3 (1) Ethernet encapsulation described in RFC 1042 or Ethernet V2 (0) encapsulation described in RFC 894.

Option format: Boolean

## TCP Parameter Options

- 37 **TCP Default TTL** This option is specified only at the DHCP server. Default time-to-live (TTL) the client uses for sending TCP segments.

Option format: Unsigned byte

- 38 **TCP Keep-alive Interval** This option is specified only at the DHCP server. Interval in seconds the client waits before sending a keep-alive message on a TCP connection. A value of 0 indicates the client does not send keep-alive messages unless requested by the application.

Option format: Unsigned long

- 39 **TCP Keep-alive Garbage** This option is specified only at the DHCP server. Client sends (1) or does not send (0) TCP keep-alive messages that contain an octet of garbage for compatibility with previous implementations.

Option format: Boolean

## Application and Service Parameter Options

- 40 **Network Information Service Domain** This option is specified only at the DHCP server. The client's Network Information Service (NIS) domain. The domain is formatted as a character string consisting of characters from the NVT ASCII character set. The minimum length is 1 octet.

Option format: String

- 41 **Network Information Service Domain** This option is specified only at the DHCP server. IP addresses (in order of preference) of Network Information Service (NIS) servers available to the client.

Option format: IP addresses

- 42 **Network Time Protocol Servers** This option is specified only at the DHCP server. IP addresses (in order of preference) of Network Time Protocol (NTP) servers available to the client.

Option format: IP addresses

- 43 **Vendor-Specific Information** Option 43 is specified only at the DHCP server, which returns this option to a client that sends option 60, Class Identifier. This information option is used by clients and servers to exchange vendor-specific information, which is specified in the vendor-option definition. Considerations in using Option 43 to encapsulate vendor information are:

- To permit interoperability between clients and servers from different vendors, each vendor must clearly document its option 43 content using the standard format from RFC 2132.



- Each vendor should specify the specific options that can be encapsulated within option 43 in a form that DHCP servers from another vendor can easily implement. For example, the vendor should:
  - Represent those options either in a data types already defined for DHCP options or in other well-defined data types.
  - Choose options that can be readily encoded in configuration files for exchange with servers provided by other vendors.
  - Be readily supportable by all servers.

Servers that cannot interpret the vendor-specific information sent by a client must ignore it. Clients that do not receive desired vendor-specific information should attempt to operate without it. Refer to RFC 2131 and RFC 2132 for additional information about this option.

**Note:** Because of these considerations, IBM instead uses options 192 and 200 for IBM-specific options.

Option format: String

- 44 NetBIOS over TCP/IP Name Server** This option is specified only at the DHCP server. IP addresses (in order of preference) of NetBIOS name servers (NBNS) available to the client.

Option format: IP addresses

- 45 NetBIOS over TCP/IP Datagram Distribution Server** This option is specified only at the DHCP server. IP addresses (in order of preference) of NetBIOS data gram distribution (NBDD) name servers available to the client.

Option format: IP addresses

- 46 NetBIOS over TCP/IP Node Type** This option is specified only at the DHCP server. Node type used for NetBIOS over TCP/IP configurable clients as described in RFC 1001 and RFC 1002. Values to specify client types include:

- 0x1 B-node
- 0x2 P-node
- 0x4 M-note
- 0x8 H-node

Option format: Unsigned byte

- 47 NetBIOS over TCP/IP Scope** This option is specified only at the DHCP server. NetBIOS over TCP/IP scope parameter for the client, as specified in RFC 1001/1002. The minimum length is 1 octet.

Option format: Unsigned byte

- 48 X Window System Font Server** This option is specified only at the DHCP server. IP addresses (in order of preference) of X Window System font servers available to the client.

Option format: IP addresses

- 49 Window System Display Manager** This option is specified only at the DHCP server. IP addresses (in order of preference) of systems running X Window System Display Manager available to the client.

Option format: IP addresses

### DHCP Extensions Options

- 50 Requested IP Address** This option is specified only at the DHCP client. The DHCP server can refuse a DHCP client request for a specific IP address. Allows the client to request (DHCPDISCOVER) a particular IP address.
- Option format: N/A
- 51 IP Address Lease Time** This option can be specified at both the DHCP client and the DHCP server. The DHCP client can use option 51 to override the defaultLeaseInterval value the DHCP server offers. Allows the client to request (DHCPDISCOVER or DHCPREQUEST) a lease time for an IP address. In a reply (DHCPOFFER), a DHCP server uses the option to offer a lease time. This option may be specified within the global, subnet, class or client scope. Use X'ffffff' to indicate an infinite (permanent) lease.
- Option format: Unsigned long
- 58 Renewal (T1) Time Value** This option is specified only at the DHCP server. Interval in seconds between the time the server assigns an address and the time the client transitions to the renewing state.
- Option format: Unsigned long
- 59 Rebinding (T2) Time Value** This option is specified only at the DHCP server. Interval in seconds between the time the server assigns an address and the time the clients enters the rebinding state.
- Option format: Unsigned long
- 60 Class-Identifier** This option is specified only at the DHCP client. This information is generated by the client and does not have to be specified. Type and configuration of the client, supplied by the client to the server. For example, the identifier may encode the client's vendor-specific hardware configuration. The information is a string of *n* octets, interpreted by servers. For example: hex: X'01' X'02' X'03'. Servers not equipped to interpret the class-specific information sent by a client must ignore it. The minimum length is 1 octet.
- Option format: N/A
- 61 Client Identifier** This option can be specified at both the DHCP client and the DHCP server. The DHCP client can use option 61 to specify the unique client identifier. The DHCP server can use option 61 to index the database of address bindings. This value is expected to be unique for all clients in an administrative domain.
- Option format: String
- 62 NetWare/IP Domain Name** This option is specified only at the DHCP server. Netware/IP Domain Name. The minimum length is 1 octet and the maximum length is 255
- Option format: String
- 63 NetWare/IP** This option is specified only at the DHCP server. A general purpose option code used to convey all the NetWare/IP related information except for the NetWare/IP domain name. A number of NetWare/IP sub-options will be conveyed using the option code. The minimum length is 1 and the maximum length is 255.
- Option format: String

- 64 NIS domain Name** This option is specified only at the DHCP server. Network Information Service (NIS)+ V3 client domain name. The domain is formatted as a character string consisting of characters from the NVT ASCII character set. Its minimum length is 1.
- Option format: String
- 65 NIS Servers** This option is specified only at the DHCP server. IP addresses (in order of preference) of Network Information Service (NIS+ V3 servers available to the client.
- Option format: IP addresses
- 66 Server Name** This option is specified only at the DHCP server. Trivial File Transfer Protocol (TFTP) server name used when the “sname” field in the DHCP header has been used for DHCP options.
- Option format: String
- 67 Boot File Name** This option is specified only at the DHCP server. Name of the boot file when the file field in the DHCP header has been used for the DHCP options. The minimum length is 1.
- Note:** Use this option to pass a boot file name to a DHCP client. The boot file name is required to contain the fully-qualified path name and be less than 128 characters in length. For example: option 67 c:\path\boot\_file\_name. This file contains information that can be interpreted in the same way as the 64-octet vendor-extension field within the BOOTP response, with the exception that the file length is limited to 128 characters by the BootP header.
- Option format: String
- 68 Home Address** This option is specified only at the DHCP server. IP addresses (in order of preference) of the mobile IP home agents available to the client. The option enables a mobile host to derive a Mobile home address, and determine the subnet mask for the home network. The usual length will be four octets, containing a single home agent’s home address, but the length can be zero. A zero length indicates that no home agents are available.
- Option format: IP addresses
- 69 SMTP Servers** This option is specified only at the DHCP server. IP addresses (in order of preference) of the Simple Mail Transfer Protocol (SMTP) servers available to the client.
- Option format: IP addresses
- 70 POP3 Server** This option is specified only at the DHCP server. IP addresses (in order of preference) of the Post Office Protocol (POP) servers available to the client.
- Option format: IP addresses
- 71 NNTP Server** This option is specified only at the DHCP server. IP addresses (in order of preference) of the Network News Transfer Protocol (NNTP) servers available to the client.
- Option format: IP addresses

## Using DHCP Server

- 72 WWW Server** This option is specified only at the DHCP server. IP addresses (in order of preference) of the World Wide Web (WWW) servers available to the client.  
Option format: IP addresses
- 73 Finger Server** This option is specified only at the DHCP server. IP addresses (in order of preference) of the Finger servers available to the client.  
Option format: IP addresses
- 74 IRC Server** This option is specified only at the DHCP server. IP addresses (in order of preference) of the Internet Relay Chat (IRC) servers available to the client.  
Option format: IP addresses
- 75 StreetTalk Server** This option is specified only at the DHCP server. IP addresses (in order of preference) of the StreetTalk servers available to the client.  
Option format: IP addresses
- 76 STDA Server** This option is specified only at the DHCP server. IP addresses (in order of preference) of the StreetTalk Directory Assistance (STDA) servers available to the client.  
Option format: IP addresses
- 77 User Class** This option is specified only at the DHCP client. DHCP clients use option 77 to indicate to DHCP servers what class the host is a member of. The user class must be manually entered in the \DHCPD.CFG file as the value for option 77 in order to receive parameters defined for the class at a DHCP server. The DHCPD.CFG file is located in the ONDEMAND\SERVER\ETC directory.  
Option format: String
- 78 Directory Agent** This option is specified only at the DHCP server. The Dynamic Host Configuration Protocol provides a framework for passing configuration information to hosts on a TCP/IP network. Entities using the Service Location Protocol need to find out the address of Directory Agents in order to transact messages. In certain other instances they may need to discover the correct scope and naming authority to be used in conjunction with the service attributes and URLs which are exchanged using the Service Location Protocol. A directory agent has a particular scope, and may have knowledge about schemes defined by a particular name authority.  
Option format: IP address
- 79 Service Scope** This option is specified only at the DHCP server. This extension indicates a scope that should be used by a service agent, when responding to Service Request messages as specified by the Service Location Protocol.  
Option format: String
- 80 Naming Authority** This option is specified only at the DHCP server. This extension indicates a naming authority, which specifies the syntax for schemes that may be used in URLs for use by entities with the Service Location Protocol.

Option format: String

## IBM-specific Options

IBM provides a set of IBM-specific options by defining options within the user-defined range (128-254). These options are used instead of defining a vendor option (option 43) for IBM. It is recommended that you do not redefine these options.

- 192** **TXT RR** If this option is specified at the DHCP server, the DHCP client user is required to complete the system administrator information fields. Note: This option is only supported by TCP/IP Version 4.1 for OS/2 clients. This option provides up to four required text labels or entry fields the system administrator can specify, such as the name of a user, the user's phone number, or other fields that the DDNS Client configuration program prompt the user for. These fields allow the system administrator to identify the actual person who configured the host name or other data. The DDNS configuration program does not display these fields unless the system administrator specifies them. This information is stored in a text record in the DNS. The pairs of field labels and data are required to fit within a single TXT resource record. The space available is divided evenly between the pairs. The value is also updated in file DDNSCLI.CFG on the Dynamic-Address client.

Option format: String

## Vendor Options

The DHCP protocol provides a way to supply vendor-specific information to a DHCP client using RFC-architected options 43 and 60.

- 60** **Option 60** is configured at a DHCP client and sent to the DHCP server to identify the client as one from a specific vendor.
- 43** **Option 43** is configured at the DHCP server to define the vendor-specific information to be returned to the client in response to the client's option 60 request. For the Common Code DHCP server, option 43 is configured using the add vendor-option command. A vendor-option is only defined within the global scope. The vendor option consists of the name of the vendor and the option data. The option data has two formats:

### Hex data

This is entered with the vendor name when the add vendor-option command is issued. The hex data must be entered as a hex string with blanks between the bytes: "01 AA 55"

### Options

Any DHCP option can be added to a vendor-option scope by the add option command.

**Note:** Hex data and options are mutually exclusive in a vendor definition. You can define one or the other, but not both.

---

## Configuring IP for DHCP

In order for the DHCP server to successfully assign IP addresses and configuration information for clients on an added subnet, IP may have to be configured appropriately. This is necessary when the DHCP server is directly connected to a subnet that it is configured to support.

## Using DHCP Server

If a BOOTP relay agent is being used to forward DHCP request messages to this DHCP server, there may not be any required IP configuration to support a subnet that is not directly connected to the server.

## Adding an IP Address

An IP address which falls within the DHCP configured subnet will need to be added to the connecting interface.

### Example:

- DHCP has added a subnet as follows:

```
DHCP Server config>list subnet all
subnet      subnet      subnet      starting      ending
name        address     mask        IP Addr       IP Addr
-----
net-one     192.168.8.0 255.255.255.0 192.168.8.2   192.168.8.50
```

- IP will require the following:

```
IP config>add address
Which net is this address for [0]? 0
New address []? 192.168.8.1
Address mask [255.255.255.0]?
```

```
IP config>list add
IP addresses for each interface:
intf  0  192.168.8.1  255.255.255.0  Local wire broadcast, fill 1
intf  1                                     IP disabled on this interface
intf  2  0.0.0.2      255.255.255.255  Local wire broadcast, fill 1
intf  3                                     IP disabled on this interface
```

## Using IP Simple-Internet-Access

If Simple-Internet-Access is enabled in IP and DHCP has not previously been configured, the following configuration will be automatically generated in the DHCP server. Simple-Internet-Access will also automatically configure the NAT feature and other IP filters and access controls. If DHCP is already configured there will be no changes/additions to the DHCP configuration. Refer to Using Simple Internet Access in the “Using IP” chapter in *Protocol Configuration and Monitoring Reference Volume 1* for more information and restrictions.

- IP has been configured as follows:

```
IP config>enable simple-internet-access
Interface to Service Provider [0]? 3
SIMPLE-INTERNET-ACCESS enabled on interface 3
```

```
IP config>add address
Which net is this address for [0]? 0
New address []? 192.168.8.1
Address mask [255.255.255.0]?
```

```
IP config>list add
IP addresses for each interface:
intf  0  192.168.8.1  255.255.255.0  Local wire broadcast, fill 1
intf  1                                     IP disabled on this interface
intf  2                                     IP disabled on this interface
intf  3  0.0.0.3      255.255.255.255  Local wire broadcast, fill 1
                                           SIMPLE-INTERNET-ACCESS Enabled
```

- DHCP server will have the following configuration generated:

```
DHCP Server config> list global
.
.
DHCP Server enabled: Yes
.
```

```

DHCP Server config>list subnet all
subnet      subnet      subnet      starting      ending
name        address     mask        IP Addr      IP Addr
-----
simple-net   192.168.8.0 255.255.255.0 192.168.8.2 192.168.8.50

DHCP Server config>list option subnet
Enter the subnet name []? simple-net
option      option
code        data
-----
1           255.255.255.0
3           192.168.8.1
6           0.0.0.3

```

---

## Sample DHCP Server Configuration

### ASCII Text File

This section provides a typical DHCP server configuration in an ASCII text format. This example is strictly for the purpose of illustration, to show a configuration in a format that may be familiar to you. The IBM 2212 does not support ASCII configurations.

You can use the blocked numbers (**1**) to relate the functions described in this ASCII example to the equivalent talk 6 configuration shown in "OPCON (Talk 6) Configuration" on page 510.

#### **1** Configuration of Server parameters

```

leaseTimeDefault      120                # 120 minutes
leaseExpireInterval   20 seconds
supportBOOTP          yes
supportUnlistedClients yes

```

#### **2** Global options. Passed to every client unless overridden at a lower scope.

```

option 15      "raleigh.ibm.com"      # domain name
option 6       9.67.1.5      # dns server

class manager
{
  option 48    6.5.4.3
  option 9     9.37.35.146
  option 210   "manager_authority" # site specific option given to all managers
}

```

#### **3** Vendor-options

```

vendor XI-clients hex"01 02 03"

vendor XA-clients
{
  option 23 100 # IP TTL
}

```

#### **4** A typical subnet

```

subnet 9.2.23.0 255.255.255.0 9.2.23.120-9.2.23.126
{
  option 28      9.2.23.127      # broadcast address
}

```

## Using DHCP Server

```
option 9 5.6.7.8
option 51 200
```

**5** class manager defined at the subnet scope. Option 9 here will override the option 9 specified in the global manager class.

```
class manager
{
    option 9 9.2.23.98
}
```

**6** Programmers have their own subnet range

```
class developers 9.2.23.125-9.2.23.126
{
    option 51 -1 # infinite lease.
    option 9 9.37.35.1 # printer used by the developers
}
}
```

**7** Example of a client that will accept any address but will have its own set of options.

```
client 6 0x10005aa4b9ab ANY
{
    option 51 999
    option 1 255.255.255.0
}
}
```

**8** Exclude an address from service.

```
client 0 0 9.2.23.121
```

## OPCON (Talk 6) Configuration

The following is an example of the same configuration using talk 6.

**1** Configuration of Server parameters

```
Config>f dhcp-server
DHCP server user configuration
DHCP Server config> enable dhcp
DHCP Server config>
```

```
DHCP Server config> set lease-time-default hours 2
DHCP Server config>set lease-expire-interval seconds 20
DHCP Server config>set support-bootp yes
DHCP Server config>set support-unlisted-clients global yes
```

```
DHCP Server config>li glob
DHCP server Global Parameters
=====
```

DHCP server enabled: Yes

Balance: No subnet groups defined

Inorder: No subnet groups defined

Canonical: No

Lease Expire Interval: 20 second(s)  
Lease Time Default: 2 hour(s)

Support BOOTP Clients: Yes



```

Bootstrap Server: Not configured

Support Unlisted Clients: Yes

Ping Time: 1 second(s)
Used IP Address Expire Interval: 15 minute(s)

```

**2** Global options. Passed to every client unless overridden at a lower scope.

```

DHCP Server config>add option global 15 raleigh.ibm.com
DHCP Server config>add option global 6 9.67.1.5

DHCP Server config>li option global
option option
code data
-----
15 raleigh.ibm.com
6 9.67.1.5

DHCP Server config>add class global
Enter the class name []? manager
Class record with name manager has been added

DHCP Server config>add option class-global
Enter the class name []? manager
Enter the option code [1]? 48
Enter the option data []? 6.5.4.3

DHCP Server config>add option class-global 9 9.37.35.146
DHCP Server config>add option class-global manager 210 manager_authority

DHCP Server config>li class global manager
class
name
-----
manager

Number of Options: 3
option option
code data
-----
48 6.5.4.3
9 9.37.35.146
210 manager_authority

```

**3** Vendor-options

```

DHCP Server config>add vendor-option XI-client
Enter the vendor hex data []? 01 02 03
Vendor-option record with name XI-client has been added

DHCP Server config> add vendor-option XA-client
Enter the vendor hex data []?
Vendor-option record with name XA-client has been added
DHCP Server config> add option vendor-option XA-client 23 100

DHCP Server config>li vendor-option all
vendor hex
name data
-----
XI-client 01 02 03
XA-client
DHCP Server config>li vendor-option det XA-client
vendor hex
name data
-----

```

## Using DHCP Server

XA-client

Number of Options: 1

option code	option data
----------------	----------------

23	100
----	-----

### 4 A typical subnet

DHCP Server config>**add subnet**

Enter the subnet name []? **sub1**

Enter the IP subnet []? **9.2.23.0**

Enter the IP subnet mask [255.255.255.0]?

Enter start of IP address range [9.2.23.1]? **9.2.23.120**

Enter end of IP address range [9.2.23.150]? **9.2.23.126**

Enter the subnet group name []?

Subnet record with name sub1 has been added

DHCP Server config>

DHCP Server config> **add option subnet**

Enter the subnet name []? **sub1**

Enter the option code []? **28**

Enter the option data []? **9.2.23.127**

DHCP Server config> **add option subnet 9 5.6.7.8**

DHCP Server config>**add option subnet sub1 51 200**

DHCP Server config>**add class subnet**

Enter the subnet name []? **sub1**

Enter the class name []? **manager**

Enter start of IP address range []?

Class record with name manager has been added

DHCP Server config>**add option class-subnet sub1 manager**

Enter the option code [1]? **9**

Enter the option data []? **9.2.23.98**

### 6 Programmers have their own subnet range

DHCP Server config>**add class subnet**

Enter the subnet name []? **sub1**

Enter the class name []? **developers**

Enter start of IP address range []? **9.2.23.125**

Enter end of IP address range []? **9.2.23.126**

Class record with name developers has been added

DHCP Server config>**add option class-subnet sub1 developers 51 -1**

DHCP Server config>**add option class-subnet sub1 developers 9 9.37.35.1**

DHCP Server config>**li subnet detailed sub1**

subnet name	subnet address	subnet mask	starting IP Addr	ending IP Addr
sub1	9.2.23.0	255.255.255.0	9.2.23.120	9.2.23.126

Number of Classes: 2

class name
---------------

manager
---------

Number of Options: 1

option code	option data
----------------	----------------

```

-----
9      9.2.23.98
developers
starting IP address: 9.2.23.125
ending   IP address: 9.2.23.126

Number of Options: 2
option  option
code    data
-----
51      -1
9      9.37.35.1

Number of Options: 3
option  option
code    data
-----
28      9.2.23.127
9      5.6.7.8
51      200

```

**7** Example of a client that will accept any address but will have its own set of

```

DHCP Server config>add client global
Enter the client name []? any-addr
Enter the client's hardware type (0 - 21) [1]? 6
Enter the client ID (MAC address or string) []? 10005aa4b9ab
Enter the client's IP address (IP address, any, none) []? any

DHCP Server config>add option client-global any-addr 51 999
DHCP Server config>add option client-global any-addr 1 255.255.255.0

```

**8** Exclude an address from service.

```

Enter the client name []? excl-addr
Enter the client's hardware type (0 - 21) [1]? 0
Enter the client ID (MAC address or string) []? 0
Enter the client's IP address (IP address, any, none) []? 9.2.23.121

DHCP Server config>li cli all
client      client  client      attached  IP
name        type   identifier  to subnet address
-----
any-addr    6      10005aa4b9ab      Any
excl-addr   0      0                  9.2.23.121

DHCP Server config>li client global any-addr
client      client  client      IP
name        type   identifier  address
-----
any-addr    6      10005aa4b9ab      Any

Number of Options: 2
option  option
code    data
-----
51      999
1      255.255.255.0

```

## Using DHCP Server

---

## Chapter 33. Configuring and Monitoring DHCP Server

This chapter describes how to use the DHCP server configuration and operating commands and includes the following sections:

- “Accessing the DHCP Server Configuration Environment”
- “DHCP Server Configuration Commands”
- “Accessing the DHCP Server Monitoring Environment” on page 543
- “DHCP Server Monitoring Commands” on page 544
- “DHCP Dynamic Reconfiguration Support” on page 547

---

### Accessing the DHCP Server Configuration Environment

Use the following procedure to access the DHCP server *configuration* process.

1. At the OPCODE prompt, enter **talk 6**. For example:

```
* talk 6
Config>
```

After you enter the **talk 6** command, the Config prompt (Config>) displays on the terminal. If the prompt does not appear when you first enter configuration, press **Return** again.

2. At the Config prompt, enter the **feature dhcp-server** command to get to the DHCP Server config> prompt.

---

### DHCP Server Configuration Commands

Table 60. DHCP Server Configuration Command Summary

Command	Function
? (Help)	Displays all the commands available for this command level or lists the options for specific commands (if available). See “Getting Help” on page xxxii.
Add	Adds a class, client, subnet, or vendor-option.
Change	Changes the definition of a class, client, subnet, or vendor-option.
Default	Returns certain global variables to their default values.
Delete	Deletes a class, subnet, or vendor-option.
Disable	Disables DHCP Server globally.
Enable	Enables DHCP Server globally.
List	Lists definitions of a class, client, globals, subnet, or vendor-option.
Set	Sets definitions for global parameters or options under a specified scope.
Exit	Returns you to the previous command level. See “Exiting a Lower Level Environment” on page xxxii.

#### Add

Use the **add** command to add a class, subnet or vendor-option.

#### Syntax:

```
add class
      client
      option
      subnet
      vendor-option
```

## DHCP Server Configuration Commands (Talk 6)

**class** *scope [subnet\_name] class\_name [range\_start] [range\_end]*

Defines a class.

**scope** Specifies the scope in which the class is being added.

**Valid Values:** global or subnet

**Default Value:** None

**subnet\_name**

This is valid only if the **scope** is *subnet*. Indicates the name of the subnet to which the class is being added.

**Valid Values:** Any existing subnet name

**Default Value:** None

**class-name**

Indicates the name of the class.

**Valid Values:** An ASCII string up to 40 characters in length

**Default Value:** None

**range-start**

This is valid only if the **scope** is *subnet*. Specifies the starting IP address for the IP address pool to which clients will be assigned.

**Valid Values:** Any valid IP address within the range of the subnet to which the class is being added.

**Default Value:** The first IP address of the subnet range belonging to the specified subnet.

**range-end**

This is valid only if the **scope** is *subnet*. Specifies the ending IP address for the IP address pool to which clients will be assigned.

**Valid Values:** Any valid IP address within the range of the subnet to which the class is being added. This value must be greater than the value specified for **range-start**.

**Default Value:** The starting IP address plus 5 of the subnet range belonging to the specified subnet. If the resulting IP address is no longer within the subnet range, then the default is the ending IP address of the subnet range.

**Example:**

```
DHCP Server config> add class global
Enter class name? ClassA
```

```
DHCP Server config> add class subnet
Enter the subnet name[]? subA
Enter class name[]? ClaA
Enter start of IP address range[10.1.1.1]?
Enter end of IP address range[10.1.1.6]?
```

**client** *scope [subnet\_name] client\_name id-type id-value address*

Defines a client

**scope** Specifies the scope in which the client is being added.

**Valid Values:** global or subnet

**Default Value:** None

## DHCP Server Configuration Commands (Talk 6)

### subnet-name

Valid only if the **scope** is *subnet*. Specifies the name of the subnet to which the client is being added.

**Valid Values:** Any existing subnet name

**Default Value:** None

### client-name

Indicates the name of the client.

**Valid Values:** Any 10-character ASCII string

**Default Value:** None

### id-type

Indicates the hardware type of the client. Hardware types defined in RFC 1340 that are applicable to the IBM 2212 are shown below as valid values.

**Valid Values:**

**0** Unspecified. Indicates a symbolic name for the client.

**1** Ethernet

**6** IEEE 802 networks (including 802.5 Token Ring)

**Default Value:** 1

### id-value

Specifies the client identifier. If the **id-type** is *0*, then the **id-value** is a 64-character string. Otherwise, the **id-value** is a MAC address.

**Note:** An **id-type** of *0* and an **id-value** of *0* indicates that the specified IP address should not be distributed by the server.

**Valid Values:** 0 or any valid MAC address (12 hexadecimal digits)

**Default Value:** None

### address

Specifies either the IP address to be supplied to the client or a character string indicating that the client will not be serviced or that the client can be supplied with any address from the IP address pool.

**Valid Values:**

#### Any valid IP address

In dotted decimal format. If the client is defined within a subnet scope, the IP address must be within the subnet range.

**none** Indicates that the matching client will not be serviced

**any** Indicates that any IP address in the subnet pool can be supplied to the client.

**Default Value:** None

**Note:** An **id-type** of *0* and an **id-value** of *0* indicates that the specified IP address should not be distributed by the server.

## DHCP Server Configuration Commands (Talk 6)

### Example:

```
DHCP Server config> add client global
Enter the client name []? ClientA
Enter the client's hardware type (0 - 21) [1]? 0
Enter the client ID (MAC address or string) []? ClientA
Enter the client's IP address (IP address, any, none) []? 9.1.1.1
Client record with name ClientA has been added

DHCP Server config> add client subnet
Enter the subnet name []? subA
Enter the client name []? CliA
Enter the client's hardware type (0 - 21) [1]? 1
Enter the client ID (MAC address or string) []? 400000000010
Enter the client's IP address (IP address, any, none) []? 10.1.1.10
Client record with name CliA has been added
```

**option** *scope [subnet-name] [class-name] [client-name] [vendor-name] code data*  
Defines an option. Options can exist globally, or within a subnet, class, client, or vendor-option scope.

**scope** Specifies the scope in which the option is being added.

#### Valid Values:

- class-global
- class-subnet
- client-global
- client subnet
- global
- subnet
- vendor-option

**Default Value:** None

#### subnet-name

Valid only if the **scope** is *subnet*, *class-subnet*, or *client-subnet*. Specifies the name of the subnet to which the client is being added.

**Valid Values:** Any existing subnet name

**Default Value:** None

#### class-name

Valid only if the **scope** is *class-global* or *class-subnet*. Indicates the name of the class to which the option is being added.

**Valid Values:** An existing class name

**Default Value:** None

#### client-name

Valid only if the **scope** is *client-global* or *client-subnet*. Indicates the name of the client to which the option is being added.

**Valid Values:** Any existing client name

**Default Value:** None

#### vendor-name

Valid only if the **scope** is *vendor-option*. Indicates the name of the vendor to which the option is being added.

**Valid Values:** Any existing vendor name

**Default Value:** None



## DHCP Server Configuration Commands (Talk 6)

**code** Specifies the option code. The DHCP options are defined in RFC 2132. See “DHCP Options” on page 496 for a description of options and their formats.

**Valid Values:** 1 - 255

**Default Value:** 1

**data** Specifies the option data. Option data can be defined in three ways.

- ASCII strings for specific formats defined in RFC 2132.
- Hexadecimal conversion at initialization time. The data should be entered as *hex: 01 aa 04*.
- Character string. The data should be entered as *abcdef*.

**Example:**

```
DHCP Server config> add option global
Enter the option code [1]? 3
Enter the option data []? 9.167.100.1
```

**Example:**

```
DHCP Server config> add option subnet
Enter the subnet name []? subA
Enter the option code [1]? 3
Enter the option data []? 9.167.100.1
```

**Example:**

```
DHCP Server config> add option class-global
Enter the class name []? ClassA
Enter the option code [1]? 3
Enter the option data []? 9.167.100.1
```

**Example:**

```
DHCP Server config> add option client
Enter the client name []? ClientA
Enter the option code [1]? 3
Enter the option data []? 9.167.100.1
```

**Example:**

```
DHCP Server config> add option class-subnet
Enter the subnet name []? subA
Enter the class name []? ClaA
Enter the option code [1]? 3
Enter the option data []? 9.167.100.1
```

**Example:**

```
DHCP Server config> add option client-subnet
Enter the subnet name []? subA
Enter the client name []? CliA
Enter the option code [1]? 3
Enter the option data []? 9.167.100.1
```

**Example:**

```
DHCP Server config> add option vendor-option
Enter the vendor name []? 200
Enter the option code [1]? 85
Enter the option data []? hex:01 AA 04
```

**Example:**

```
DHCP Server config> add option vendor-option
Enter the vendor name []? 200
Enter the option code [1]? 86
Enter the option data []? 9.67.85.4
```

## DHCP Server Configuration Commands (Talk 6)

**subnet** *subnet\_name subnet-address subnet-mask range-start range-end [subnet\_group\_name] [subnet\_group\_priority] [policy-list]*  
Defines a subnet.

### **subnet-name**

Indicates the name of the subnet.

**Valid Values:** Any 10-character ASCII string

**Default Value:** None

### **subnet-address**

Specifies the address of the subnet. The address is specified in dotted decimal format.

**Valid Values:** Any valid IP subnet address

**Default Value:** None

### **subnet-mask**

Specifies the subnet address mask. The subnet address must be within the subnet mask and cannot contain a larger number of bits than the mask.

**Valid Values:** Any valid IP mask in dotted decimal format

**Default Value:** Calculated based upon the subnet address

### **range-start**

Specifies the starting IP address of the IP pool of addresses that this server will administer for this subnet. If *range-start* is not specified, then all the addresses in the subnet are administered by the server.

**Valid Values:** Any valid IP host address within the specified subnet in dotted decimal format

**Default Value:** The first IP address of the subnet

### **range-end**

Specifies the ending IP address of the IP pool of addresses that this server will administer for this subnet.

**Valid Values:** Any valid IP host address within the specified subnet in dotted decimal format

**Default Value:** **range-start** plus 50. If the resulting IP address is no longer within the subnet, then the default is the last IP address in the subnet.

### **subnet-group-name**

Specifies the subnet group name to which this subnet belongs.

**Valid Values:** Any ASCII string up to 64 characters in length

**Default Value:** None

### **subnet-group-priority**

Specifies this subnet's priority within the subnet group. This priority is used to determine the order in which the addresses are assigned within a specific subnet group.

**Valid Values:** 1 - 65535

**Default Value:** 1

## DHCP Server Configuration Commands (Talk 6)

### policy-list

Identifies which policy address list, Balance or Inorder, to which the subnet group will be added. If the subnet group already exists on one list and the other is specified, the subnet group will be moved to the new list.

**Valid Values:** Inorder or Balance

**Default Value:** If this is a new subnet, the default is Inorder. Otherwise, it is the current policy list to which the subnet group belongs.

### Example:

```
DHCP Server config> add subnet
Enter the subnet name []? subA
Enter the IP subnet []? 10.1.1.0
Enter the IP subnet mask [255.255.255.0]?
Enter start of IP address range [10.1.1.1]?
Enter end of IP address range [10.1.1.31]?
Enter the subnet group name []? group1
Enter the subnet group priority (1 - 65535) [1]?
Enter the access policy list (Inorder or Balance) [Inorder]?
Subnet record with name sub1 has been added
Subnet group group1 is being added to the Inorder List
```

### vendor-option *vendor\_name* [*hex\_value*]

Adds a vendor-option. There are two ways to provide vendor-option data:

- Enter hex data when prompted
- Add specific options to the vendor using the **add option vendor** command. See page 518 for option information.

#### *vendor\_name*

Specifies the name of the vendor.

**Valid Values:** An ASCII string up to 40 characters in length

**Default Value:** None

#### *hex-value*

Specifies the hexadecimal ASCII string which represents the hexadecimal value of the data portion of the option.

**Valid Values:** Any valid hexadecimal string in the following format:

*01 aa 04*

**Default Value:** None

### Example:

```
DHCP Server config> add vendor-option
Enter the vendor name []? XA-client
Enter the vendor hex data []? 01 aa 04
Vendor-option record with name XA-client has been added
```

## Change

Use the **change** command to modify the configuration of a class, client, subnet or vendor-option.

### Syntax:

```
change class
       client
```

## DHCP Server Configuration Commands (Talk 6)

subnet

vendor-option

**class** *scope* [*subnet\_name*] *class\_name* *new\_class\_name* [*new\_range\_start*]  
[*new\_range\_end*]

Modifies a class.

**scope** Specifies the scope of the class being modified.

**Valid Values:** global or subnet

**Default Value:** None

### subnet-name

Valid only if the **scope** is *subnet*. Indicates the name of the subnet to which the class belongs.

**Valid Values:** Any existing subnet name.

**Default Value:** None

### class-name

Indicates the name of the class.

**Valid Values:** Name of an existing class

**Default Value:** None

### new-class-name

Indicates the new name of the class.

**Valid Values:** An ASCII string up to 40 characters in length

**Default Value:** Existing class name

### new-range-start

Valid only if the **scope** is *subnet*. Specifies the new starting IP address for the IP address pool to which clients will be assigned.

**Valid Values:** Any IP address within the subnet range

**Default Value:** Existing range-start

### new-range-end

Specifies the new ending IP address for the IP address pool to which clients will be assigned.

**Valid Values:** Any valid IP address within the subnet range, greater than **new-range-end**

**Default Value:** Existing range-end

### Example:

```
DHCP Server config> change class global
Enter the class name []? ClassA
Enter the new class name [ClassA]?
```

### Example:

```
DHCP Server config> change class subnet
Enter the subnet name []? subA
Enter the class name []? ClaA
Enter the new class name [ClaA]?
Enter start of IP address range [10.1.1.1]?
Enter end of IP address range [10.1.1.6]?
```

## DHCP Server Configuration Commands (Talk 6)

**client** *scope [subnet\_name] client\_name new-client\_name new-id-type new-id-value new-address*

Modifies a client

**scope** Specifies the scope of the client being modified.

**Valid Values:** global or subnet

**Default Value:** None

**subnet-name**

Valid only if the **scope** is *subnet*. Indicates the name of the subnet to which the client belongs.

**Valid Values:** Any existing subnet name

**Default Value:** None

**client-name**

Indicates the name of the client.

**Valid Values:** An existing client name

**Default Value:** None

**new-client-name**

Indicates the new name of the client.

**Valid Values:** An ASCII string up to 10 characters in length

**Default Value:** Existing client name

**new-id-type**

Indicates the new hardware type of the client.

**Valid Values:** 0 - 21 See page 517.

**Default Value:** Existing hardware type of the client

**new-id-value**

Specifies the new client identifier.

**Valid Values:** 0 or any valid MAC address (12 hexadecimal digits)

**Default Value:** Existing client id-type

**Note:** An **id-type** of 0 and an **id-value** of 0 indicates that the specified IP address should not be distributed by the server.

**new-address**

Specifies either the new IP address to be supplied to the client or a character string indicating that the client will not be serviced or that the client can be supplied with any address from the IP address pool.

**Valid Values:**

**Any valid IP address**

**none** Indicates that the matching client will not be serviced

**any** Indicates that any IP address in the subnet pool can be supplied to the client.

**Default Value:** None

## DHCP Server Configuration Commands (Talk 6)

**Note:** An **id-type** of *0* and an **id-value** of *0* indicates that the specified IP address should not be distributed by the server.

### Example:

```
DHCP Server config> change client global
Enter the client name []? ClientA
Enter the new client name [ClientA]?
Enter the new client hardware type (0 - 21) [0]?
Enter the new client ID [ClientA]?
Enter the client's new IP address (IP address, any, none) [9.1.1.1]?
Client ClientA has been changed
```

### Example:

```
DHCP Server config> change client subnet
Enter the subnet name []? subA
Enter the client name []? Clia
Enter the new client name [ClientA]?
Enter the new client hardware type (0 - 21) [1]?
Enter the new client ID [400000000010]?
Enter the client's new IP address (IP address, any, none) [10.1.1.10]?
Client Clia has been changed
```

**subnet** *subnet\_name new\_subnet\_name new\_subnet\_address new\_subnet\_mask new-range\_start new-range\_end*

Modifies a subnet.

#### **subnet\_name**

Indicates the name of the specific subnet to be modified.

**Valid Values:** An existing subnet name

**Default Value:** None

#### **new\_subnet\_name**

Indicates the new name of the specified subnet.

**Valid Values:** Any 10-character ASCII string

**Default Value:** Original subnet name

#### **new\_subnet\_addresses**

Specifies the new address of the subnet. The address is specified in dotted decimal notation.

**Valid Values:** Any valid IP subnet address

**Default Value:** Existing subnet address

#### **new\_subnet\_mask**

Specifies the new subnet address mask. The subnet address must be within the subnet mask and cannot contain a larger number of bits than the mask.

**Valid Values:** Any valid IP mask

**Default Value:** Existing subnet mask

#### **new-range-start**

Specifies the new starting IP address of the IP pool of addresses that this server will administer for this subnet. If *range-start* is not specified, then all the addresses in the subnet are administered by the server.

**Valid Values:** Any valid IP address within the subnet range

**Default Value:** Existing pool starting address

## DHCP Server Configuration Commands (Talk 6)

### **new-range-end**

Specifies the new ending IP address of the IP pool of addresses that this server will administer for this subnet.

**Valid Values:** Any valid IP address within the subnet range and larger than the starting pool address

**Default Value:** Existing pool ending address

### **Example:**

```
DHCP Server config> change subnet
Enter the subnet name []? subA
Enter the new subnet name [subA]?
Enter the new IP subnet [10.1.1.0]?
Enter the new IP subnet mask [255.255.0.0]?
Enter new start of IP address range [10.1.1.1]?
Enter new end of IP address range [10.1.1.31]?
Enter the new subnet group name [group11]?
Enter the new subnet group priority [1]?
Enter the new access policy list (Inorder or Balance) [Inorder]?
```

**vendor-option** *vendor\_name new\_vendor\_name [new\_hex\_value]*

Modifies a vendor-option.

### **vendor\_name**

Specifies the new name of the vendor option.

**Valid Values:** An existing vendor name

**Default Value:** None

### **new\_vendor\_name**

Specifies the new name of the vendor option.

**Valid Values:** An ASCII string up to 40 characters in length

**Default Value:** Existing vendor option name

### **new\_hex\_value**

Specifies the new hexadecimal ASCII string which represents the hexadecimal value of the data portion of the option. A hex value cannot be added if specific options have been added to this vendor option.

**Valid Values:** Any valid hexadecimal string

**Default Value:** Existing hexadecimal string

### **Example:**

```
DHCP Server config> change vendor-option
Enter the vendor name []? XA-clients
Enter the new vendor name [XA-clients]?
Enter the new vendor data [01 aa 04]?
```

## Delete

Use the **delete** command to delete a class, client, option, subnet, subnet-group, or vendor-option.

### **Syntax:**

```
delete class
client
option
```

## DHCP Server Configuration Commands (Talk 6)

subnet

subnet-group

vendor-option

**class** *scope [subnet\_name] class\_name*

Deletes a class and all options defined under its scope.

**scope** Specifies the scope in which the class is being deleted.

**Valid Values:** global or subnet

**Default Value:** None

**subnet-name**

Only valid if the **scope** is *subnet*. Specifies the name of the subnet that the class is being deleted from.

**Valid Values:** Any existing subnet name

**Default Value:** None

**class-name**

Indicates the name of the class to be deleted.

**Valid Values:** An existing class name

**Default Value:** None

**Example:**

```
DHCP Server config> delete class global
Enter the class name []? ClassA
```

**Example:**

```
DHCP Server config> delete class subnet
Enter the subnet name []? subA
Enter the class name []? ClAa
```

**client** *scope [subnet\_name ] client\_name*

Deletes a client and all options defined under its scope.

**scope** Specifies the scope in which the client is being deleted.

**Valid Values:** global or subnet

**Default Value:** None

**subnet\_name**

Only valid if the **scope** is *subnet*. Specifies the name of the subnet that the client is being deleted from.

**Valid Values:** An existing subnet name

**Default Value:** None

**client\_name**

Indicates the name of the client to be deleted.

**Valid Values:** An existing client name

**Default Value:** None

**Example:**

```
DHCP Server config> delete client global
Enter the client name []? ClientA
```

**Example:**



## DHCP Server Configuration Commands (Talk 6)

```
DHCP Server config> delete client subnet
Enter the subnet name []? subA
Enter the client name []? ClIA
```

**option** *scope [subnet\_name] [class\_name] [client\_name] [vendor\_name] code*  
Deletes an option within the specified scope.

**scope** Specifies the scope in which the option is being deleted.

**Valid Values:**

- class-global
- class-subnet
- client-global
- client subnet
- global
- subnet
- vendor-option

**Default Value:** None

**subnet-name**

Valid only if the **scope** is *subnet*, *class-subnet*, or *client-subnet*. Specifies the name of the subnet from which the client is being deleted.

**Valid Values:** Any existing subnet name

**Default Value:** None

**class-name**

Valid only if the **scope** is *class-global* or *class-subnet*. Indicates the name of the class from which the option is being deleted.

**Valid Values:** An existing class name

**Default Value:** None

**client-name**

Valid only if the **scope** is *client-global* or *client-subnet*. Indicates the name of the client from which the option is being deleted.

**Valid Values:** Any existing client name

**Default Value:** None

**vendor-name**

Valid only if the **scope** is *vendor-option*. Indicates the name of the vendor from which the option is being deleted.

**Valid Values:** Any existing vendor name

**Default Value:** None

**code** Specifies the option code. The DHCP options are defined in RFC 2132. See “DHCP Options” on page 496 for a description of options and their formats.

**Valid Values:** 1 - 255

**Default Value:** 1

**Example:**

## DHCP Server Configuration Commands (Talk 6)

```
DHCP Server config> delete option global
Enter the option code [1]? 3
```

**Example:**

```
DHCP Server config> delete option subnet
Enter the subnet name []? subA
Enter the option code [1]? 3
```

**Example:**

```
DHCP Server config> delete option class-global
Enter the class name []? ClassA
Enter the option code [1]? 3
```

**Example:**

```
DHCP Server config> delete option client
Enter the client name []? ClientA
Enter the option code [1]? 3
```

**Example:**

```
DHCP Server config> delete option class-subnet
Enter the subnet name []? subA
Enter the class name []? ClaA
Enter the option code [1]? 3
```

**Example:**

```
DHCP Server config> delete option client-subnet
Enter the subnet name []? subA
Enter the client name []? CliA
Enter the option code [1]? 3
```

**Example:**

```
DHCP Server config> delete option vendor-option
Enter the vendor name []? XI-clients
Enter the option code [1]? 85
```

**Example:**

```
DHCP Server config> delete option vendor-option
Enter the vendor name []? 200
Enter the option code [1]? 86
```

### **subnet** *subnet\_name*

Deletes a subnet and all classes, clients, and options that are defined under its scope.

#### **subnet\_name**

Specifies the name of the subnet being deleted.

**Valid Values:** Any existing subnet name

**Default Value:** None

**Example:**

```
DHCP Server config> delete subnet
Enter the subnet name []? subA
You are about to delete a subnet subA
and all the associated class, client, and option records associated with it
Are you sure you want to continue? [No]:
```

### **subnet-group** *subnet\_group\_name*

Deletes all subnets associated with a particular subnet group and all the classes, clients and options defined under the subnet scopes.

#### **subnet\_group\_name**

Specifies the name that identifies the subnet group.

## DHCP Server Configuration Commands (Talk 6)

**Valid Values:** An existing subnet group name

**Default Value:** None

**Example:**

```
DHCP Server config> delete subnet-group
Enter the subnet group name []? group2
You are about to delete a all subnets in group group2
and all the associated class, client, and option records associated with them
Are you sure you want to continue? [No]:
```

**vendor-option** *vendor\_name*

Deletes a vendor-option and any options defined under its scope.

*vendor\_name*

Specifies the name of the vendor.

**Valid Values:** An ASCII string up to 40 characters in length

**Default Value:** None

**Example:**

```
DHCP Server config> delete vendor-option
Enter the vendor name []? XA-clients
```

## Disable

Use the **disable** command to disable DHCP server globally.

**Syntax:**

**disable** dhcp-server

**Example:**

```
DHCP Server config> disable dhcp-server
```

## Enable

Use the **enable** command to enable DHCP server globally.

**Syntax:**

**enable** dhcp-server

**Example:**

```
DHCP Server config> enable dhcp-server
```

## List

Use the **list** command to list configuration information about a class, client, global parameters, subnets or vendor-options and any associated options.

**Syntax:**

**list** class  
client  
global

## DHCP Server Configuration Commands (Talk 6)

option  
subnet  
vendor-option

```
class all
    global class-name
    subnet class-name
```

Lists either a summary of all the configured classes or the details of a specific class.

### class-name

Indicates the name of the class to be displayed.

**Valid Values:** An existing class name

**Default Value:** None

### Example:

```
DHCP Server config> list class all
```

```
class          attached
name          to subnet
-----
ClassA
ClaA          subA
```

### Example:

```
DHCP Server config> list class global
Enter the class name []? ClassA
```

```
class
name
-----
ClassA
Bootstrap Server: 100.100.100.100
Canonical: Yes
Support Unlisted Clients: Yes
Number of Options: 1
option  option
code    data
-----
1       255.255.0.0
```

### Example:

```
DHCP Server config> list class subnet
Enter the subnet name []? subA
Enter the class name []? ClaA
```

```
class
name
-----
ClaA
starting IP address: 10.1.1.3
ending IP address: 10.1.1.5
Bootstrap Server: 100.100.100.100
Canonical: Yes
Support Unlisted Clients: DHCP

Number of Options: 1
```

## DHCP Server Configuration Commands (Talk 6)

```
option   option
code     data
-----
6        9.67.100.1
```

**client** all  
global *client-name*  
subnet *client-name*

Lists either a summary of all the configured clients or the details of a specific client.

### client-name

Indicates the name of the client to be displayed.

**Valid Values:** An existing client name

**Default Value:** None

### Example:

```
DHCP Server config> list client all
client  client  client      attached  IP
name    type    identifier  to subnet address
-----
ClientA 0      ClientA                    9.1.1.1
CliA    1      400000000010  subA     10.1.1.10
```

### Example:

```
DHCP Server config> list client global
Enter the client name []? ClientA
```

### Example:

```
DHCP Server config> list client subnet
Enter the subnet name []? subA
Enter the client name []? CliA

client client  client      IP
name    type    identifier  address
-----
CliA    1      400000000010 10.1.1.10
Bootstrap Server: 200.200.200.200
Canonical: Yes

Number of Options: 1
option  option
code    data
-----
6       9.67.100.1
```

## global

Lists global parameters.

### Example:

```
DHCP Server config> list global

DHCP server Global Parameters
=====
DHCP server enabled: Yes
```

## DHCP Server Configuration Commands (Talk 6)

```
Balance: group2
Inorder: group1
Canonical: No
Lease Expire Interval: 1 minute(s)
Lease Time Default: 1 day(s)
Support BOOTP Clients: No
Bootstrap Server: Not configured
Support Unlisted Clients: Yes
Ping Time: 1 second(s)
Used IP Address Expire Interval: 15 minute(s)
```

**option** *scope* [*subnet-name*] [*class-name*] [*client-name*] [*vendor-name*] *code*

**scope** Specifies the scope in which the option is being listed.

**Valid Values:**

- class-global
- class-subnet
- client-global
- client subnet
- global
- subnet
- vendor-option

**Default Value:** None

**subnet-name**

Valid only if the **scope** is *subnet*, *class-subnet*, or *client-subnet*. Specifies the name of the subnet to which the option being listed belongs.

**Valid Values:** Any existing subnet name

**Default Value:** None

**class-name**

Valid only if the **scope** is *class-global* or *class-subnet*. Indicates the name of the class to which the option being listed belongs.

**Valid Values:** An existing class name

**Default Value:** None

**client-name**

Valid only if the **scope** is *client-global* or *client-subnet*. Indicates the name of the client to which the option being listed belongs.

**Valid Values:** Any existing client name

**Default Value:** None

**vendor-name**

Valid only if the **scope** is *vendor-option*. Indicates the name of the vendor to which the option being listed belongs.

**Valid Values:** Any existing vendor name

**Default Value:** None

## DHCP Server Configuration Commands (Talk 6)

**code** Specifies the option code. The DHCP options are defined in RFC 2132. See “DHCP Options” on page 496 for a description of options and their formats.

**Valid Values:** 1 - 255

**Default Value:** 1

**Example:**

```
DHCP Server config> list option global
```

```
option  option
code    data
-----
3       9.67.100.1
```

**Example:**

```
DHCP Server config> list option class-global
```

```
Enter the class name []? ClassA
option  option
code    data
-----
3       9.67.100.1
```

**Example:**

```
DHCP Server config> list option class-subnet
```

```
Enter the subnet name []? subA
Enter the class name []? claA
option  option
code    data
-----
3       9.67.100.1
```

**Example:**

```
DHCP Server config> list option client-global
```

```
Enter the client name []? ClientA
option  option
code    data
-----
3       9.67.100.1
```

**Example:**

```
DHCP Server config> list option client-subnet
```

```
Enter the subnet name []? subA
Enter the client name []? cliA
option  option
code    data
-----
3       9.67.100.1
```

**Example:**

```
DHCP Server config> list option subnet
```

## DHCP Server Configuration Commands (Talk 6)

Enter the subnet name []? **subA**

```
option  option
code   data
-----
6      9.67.100.1
```

### Example:

```
DHCP Server config> list option vendor-option
Enter the vendor name []? XI-clients
```

```
option  option
code   data
-----
85     hex:01 aa 04
86     9.67.85.4
```

### subnet

all

detailed *subnet-name*

Lists either a summary of all the configured subnets or the details of a specific subnet.

### subnet-name

Indicates the name of the subnet to be displayed.

**Valid Values:** An existing subnet name

**Default Value:** None

### Example:

```
DHCP Server config> list subnet all
```

```
name    address    mask          IP Addr    IP Addr
-----
subA    10.1.1.0    255.255.0.0  10.1.1.1  10.1.1.31
subB    11.1.1.0    255.255.0.0  11.1.1.1  11.1.1.31
```

### Example:

```
DHCP Server config> list subnet detailed
Enter the subnet name []? subA
```

```
subnet  subnet  subnet  starting  ending
name    address  mask    IP Addr   IP Addr
-----
subA    10.1.1.0 255.255.0.0 10.1.1.1 10.1.1.31
Subnet Group: group1/1
```

Number of Classes: 1

```
class
name
```

```
-----
ClaA
starting IP address: 10.1.1.1
ending   IP address: 10.1.1.6
Bootstrap Server: 100.100.100.100
Canonical: Yes
Support Unlisted Clients: DHCP
```



## DHCP Server Configuration Commands (Talk 6)

```
Number of Options: 1
option  option
code   data
-----
6      9.67.100.1

Number of Clients: 1
client  client  client      IP
name    type    identifier  address
-----
Clia    1        400000000010  10.1.1.10
Bootstrap Server: 200.200.200.200
Canonical: Yes

Number of Options: 1
option option
code  data
-----
6     9.67.100.1

Number of Options: 1
option option
code  data
-----
1     255.255.255.0
```

```
vendor-option          all
                        detailed vendor-name
```

Lists either a summary of all the configured vendors or the details of a specific vendor-option.

### vendor-name

Indicates the name of the vendor-option to be displayed.

**Valid Values:** An existing vendor-name

**Default Value:** None

### Example:

```
DHCP Server config> list vendor-option all
```

```
vendor      hex
name        data
-----
XA-clients  01 AA 04
XI-clients
```

```
DHCP Server config> list vendor-option detailed
```

```
Enter the vendor name []? XI-clients
vendor      hex
name        data
-----
XI-clients

Number of Options: 2
option  option
code   data
-----
85     hex:01 AA 04
86     9.67.85.4
```

## DHCP Server Configuration Commands (Talk 6)

### Set

Use the **set** command to specify values for global parameters and to add subnet groups to the Balance and Inorder lists.

#### Syntax:

**set**  
\_ balance  
bootstrapserver  
canonical  
inorder  
lease-expire-interval  
lease-time-default  
ping-time  
support-bootp  
support-unlisted-clients  
used-ip-address-expire-interval

#### **balance** *subnet\_group\_name*

Adds or moves a subnet group to the Balance list. Addresses will be assigned in a round robin fashion from all the subnets associated with the group(s) defined within a subnet group, according to their priority.

#### **subnet\_group\_name**

Specifies the name of the subnet group to which this subnet belongs.

**Valid Values:** An existing subnet group name

**Default Value:** None

#### **Example:**

```
DHCP Server config> set balance  
Enter the subnet group name []? group1
```

#### **bootstrapserver** *scope [subnet-name] [class-name] [client-name] address*

Specifies whether or not the DHCP server specifies a bootstrap server for clients. If you want the DHCP server to specify a bootstrap server, you should define the IP address of the server. This parameter can be specified within the global, subnet, class or client scope.

**scope** Specifies the scope of the bootstrapserver parameter.

#### **Valid Values:**

- class-global
- class-subnet
- client-global
- client-subnet
- global
- subnet

**Default Value:** None

## DHCP Server Configuration Commands (Talk 6)

### subnet-name

Valid if the scope is *subnet*, *class-subnet* or *client-subnet*. Indicates the name of the subnet for which the bootstrap server is being specified.

**Valid Values:** An existing subnet name

**Default Value:** None

### class-name

Valid if the scope is *class-global* or *class-subnet*. Indicates the name of the class for which the bootstrap server is being specified.

**Valid Values:** An existing class name

**Default Value:** None

### client-name

Valid if the scope is *client-global* or *client-subnet*. Indicates the name of the client for which the bootstrap server is being specified.

**Valid Values:** An existing client name

**Default Value:** None

### IP address of the server

Specifies the IP address of the bootstrap server.

**Valid Values:** Any valid IP address in dotted decimal format

**Default Value:** None

#### Example:

```
DHCP Server config> set bootstrap-server class-global
Enter the class name []? ClassA
Enter the IP address of the server []? 100.100.100.100
```

#### Example:

```
DHCP Server config> set bootstrap-server class-subnet
Enter the subnet name []? subA
Enter the class name []? ClassA
Enter the IP address of the server []? 100.100.100.100
```

#### Example:

```
DHCP Server config> set bootstrap-server client-global
Enter the client name []? ClientA
Enter the IP address of the server []? 100.100.100.100
```

#### Example:

```
DHCP Server config> set bootstrap-server client-subnet
Enter the subnet name []? subA
Enter the client name []? ClientA
Enter the IP address of the server []? 100.100.100.100
```

#### Example:

```
DHCP Server config> set bootstrap-server global
Enter the IP address of the server []? 100.100.100.100
```

#### Example:

```
DHCP Server config> set bootstrap-server subnet
Enter the subnet name []? subA
Enter the IP address of the server []? 100.100.100.100
```

## DHCP Server Configuration Commands (Talk 6)

**canonical** *scope* [*subnet-name*] [*class-name*] [*client-name*] *value*

Specifies whether the DHCP server will transform MAC addresses to canonical format.

MAC addresses for Ethernet/802.3 clients are stored in the canonical (byte starts with least significant bit) format. MAC addresses for Token-Ring clients are stored in the non-canonical (byte starts with most significant bit) format. This parameter should be used when the DHCP server is on one media type (Token-Ring or Ethernet/802.3), the client is on the other media type and there is a translational bridge between the two. When this parameter is set to *yes*, the DHCP server will cause the client's MAC address to be flipped from either canonical to non-canonical or non-canonical to canonical. Since the DHCP server does not know which format the MAC address is originally in, setting this parameter to *yes* will just flip the address. Canonical can be set within the global, subnet, class or client scope.

**scope** Specifies the scope of the `bootstrapservers` parameter.

**Valid Values:**

- class-global
- class-subnet
- client-global
- client-subnet
- global
- subnet

**Default Value:** None

**subnet-name**

Valid if the scope is *subnet*, *class-subnet* or *client-subnet*. Indicates the name of the subnet for which canonical is being specified.

**Valid Values:** An existing subnet name

**Default Value:** None

**class-name**

Valid if the scope is *class-global* or *class-subnet*. Indicates the name of the class for which canonical is being specified.

**Valid Values:** An existing class name

**Default Value:** None

**client-name**

Valid if the scope is *client-global* or *client-subnet*. Indicates the name of the client for which canonical is being specified.

**Valid Values:** An existing client name

**Default Value:** None

**value** Specifies whether MAC addresses are to be transformed to canonical format

**Valid Values:** yes, no

**Default Value:** no, if the **scope** is *global*. Otherwise, the default value is determined by the scope hierarchy. See "Concepts and Terminology" on page 493 for an explanation of scope.

## DHCP Server Configuration Commands (Talk 6)

### Example:

```
DHCP Server config> set canonical class-global
Enter the class name []? ClassA
Would you like MAC addresses to be transformed to canonical format? [No] yes
```

### Example:

```
DHCP Server config> set canonical class-subnet
Enter the subnet name []? subA
Enter the class name []? ClassA
Would you like MAC addresses to be transformed to canonical format? [No] yes
```

### Example:

```
DHCP Server config> set canonical client-global
Enter the client name []? ClientA
Would you like MAC addresses to be transformed to canonical format? [No] yes
```

### Example:

```
DHCP Server config> set canonical client-subnet
Enter the subnet name []? subA
Enter the client name []? ClientA
Would you like MAC addresses to be transformed to canonical format? [No] yes
```

### Example:

```
DHCP Server config> set canonical global
Would you like MAC addresses to be transformed to canonical format? [No] yes
```

### Example:

```
DHCP Server config> set canonical subnet
Enter the subnet name []? subA
Would you like MAC addresses to be transformed to canonical format? [No] yes
```

### **inorder** *label-list*

Adds or moves a subnet group to the Inorder list. Addresses will be assigned from the subnets in a subnet group in order of the priority assigned to that subnet.

#### **subnet\_group\_name**

Specifies the subnet group to which this subnet belongs.

**Valid Values:** An existing subnet group name

**Default Value:** None

### Example:

```
DHCP Server config> set inorder
Enter the subnet group name []? g2
```

### **lease-expire-interval** *time length*

Specifies the interval at which the lease condition of all the addresses in the address pool is examined to determine which leases have expired. The lease expire interval can only be set at the global level.

**time** Specifies the unit of time measurement.

**Valid Values:** seconds, minutes, hours

**Default Value:** None

**length** Specifies how long the interval will be.

**Valid Values:** 15 seconds - 12 hours

**Default Value:**

- 15 (if the time unit is seconds)

## DHCP Server Configuration Commands (Talk 6)

- 1 (if the time unit is minutes)
- 1 (if the time unit is hours)

**Example:**

```
DHCP Server config> set lease-expire-interval seconds
How long is the interval in seconds (max:59) [15]? 59
```

**Example:**

```
DHCP Server config> set lease-expire-interval minutes
How long is the interval in minutes (max:59) [1]? 45
```

**Example:**

```
DHCP Server config> set lease-expire-interval hours
How long is the interval in hours (max:12) [1]? 2
```

### **lease-time-default** *time length*

Specifies the default lease duration for the leases issued by the DHCP Server. An interval of infinity means that leases will never expire. The lease time default can only be set at the global level.

**time** Specifies the unit of time measurement.

**Valid Values:** minutes, hours, days, weeks, months, years, infinity

**Default Value:** None

**length** Specifies how long the interval will be.

**Valid Values:** 3 minutes - infinity

**Default Value:**

- 3 (if the time unit is minutes)
- 1 (if the time unit is hours)
- 1 (if the time unit is days)
- 1 (if the time unit is months)
- 1 (if the time unit is years)

**Example:**

```
DHCP Server config> set lease-time-default minutes
How long is the interval in minutes (max:59) [3]? 2
```

**Example:**

```
DHCP Server config> set lease-time-default hours
How long is the interval in hours (max:23) [1]? 12
```

**Example:**

```
DHCP Server config> set lease-time-default days
How long is the interval in days (max:6) [1]? 2
```

**Example:**

```
DHCP Server config> set lease-time-default weeks
How long is the interval in weeks (max:3) [1]? 1
```

**Example:**

```
DHCP Server config> set lease-time-default months
How long is the interval in months (max:11) [1]? 3
```

**Example:**

```
DHCP Server config> set lease-time-default years
How long is the interval in years (max:10) [1]? 3
```

## DHCP Server Configuration Commands (Talk 6)

### Example:

```
DHCP Server config> set lease-time-default infinity
```

### **ping-time** *time length*

Before assigning an IP address, the DHCP server tests to be sure the IP address is not in use. This value specifies how long the DHCP server will wait for a ping response before marking the address available. A value of 0 disables pings, resulting in the DHCP server not testing an address before assigning it.

**time** Specifies the unit of time measurement.

**Valid Values:** seconds

**Default Value:** None

**length** Specifies how long the interval will be.

**Valid Values:** 0 - 5 seconds

**Default Value:** 1

### Example:

```
DHCP Server config> set ping-time seconds
How long is the interval in seconds (max:5) [1]? 3
```

### **support-bootp** *value*

Specifies whether the server will respond to requests from BOOTP clients. If the DHCP server was previously configured to support BOOTP clients and has been reconfigured to not support BOOTP clients, the address binding for any BOOTP clients that was established before the reconfiguration will be maintained until the BOOTP client sends another request (when it is restarting). At that time, the server will not respond, and the binding will be removed. This parameter can only be set at the global level.

**Valid Values:** yes or no

**Default Value:** no

### Example:

```
DHCP Server config> set support-bootp
Would you like the server to support BOOTP clients? [No] yes
```

### **support-unlisted-clients** *scope [subnet-name] [class-name] value*

Specifies whether the server will respond to requests from DHCP clients other than those whose client IDs are specifically listed in this configuration. This parameter has several possible values:

**scope** Specifies the scope of the **support-unlisted-clients** parameter.

**Valid Values:**

- class-global
- class-subnet
- global
- subnet

**Default Value:** None

## DHCP Server Configuration Commands (Talk 6)

### subnet-name

Valid is the scope is *subnet*, *class-subnet*, or *client-subnet*. Indicates the name of the subnet for which this parameter is being specified.

**Valid Values:** An existing subnet name

**Default Value:** None

### class-name

Valid is the scope is *class-global*, or *class-subnet*. Indicates the name of the class for which this parameter is being specified.

**Valid Values:** An existing class name

**Default Value:** None

### value

**yes** DHCP server should respond to any client no matter the type or if its configured.

**no** DHCP server will respond only to requests from DHCP clients that are configured.

**bootp** DHCP server will support unlisted BOOTP clients but not unlisted DHCP clients

**dhcp** DHCP server will respond to unlisted DHCP clients but not unlisted BOOTP clients.

**Valid Values:** yes, no, bootp, dhcp

**Default Value:** yes, if the **scope** is *global*. Otherwise, the default value is determined by the scope hierarchy. See “Concepts and Terminology” on page 493 for an explanation of scope.

### Example:

```
DHCP Server config> set support-unlisted-clients class-global yes
Enter the class name []? ClassA
```

### Example:

```
DHCP Server config> set support-unlisted-clients class-subnet no
Enter the subnet name []? subA
Enter the class name []? ClassA
```

### Example:

```
DHCP Server config> set support-unlisted-clients global bootp
```

### Example:

```
DHCP Server config> set support-unlisted-clients subnet dhcp
Enter the subnet name []? subA
```

### used-ip-address-expire-interval *time length*

Specifies the interval the server will hold an in-use IP address before making the address available for assignment. Before the server allocates an IP address, it pings the address to make sure it is not already in use on the network. The server then marks the in-use address reserved. This parameter specifies how long an in-use address is kept as reserved before making the address available for assignment. This parameter can only be set at the global level.

**time** Specifies the unit of time measurement.



## DHCP Server Configuration Commands (Talk 6)

**Valid Values:** seconds, minutes, hours, days, weeks, months, years, infinity

**Default Value:** None

**length** Specifies how long the interval will be.

**Valid Values:** 30 seconds - infinity

**Default Value:**

- 30 (if the time unit is seconds)
- 15 (if the time unit is minutes)
- 1 (if the time unit is hours)
- 1 (if the time unit is days)
- 1 (if the time unit is months)
- 1 (if the time unit is years)

**Example:**

```
DHCP Server config> set used-ip-address-expire-interval seconds
How long is the interval in seconds (max:59) [30]? 2
```

**Example:**

```
DHCP Server config> set used-ip-address-expire-interval minutes
How long is the interval in minutes (max:59) [15]? 2
```

**Example:**

```
DHCP Server config> set used-ip-address-expire-interval hours
How long is the interval in hours (max:23) [1]? 5
```

**Example:**

```
DHCP Server config> set used-ip-address-expire-interval days
How long is the interval in days (max:6) [1]? 2
```

**Example:**

```
DHCP Server config> set used-ip-address-expire-interval weeks
How long is the interval in weeks (max:3) [1]? 1
```

**Example:**

```
DHCP Server config> set used-ip-address-expire-interval months
How long is the interval in months (max:11) [1]? 3
```

**Example:**

```
DHCP Server config> set used-ip-address-expire-interval years
How long is the interval in years (max:10) [1]? 3
```

**Example:**

```
DHCP Server config> set used-ip-address-expire-interval infinity
```

---

## Accessing the DHCP Server Monitoring Environment

Use the following procedure to access the DHCP server *monitoring* process.

1. At the OPCON prompt, enter **talk 5**. For example:

```
* talk 5
Config>
```

## DHCP Server Configuration Commands (Talk 6)

After you enter the **talk 5** command, the CONFIG prompt (+) displays on the terminal. If the prompt does not appear when you first enter configuration, press **Return** again.

2. At the + prompt, enter the **feature dhcp-server** command to get to the DHCP Server> prompt.

---

## DHCP Server Monitoring Commands

Table 61. DHCP Server Monitoring Command Summary

Command	Function
? (Help)	Displays all the commands available for this command level or lists the options for specific commands (if available). See “Getting Help” on page xxxii.
Disable	Dynamically disables the DHCP server.
Enable	Dynamically enables the DHCP server.
List	Displays parameters for classes, clients, globals, subnets, and vendor-options.
Reset	Dynamically resets the DHCP Server configuration.
Request	
Exit	Returns you to the previous command level. See “Exiting a Lower Level Environment” on page xxxii.

### Disable

Use the **disable** command to dynamically disable the DHCP server.

**Syntax:**

**disable** dhcp

### Enable

Use the **enable** command to dynamically enable the DHCP server.

**Syntax:**

**enable** dhcp

### List

Use the **list** command to list configuration information about a class, client, global parameters, subnets or vendor-option and any associated options. See “List” on page 529 for examples of the **list** command.

**Syntax:**

**list** class  
client  
global  
option  
subnet  
vendor-option

## Reset

Use the **reset** command to dynamically reset the DHCP Server configuration.

### Syntax:

**reset** dhcp

### Example:

```
DHCP Server> reset dhcp
You are about to reset the DHCP Server.
Are you sure you want to continue? [No]: y
DHCP Server has been reset
DHCP Server>
```

## Request

Use the **request** command to display admin information.

### Syntax:

**request** clientid  
delete  
ipquery  
poolquery  
stats  
status

### **clientid** *client\_id*

Displays information for a client.

### **client\_id**

Indicates the identifier of the client.

**Valid Values:** An existing client id

**Default Value:** None

### Example:

```
DHCP Server> request clientid
Enter the client name []? 0020351FB371

Client id: 1-0x0020351FB371
Status: BOUND
Address last assigned: 192.9.200.10
Most recent lease time: 16:41:25 December 3, 1998
Proxy flag: FALSE
Hostname: Win-XY-1
Domain name: city.net
```

### **delete** *address*

Deletes a lease for a specific client's IP address.

### **address**

Indicates the IP address of the client to be deleted.

**Valid Values:** Any valid IP address of an existing client

**Default Value:** None

### Example:

## DHCP Server Monitoring Commands (Talk 5)

```
DHCP Server> request delete
Enter the client's IP address []? 194.3.200.10
```

### **ipquery** *address*

Displays information for an IP address.

#### **Example:**

```
DHCP Server>req ipquery 192.168.8.3
IP address:      192.168.8.3
Status:          RECLAIMED
Lease time:      86400 seconds
Start time:      Not Leased
Last time leased: 04:16:33 March 9, 1999
DHCP Server>
```

### **poolquery** *address*

Displays information for a pool of IP addresses.

#### **address**

Indicates an IP address in the pool to be displayed.

**Valid Values:** Any valid IP address in the pool to be displayed

**Default Value:** None

#### **Example:**

```
DHCP Server> request poolquery
Enter the client's IP address []? 194.3.200.10
IP address:      194.3.200.10
Status:          LEASED
Lease time:      86400 seconds
Start time:      16:41:25 December 3, 1998
Last time leased: 16:41:25 December 3, 1998
Client id:       1-0x0020351FB371
Hostname:        Win-XY-1
Domain name:     city.net
IP address:      194.3.200.11
Status:          STOCKED
IP address:      194.3.200.12
Status:          STOCKED
```

**stats** Displays statistics information about the pool of addresses administered by the server. The statistics include: discover packets processed, discover packets with no response, offers made, leases granted, negative acknowledgments (NAKs), informs processed, including informs plus acknowledgments (ACKs), renewals, releases, BOOTP clients processed, proxyARec updated attempted, unsupported packets. Syntax: request stats

#### **Example:**

```
DHCP Server> request stats
Number of DISCOVER requests received:      8
Number of OFFER responses sent:            4
Number of ACK responses sent:              3
Number of NACK responses sent:             0
Number of RELEASE requests received:       0
Number of DECLINE packets received:        0
Number of INFORM requests received:        0
Number of BOOTP requests received:         0
Number of requests received via proxy:     0
Number of UNSUPPORTED requests received:   0
Total number of request/responses:         15
Number of lease expirations:               0
```

**status** Displays information about the address pools.

#### **Example:**

## DHCP Server Monitoring Commands (Talk 5)

DHCP Server> **request status**

```
IP address:      194.3.200.10
Status:          LEASED
Lease time:      86400 seconds
Start time:      16:41:25 December 3, 1998
Last time leased: 16:41:25 December 3, 1998
Client id:       1-0x0020351FB371
Hostname:        Win-XY-1
Domain name:     city.net

IP address:      194.3.200.11
Status:          STOCKED

IP address:      194.3.200.12
Status:          STOCKED

IP address:      194.3.200.10
Status:          STOCKED
```

---

### DHCP Dynamic Reconfiguration Support

This section describes dynamic reconfiguration (DR) as it affects Talk 6 and Talk 5 commands.

#### CONFIG (Talk 6) Delete Interface

Dynamic Host Configuration Protocol (DHCP) does not support the CONFIG (Talk 6) **delete interface** command.

#### GWCON (Talk 5) Activate Interface

The GWCON (Talk 5) **activate interface** command is not applicable for Dynamic Host Configuration Protocol (DHCP). DHCP configuration is not based upon specific interfaces.

#### GWCON (Talk 5) Reset Interface

The GWCON (Talk 5) **reset interface** command is not applicable for Dynamic Host Configuration Protocol (DHCP). DHCP configuration is not based upon specific interfaces.

#### GWCON (Talk 5) Component Reset Commands

Dynamic Host Configuration Protocol (DHCP) supports the following Dynamic Host Configuration Protocol (DHCP)-specific GWCON (Talk 5) **reset** commands:

##### GWCON, Feature DHCP, Reset DHCP Command

**Description:**

Reset the DHCP Server and initialize with the changed configuration.

**Network Effect:**

If the changed configuration supports the same clients, they will be offered a new lease at renewal time. If the changed configuration does not support the same clients, their lease will expire.

**Limitations:**

- On routers without a hard file or flash storage card, after a reset, the DHCP clients will continue to operate with their leases, but the DHCP Server will no longer have knowledge of them.

## DHCP Server Monitoring Commands (Talk 5)

- On routers without a hard file or flash storage card, IP addresses leased previously by the DHCP Server will be marked “USED” in the “GWCON, feature DHCP, request status” command upon an attempt to lease that address again.

The following table summarizes the Dynamic Host Configuration Protocol (DHCP) configuration changes that are activated when the **GWCON, feature DHCP, reset dhcp** command is invoked:

Commands whose changes are activated by the GWCON, feature DHCP, reset dhcp command
CONFIG, feature DHCP, add class
CONFIG, feature DHCP, add client
CONFIG, feature DHCP, add option
CONFIG, feature DHCP, add subnet
CONFIG, feature DHCP, add vendor-option
CONFIG, feature DHCP, change class
CONFIG, feature DHCP, change client
CONFIG, feature DHCP, change subnet
CONFIG, feature DHCP, change vendor-option
CONFIG, feature DHCP, delete class
CONFIG, feature DHCP, delete client
CONFIG, feature DHCP, delete option
CONFIG, feature DHCP, delete subnet
CONFIG, feature DHCP, delete subnet-group
CONFIG, feature DHCP, delete vendor-option
CONFIG, feature DHCP, disable dhcp-server
CONFIG, feature DHCP, enable dhcp-server
CONFIG, feature DHCP, set balance
CONFIG, feature DHCP, set bootstrapservers
CONFIG, feature DHCP, set canonical
CONFIG, feature DHCP, set inorder
CONFIG, feature DHCP, set lease-expire-interval
CONFIG, feature DHCP, set lease-time-default
CONFIG, feature DHCP, set ping-time
CONFIG, feature DHCP, set support-bootp
CONFIG, feature DHCP, set support-unlisted-clients
CONFIG, feature DHCP, set used-ip-address-expire-interval

## GWCON (Talk 5) Temporary Change Commands

Dynamic Host Configuration Protocol (DHCP) supports the following GWCON commands that temporarily change the operational state of the device. These changes are lost whenever the device is reloaded, restarted, or you execute any dynamically reconfigurable command.

Commands
----------

## DHCP Server Monitoring Commands (Talk 5)

GWCON, feature DHCP, disable dhcp
-----------------------------------

GWCON, feature DHCP, enable dhcp
----------------------------------

### Non-Dynamically Reconfigurable Commands

All Dynamic Host Configuration Protocol (DHCP) configuration parameters can be changed dynamically.





---

## Chapter 34. Using Thin Server Feature

This chapter describes how to use the Thin Server Feature (TSF) in the IBM 2212.

---

### Network Station Overview

A Network Station is similar to a personal computer (PC), having a keyboard, display, and a mouse. The main difference between a Network Station and a PC is that the Network Station files reside on a network server rather than on a hard drive inside of your machine. The Network Station presents you a graphical user interface (GUI), which provides access to many resources, including emulators, remote X applications, Web browsers, applications, and printers.

The Network Station communicates using TCP/IP over a token-ring or Ethernet connection to the server. The Network Station power-on process is:

- A non-volatile random access memory resident boot monitor program is started and power on self tests are executed.
- The Network Station contacts a BootP or DHCP server which provides the Network Station with information such as its IP address, its server address(es), and the path and name of boot file. Alternatively, the Network Station may retrieve this information from values that are stored in its non-volatile random access memory.
- The Network Station uses Trivial File Transfer Protocol (TFTP), Remote File System/400 (RFS/400), or Network File System (NFS) to download the base code, such as the operating system, hardware configuration files, and application programs, from the base code server.
- The Network Station downloads the terminal-based configuration information, such as configuration for a printer that is attached to the Network Station or the Network Station's keyboard language, from the terminal configuration server.
- The Network Station presents a log-on screen. You are then able to enter a userid and password.
- The Authentication server validates your userid and password and allows access to personal user files.
- Your personalized environment preferences are downloaded.
- The Network Station displays your personalized desktop.

Refer to *IBM Network Station Manager Installation and Use* for more information about Network Stations.

---

### Thin Server Feature Overview

One physical device may function as the BootP/DHCP server, the boot server, the terminal configuration server, and the authentication server, or each server may be a separate device. For example, you may have a Network Station connected to an AS/400® and the AS/400 acts as the BootP server, base code server, terminal configuration server, and authentication server. Alternatively, each server may be a separate physical box. For example, the Network Station may be connected to a network where a Windows® NT server is its DHCP server, an AS/400 is its base code server, another AS/400 is its terminal configuration server, and yet another AS/400 is its authentication server.

## Using TSF

The Thin Server feature allows the 2212 to be a base code server. One example of why using the TSF would be desirable is illustrated by Figure 50 and Figure 51 on page 553. In Figure 50, any file which the Network Station requires will be downloaded from the single server. When the Network Station is powered on, the download consists of several megabytes. This could be very demanding on a network infrastructure, as well as the device acting as the base code/terminal configuration server or authentication server, especially if many Network Stations are powered on simultaneously. Figure 51 on page 553 shows the network with a Thin Server used at the remote site. Many of the files associated with the Network Station boot code will be cached by the Thin Server. When the Network Station is powered on, most of the boot code will be loaded from the Thin Server and only a small amount of data will need to be transported across the network infrastructure. This reduced processing on any single server lowers network traffic and reduces the time necessary complete the power on of a Network Station.

Since files cached by the Thin Server are copies of files that reside on the master file server, as the version on the master file server gets modified, the Thin Server needs to update its version of that file. The Thin Server will verify that all of the cached files are identical to the master file server version of those files when:

1. The IBM 2212 is powered on
2. The IBM 2212 is reloaded or restarted
3. The TSF is restarted
4. The time interval specified in the TSF configuration is reached
5. An SNMP MIB action parameter triggers it
6. The TSF talk 5 **refresh** command is issued
7. Each time a file is accessed (except TFTP). The TSF will verify that each file accessed matches the version on the master file server. When a difference is detected, that file will be updated. Then the TSF will verify that the remaining files match the master file server as well.

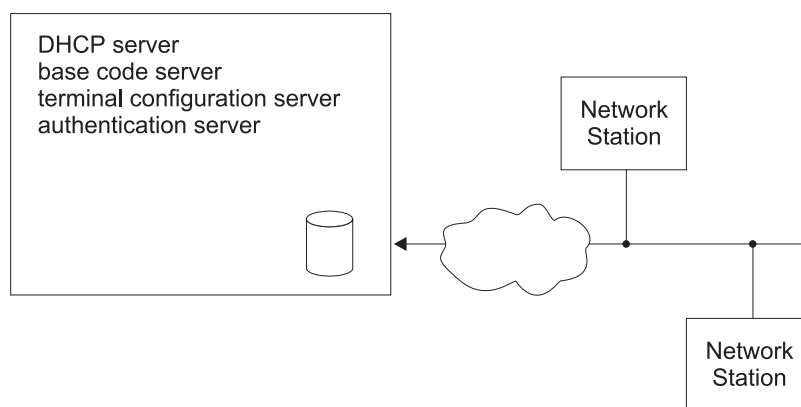

Figure 50. Remote Network Station without a Thin Server

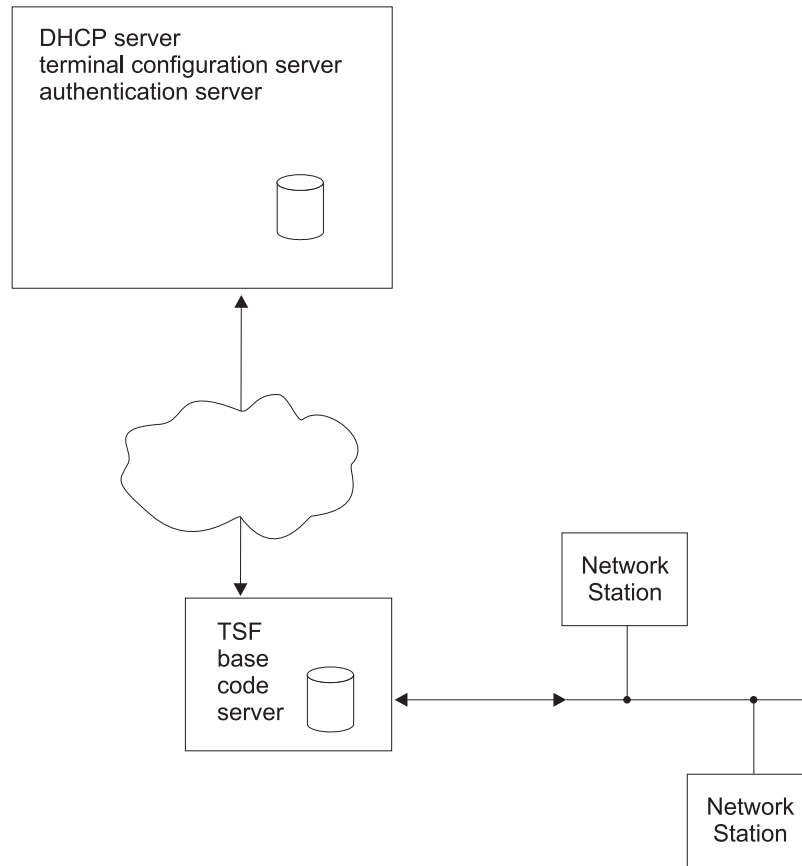

Figure 51. Remote Network Station with a Thin Server

---

## BootP/DHCP Support

You have two options for BootP/DHCP Server support:

- Use the IBM 2212 DHCP Server support. See “Chapter 32. Using DHCP Server” on page 489.
- Configure the IBM 2212 to act as a relay agent for BootP/DHCP requests. Refer to Configuring the BOOTP/DHCP Forwarding Process in the chapter Using IP of the *Protocol Configuration and Monitoring Reference Volume 1* for additional information.

Refer to *IBM Network Station Manager Installation and Use* for more information about multiple server environments.

---

## Protocols Used to Communicate with the Network Stations

The protocols used to communicate between the Network Station and its servers will be determined either by the BootP/DHCP configuration or by the Network Station NVRAM configuration. In either case, the protocols which the Network Station uses must be compatible with how the TSF is configured.

If the TSF is configured to use Remote File System (RFS) to communicate with the master file server, then it will respond to RFS and TFTP requests from the Network Stations and the TSF will not respond to any Network File System (NFS) requests from Network Stations.

## Using TSF

**NFS** The network file system is a distributed file system that provides transparent access to remote disks.

**RFS** The remote file system (AS/400-specific) is used primarily to transport files between systems.

Similarly, if the TSF is configured to use NFS to communicate with the master file server, then it will respond to NFS and TFTP requests from the Network Stations and the TSF will not respond to any RFS requests from Network Stations.

## Using RFS

The TSF establishes a connection to the AS/400 using RFS. When a Network Station makes a request to open a file, the TSF forwards that request to the AS/400 for authorization. If the Network Station is not authorized, TSF will not send the requested file to the Network Station. If the Network Station is authorized, and the AS/400 version of the requested file differs from the version stored on the IBM 2212 TSF, the Network Station request is relayed to the AS/400. If the file on the AS/400 is the same version as the file the TSF has cached, then the TSF will serve that file to the Network Station.

If the TSF is configured for disconnected mode, the TSF handles all of the Network Station traffic locally and either serves the file if it is cached, or responds File Not Found if it is not cached. Thus, it is imperative that all files that the Network Station is requesting be cached. The TSF connects to the master file server to perform the refreshes, but no file opens or per file authentication is relayed to the master file server.

If the TSF connection to the AS/400 is unavailable, or the TSF is in disconnected mode, then the TSF serves the files that it currently has cached to the Network Station.

## Using TFTP

If TFTP is being used to communicate between the Network Station and the TSF, the TSF will serve Network Station requests for files if those files are available. No verification of version is made between the TSF and the master file server. If the file is not available in the TSF cache, the request from the Network Station is forwarded to the master file server.

If the TSF is configured for disconnected mode, TSF handles all of the Network Station requests locally. If a file is not available in the TSF cache, the TSF responds File Not Found instead of relaying the request to the master file server.

## Using NFS

If NFS is being used to communicate between the Network Station and the TSF, then when a Network Station makes a request for a file, the TSF starts serving that file if it is cached. Simultaneously, it verifies that the file is the same version as the master file server. If not, then the TSF terminates the serving of the file and immediately starts downloading the new version from the master file server.

If the TSF is configured for disconnected mode, the TSF does not verify each file as it is requested.

If the TSF does not have the file cached, then the TSF responds File Not Found. In addition, if the requested file resides in a directory for which the TSF has been

configured with *include subdirectories* or resides in a sub-directory under such a configured directory, then the TSF starts caching the file, if the file exists on the master file server.

---

## File Cache Updates

The protocol used for file caching on the network device is determined by the configuration of TSF. You designate a master server using the **add master-file-server** command.

The TSF provides for configuration of two master file servers, a file server and a secondary file server. The secondary file server is a backup file server.

For both RFS and NFS master file servers, you are prompted for the address of a file server and a secondary file server. The file server address is required; the secondary file server address is optional. The file server should be the primary master file server for this TSF. If more than one server is running NSM and you want to specify a backup or alternate file server that the TSF is to use when the server specified as the file server is unavailable, then you may specify a secondary file server. If no secondary master file server exists, set the secondary file server address to 0.0.0.0. It is recommended that both master file servers be running the same version of NSM, and if using RFS it is recommended that both pre-load lists be identical; otherwise the Network Station behavior may change when the TSF switches to the secondary master file server.

The switching or selection of either the file server or the secondary file server is controlled by the Talk 6 **set selection** command. You may set the selection to primary, secondary, or automatic. Setting the selection to primary causes the secondary file server to be ignored; only the primary is contacted. If the primary server is not contacted after the configured number of retries, then the TSF stops trying to contact it until the next refresh. Setting the selection to secondary causes the primary file server address to be ignored; only the secondary file server is contacted. If the secondary file server is not contacted after the configured number of retries, then the TSF stops trying to contact it until the next refresh. Setting the selection to automatic causes TSF to try to contact the primary file server. If it is not contacted after the configured number of retries, then the TSF automatically tries to connect to the secondary file server.

If you specify *rfs*, you are prompted to specify a pre-load list file name. The pre-load list is an ASCII file that specifies the fully-qualified file name of every file that the TSF is to cache.

If you specify *nfs*, you are prompted for directory names to be cached (some defaults may be provided). When you specify a directory, you are prompted to specify whether or not to include subdirectories. Specifying *no* (do not include subdirectories) causes the TSF to pre-load all files in the specified directory into the TSF cache. Specifying *yes* (include subdirectories) causes the TSF to *not* pre-load any files from that directory, but instead to dynamically retrieve files from that directory and any of its subdirectories as Network Stations request those files.

Files that are in the process of being refreshed are not sent to the Network Station during this process.

---

## Configuring the Thin Server Environment

When the TSF is installed, there are several configurations beyond that of the TSF itself which may need to be considered. This section discusses the changes which may be necessary to the BootP/DHCP server, the master file server, the IBM 2212 BootP Relay, the IBM 2212 Internal IP address, and the IBM 2212 TSF configuration. An example of a Thin Server connecting to an AS/400 running Network Station Manager (NSM) Release 2.5 is discussed in “Sample Configuration” on page 558.

The following sections describe the Thin Server environment configuration process:

- “Configuration Recommendations”
- “Configuring the BootP/DHCP Server” on page 557
- “Configuring the Server for the Thin Server Environment” on page 557
- “Configuring BootP Relay” on page 557
- “Configuring the Internal IP Address” on page 558
- “Configuring the TSF” on page 558
- “Sample Configuration” on page 558

### Configuration Recommendations

The following are configuration recommendations to help you get the most from the TSF:

- Use a hardfile.

While the TSF does not require a hardfile, it will improve your performance if the TSF memory cache is configured too small (or cannot be configured large enough because of other functions in the 2212), and a hardfile will improve performance if the TSF or 2212 is restarted or reloaded.

- Maximum number of Network Stations.

The TSF will allow up to 200 RFS Network Station connections at one time. Simultaneously powering on more than 30 to 40 Network Stations may result in delays which exceed Network Station timeout values. Recovery may require the Network Station to be re-powered on.

- The master file server should be a server running Network Station Manager (NSM). Both the primary and secondary master file servers should be using the same version of NSM.

While the TSF allows the master file server IP address to be any value, it is recommended that this be the address of a device that is running NSM so that the file structure is compatible with the Network Station and hence the TSF, and it can provide the files that the TSF will ask for.

- Define sufficient memory to contain all of the cached files in memory.

This is required if you do not have a hardfile. If you do have a hardfile, memory access is much quicker than hardfile access. The amount of memory needed will vary depending on your specific environment. Use the `Talk 5 list config` command to determine how large your file set is at a particular instance in time. The value displayed for *Hard File storage being used for Thin Server* is the size of your file set in kilobytes. However, if different types of Network Stations or applications are added to or removed from your environment, this value may change.

- If you are using NFS, the TSF learns which files it needs.

This learning process may take several Network Station power-on sequences for TSF to identify all the needed files.

- If the TSF is configured for disconnected mode, make sure that it is caching all necessary files.

If the TSF is configured for disconnected mode, then all files requested from the TSF by the Network Station must be cached by the Thin Server. If using RFS, the pre-load list must contain all necessary files. If using NFS, the TSF must be configured to cache the appropriate directories. (The TSF will still learn/download files as necessary.) If the pre-load list or appropriate directories are not configured correctly, then Network Stations may not boot correctly. One way to ensure that the configuration is correct is to run TSF in Enabled mode and monitor the appropriate ELS messages and TSF counters before running in disconnected mode.

## Configuring the BootP/DHCP Server

When running Network Station Manager Release 3, DHCP is required when you are using a Thin Server. If you are using an AS/400 as the master file server, then Network Station Manager Release 2.5 may be used, in which case BootP may be used instead of DHCP.

For BootP, only one server address can be specified. That address is specified by using the **sa** tag. This tag may or may not already exist in the BootP record for a given Network Station. If it does not exist, then create it and set the value to the 2212's Internal IP address. If it already exists, then change it to the 2212's Internal IP address.

For DHCP, the fields that may need to be modified when the Thin Server is used are as follows:

- Option 66 or bootstrap server - base code server IP address  
This value should be set to the IBM 2212 Internal IP address
- Option 211 - protocol to use for the base code server  
If the Thin Server is being configured for a master-file-server type of NFS, then this must be either *nfs* or *tftp*. If the Thin Server is being configured for a master-file-server type of RFS, then this must be either *rfs/400* or *tftp*.
- Option 212 - terminal configuration server  
This address should be the same as the master-file-server IP address.

For more details about how NSs interact with BootP and DHCP, refer to *IBM Network Station Manager Installation and Use*.

## Configuring the Server for the Thin Server Environment

For RFS, the pre-load list must be installed on the AS/400. The preload list is available on the internet at <http://www.networking.ibm.com/netprod.html#routers>. You should ftp the LoadList.file from this site and place it in /QIBM/ProdData/OS400/NetStationRmtController on the AS/400. The NetStationRmtController directory may need to be created.

For NFS, no special changes on the master server are necessary for the Thin Server.

## Configuring BootP Relay

The IBM 2212's BootP Relay agent should be enabled and the appropriate BootP and DHCP servers should be configured so the BootP Relay will forward to those servers. Refer to *Access Integration Services Software User's Guide* for more information.

## Using TSF

### Configuring the Internal IP Address

If an Internal IP address already exists, no special change is necessary. If no Internal IP address is currently specified, one should be specified. Refer to *Protocol Configuration and Monitoring Reference Volume 1* for more information.

### Configuring the TSF

Use the commands discussed in “Chapter 35. Configuring and Monitoring Thin Server Function” on page 563 to configure the Thin Server.

Minimally, the following commands must be entered:

1. **load add package thin-server**
2. **set mode enable** or **set mode disconnected**
3. **add master-server**

---

## Sample Configuration

The following example configures a TSF going to an AS/400 that is running Network Station Manager R2.5.

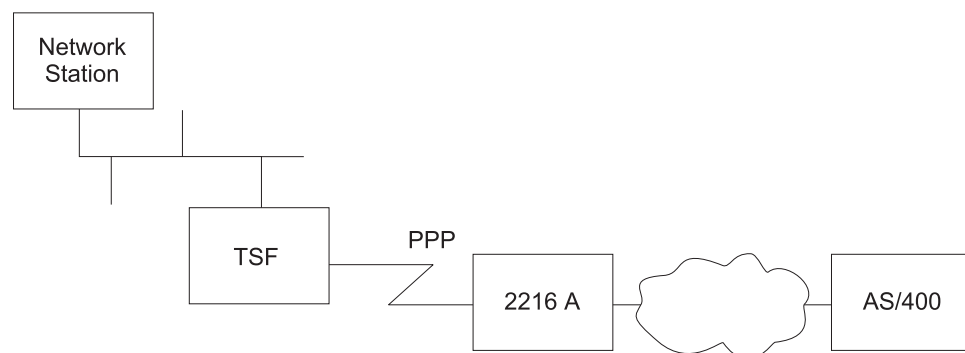

Figure 52. TSF Sample Configuration

This discussion describes configuring the Thin Server Feature based on the above network and with the following assumptions:

- The AS/400 will be the BootP server.
- The 2216 A is a router (no TSF configured and no special configuration for TSF).
- The network IP connectivity has been validated, i.e. the AS/400 can PING the IBM 2212 (TSF) and the IBM 2212 can PING the AS/400.
- BootP Relay is NOT currently enabled in the IBM 2212 (TSF)
- An IP Internal Address is NOT currently configured in the IBM 2212 (TSF)

## Configuring the AS/400

### BootP (NSM Release 2.5)

1. Use NSM to define the NS
2. ftp the BootP table to a system which has an ASCII editor

```
c:\>ftp as400a
Connected to as400a.raleigh.ibm.com.
220-QTCP at AS400A.RALEIGH.IBM.COM.
220 Connection will close if idle more than 5 minutes.
Name (as400a:goofy): qsecofr
331 Enter password. Password:
```



```
230 QSECOFR logged on.
ftp> ascii
ftp> get qusrsys/qatodbtp.bootptab bootp.tab
ftp> quit
```

3. Edit the file using an ASCII editor, adding a "sa" tag with the 2212 (TSF)'s Internal IP address specified:

```
OLD LINE
-----
NSEN106:ip=192.9.250.36:bt=IBMNSM:ht=1:ha=00.00.A7.01.2E.35:
sm=255.255.248.0:gw=192.9.250.6:bf=KERNEL:
hd=/QIBM/PRODDATA/NETWORKSTATION

MODIFIED LINE
-----
NSEN106:ip=192.9.250.36:bt=IBMNSM:ht=1:ha=00.00.A7.01.2E.35:
sm=255.255.248.0:gw=192.9.250.6:bf=KERNEL:
hd=/QIBM/PRODDATA/NETWORKSTATION:sa=192.9.250.6
```

where 192.9.250.6 is the 2212 (TSF)'s Internal IP address

4. ftp the BootP table back to the AS/400

```
c:\> ftp as400a
Connected to as400a.raleigh.ibm.com.
220-QTCP at AS400A.RALEIGH.IBM.COM.
220 Connection will close if idle more than 5 minutes.
Name (as400a:goofy): qsecofr
331 Enter password.
Password:
230 QSECOFR logged on.
ftp> ascii
ftp> put bootp.tab qusrsys/qatodbtp.bootptab
ftp> quit
```

### Setting up the Pre-load List

You can obtain a Pre-load list from the internet:

<http://www.networking.ibm.com/netprod.html#routers>

Once you have the preload list you can "ftp" it to the AS/400.

1. Make sure your local directory is set to the location of the "LoadList.file".
2. ftp to your AS/400 - "test400" is the name of the AS/400 in this example.

```
ftp test400
Connected to test400.raleigh.ibm.com.
Name (test400:root): qsecofr
Enter password.
Password:
QSECOFR logged on.
```

3. Change to the correct directory on the target AS/400:

```
ftp> cd /
Current directory changed to /.
ftp> cd qibm/proddata/os400/
Current directory changed to /qibm/proddata/os400.
ftp> dir
PORT subcommand request successful.
List started.
QTCP          34816 04/30/97 02:50:36 *DIR      REXEC/
QSECOFR       33792 07/24/98 08:04:55 *DIR      NetStationRmtController/
List completed.
```

4. If the directory "NetStationRmtController" does not exist you will need to create it.

## Using TSF

```
ftp> MKD
(directory - name) NetStationRmtController
Created directory /qibm/proddata/os400/netstationrmtcontroller
```

5. Change to the NetStationRmtController directory:

```
ftp> cd NetStationRmtController
Current directory changed to /qibm/proddata/os400/Netstationrmtcontroller.
```

6. Transfer the file to the AS/400:

```
ftp> ascii
Representation type is ASCII nonprint.
ftp> put LoadList.file
PORT subcommand request successful.
Sending file to /qibm/proddata/os400/Netstationrmtcontroller
File transfer completed successfully.
```

## Configuring TCP/IP

Your TCP/IP configuration will depend on your specific environment.

## Configuring the IBM 2212 (TSF)

### BootP Relay

1. Determine if BootP relay is already configured:

```
*
*
t 6
Config>protocol ip
Internet protocol user configuration
IP config>list bootp
BOOTP forwarding: enabled
Max number of BOOTP forwarding hops: 4
Min secs of retry before forwarding: 0
Configured BOOTP servers:      192.9.220.21
IP config>
```

2. If it is not already enabled, then enable it:

```
IP config>enable bootp
Maximum number of forwarding hops [4]?
Minimum seconds before forwarding [0]?
IP config>
```

3. If your Network Station BootP or DHCP server is not in the list of configured servers, then add it:

```
IP config>add bootp-server
BOOTP server address [0.0.0.0]? 9.37.121.6
IP config>
```

### Internal IP Address

1. Determine if an internal IP address has already been configured:

```
Config>protocol ip
Internet protocol user configuration
IP config>list addresses
IP addresses for each interface:
  intf   0   9.37.177.97      255.255.248.0   Local wire...
  intf   1  192.9.220.2      255.255.255.0   Local wire...
  intf   2  192.9.250.6      255.255.255.0   Local wire...
  intf   3  192.9.222.2      255.255.255.0   Local wire...
  intf   4
  intf   5
  intf   6  192.9.223.2      255.255.255.0   Local wire...
IP config>
```

2. Configure the Internal IP Address.

```
IP config>set internal-ip-address
Internal IP address [192.9.223.2]? 192.9.250.6
IP config>
```

### 3. List the addresses again.

```
IP config>list addresses
IP addresses for each interface:
  intf    0  9.37.177.97      255.255.248.0   Local wire
  intf    1  192.9.220.2          255.255.255.0   Local wire
  intf    2  192.9.250.6          255.255.255.0   Local wire
  intf    3  192.9.222.2          255.255.255.0   Local wire
  intf    4                                     IP disabled
  intf    5                                     IP disabled
  intf    6  192.9.223.2          255.255.255.0   Local wire
Internal IP address: 192.9.250.6
IP config>
```

## Thin Server Feature

### 1. Add load package thin-server

Before the Thin Server feature can be configured, you must add the load package.

First, check to make sure that the thin server package is available.

```
Config>load list available
Available Packages
-----
appn package
tn3270e package
thin-server package
Config>
```

If it is not available, then you need to get the correct software version before proceeding.

If it is available, verify that the package is not already loaded.

```
Config>load list configured
Configured Packages
-----
thin-server package
Config>
```

If it is already loaded/configured (as shown above), then you can proceed to configuring TSF. If it is not already loaded, then you need to add the Thin Server package:

```
Config>load add package thin-server
thin-server package configured successfully
This change requires a reload.
Config>
```

### 2. Reload

If you had to add the Thin Server package, then you must now write the configuration and reload the IBM 2212.

### 3. Set mode

When the package is loaded, the Thin Server is initially disabled. The mode must be set to enable, disconnected, or passthru before any other Thin Server parameters can be configured.

```
*
*
t 6
Config>feature tsf
```

## Using TSF

```
Thin server config>set mode enable
```

```
Thin server feature (TSF) is fully enabled once
you have entered a Master File Server for either
RFS or NFS. Please add a master-file-server if
one is not already configured.
Thin server config>
```

### 4. Add master-file-server.

Once the Thin Server feature is enabled, the master file server must be configured. In this example, the master file server is an AS/400 so we will add an RFS master file server. For this network, the default TFTP timeout and retry parameters are adequate.

```
Thin server config>add master-file-server rfs-as400
File Server IP address [0.0.0.0]? 192.9.221.21
Secondary File Server IP address [0.0.0.0]? 192.9.225.20
Master Server Refresh Retry Limit (1 - 20) [10]?
TFTP Packet Timeout in seconds (5 - 10) [5]?
TFTP Max Retry Limit (1 - 10) [1]? 7
TFTP Max Segment Size in bytes (valid values are 512, 1024, 2048, 4096, 8192)
[8192]?
Pre-load File name
[/QIBM/ProdData/OS400/NetstationRmtController/Loadlist.file]?
Thin server config>
```

Our AS/400's IP address on the Token-Ring interface is 9.37.100.68. When we installed the pre-load list file onto the AS/400 we assigned its name to match the Thin Server default name, so that does not need to be modified.

### 5. Set time-to-refresh-pre-load-list (optional)

The default for the time of day to perform the refresh is 1:00 AM. This was chosen to minimize any performance impacts if large files have been modified and need to be downloaded by the Thin Server.

### 6. Set interval-pre-load-list (optional)

The default interval for verifying the cached files are at the same level as the master-file-server is every day. The value for this parameter and the time-to-refresh-pre-load-list parameter determine how often the files are verified. If the network station files change infrequently, then perhaps you would want to set these to only refresh once a week or once a month.

### 7. Set memory (optional)

The default memory of a 16-MB RAM cache for file caching should be sufficient. Once several Network Stations are using TSF, see "Configuration Recommendations" on page 556 for recommended values.

### 8. Set hard file (optional)

A hard-file is recommended. If you do not have a hard file, then this parameter should be set to *no*.

### 9. Set selection (optional)

The default value is primary. If you have a secondary master file server, you may want to specify automatic selection. See "File Cache Updates" on page 555 for details.

---

## Chapter 35. Configuring and Monitoring Thin Server Function

This chapter describes how to use the Thin Server Function (TSF) configuration and operating commands and includes the following sections:

- “Accessing the TSF Configuration Environment”
- “TSF Configuration Commands”
- “Accessing the TSF Monitoring Environment” on page 574
- “TSF Monitoring Commands” on page 575
- “TSF Dynamic Reconfiguration Support” on page 580

---

### Accessing the TSF Configuration Environment

Use the following procedure to access the TSF configuration process.

1. At the OPCON prompt, enter **talk 6**. (For more detail on this command, refer to “The OPCON Process and Commands” in *Access Integration Services Software User’s Guide*.) For example:

```
* talk 6
Config>
```

After you enter the **talk 6** command, the CONFIG prompt (Config>) displays on the terminal. If the prompt does not appear when you first enter configuration, press **Return** again.

2. At the CONFIG prompt, enter the **feature tsf** command to get to the Thin server config> prompt.

---

### TSF Configuration Commands

To configure TSF, enter the commands at the Thin server config> prompt.

Table 62. TSF Configuration Command Summary

Command	Function
? (Help)	Displays all the commands available for this command level or lists the options for specific commands (if available). See “Getting Help” on page xxxii.
Add	Adds master file server—Remote File System (RFS) or Network File System (NFS).
Delete	Deletes master file server (RFS or NFS).
List	Lists the thin server configuration.
Modify	Modifies master file server (RFS or NFS).
Set	Sets the thin server parameters.
Exit	Returns you to the previous command level. See “Exiting a Lower Level Environment” on page xxxii.

#### Add

Use the **add** command to add a master file server configuration.

If you select *nfs* as the master-file-server type, the Thin Server will use NFS to communicate with the master file server and synchronize files and NSs can communicate with the Thin Server using TFTP or NFS. If you select *rfs* as the master-server type, then the Thin Server will use RFS to communicate with the master file server and synchronize files and NSs can communicate with the Thin Server using TFTP or RFS.

#### Syntax:

## TSF Configuration Commands (Talk 6)

**add master-file-server**      nfs-s390  
   nfs-nt  
   nfs-aix  
   nfs-other  
   rfs-as400

### **nfs-s390**

Used when the TSF is connected to a S/390®.

#### **File Server IP address**

Specifies the IP address of the master file server.

**Valid Values:** any valid IP address

**Default Value:** 0.0.0.0

#### **Secondary File Server IP address**

Specifies the IP address of a backup master file server. See “File Cache Updates” on page 555 for details. See the **set selection** command for a description of how this parameter is used.

**Note:** This cannot be set to 0.0.0.0 if the **set selection** command specifies either secondary or automatic.

**Valid Values:** any valid IP address

**Default Value:** 0.0.0.0

#### **Master Server Refresh Retry Limit**

Specifies the number of times that the TSF will retry before declaring a master file server as unreachable.

**Range:** 1 to 20

**Default Value:** 10

#### **tftp packet timeout**

**Valid Values:** 5 - 10 seconds

**Default Value:** 5

#### **tftp maximum retry limit**

**Valid Values:** 1 - 10

**Default Value:** 1

#### **maximum segment size**

Specifies the maximum packet segment size.

**Valid Values:** 512, 1024, 2048, 4096, 8192 (bytes)

**Default Value:** 8192

#### **additional Include subdirectories**

Specifies whether additional Included subdirectories are to be added. Additional subdirectories may be specified if the TSF needs to cache files that are not in the default directories.

**Valid Values:** yes or no

**Default Value:** yes

#### **additional Include subdirectory path**

Specifies the path of the Include subdirectory to be added.

## TSF Configuration Commands (Talk 6)

**Valid Values:** a-z, A-Z, 0-9, ., \_, —, /

**Default Value:** none

### **include all subdirectories under this directory**

Specifies whether all nested subdirectories in the specified additional subdirectory path will be included.

**Valid Values:**

- No  
The TSF will pre-load all files in the specified directory.
- Yes  
The TSF will not pre-load any files in the specified directory. Instead the TSF will load files from the directory and any of its sub-directories as needed.

**Default Value:** no

**nfs-nt** Used when the TSF is connected to Windows NT.

### **File Server IP address**

Specifies the IP address of the master file server.

**Valid Values:** any valid IP address

**Default Value:** 0.0.0.0

### **Secondary File Server IP address**

Specifies the IP address of a backup master file server. See “File Cache Updates” on page 555 for details. See the **set selection** command for a description of how this parameter is used.

**Note:** This cannot be set to 0.0.0.0 if the **set selection** command specifies either secondary or automatic.

**Valid Values:** any valid IP address

**Default Value:** 0.0.0.0

### **Master Server Refresh Retry Limit**

Specifies the number of times that the TSF will retry before declaring a master file server as unreachable.

**Range:** 1 to 20

**Default Value:** 10

### **tftp packet timeout**

**Valid Values:** 5 - 10 seconds

**Default Value:** 5

### **tftp max retry limit**

**Valid Values:** 1 - 10

**Default Value:** 1

### **maximum segment size**

Specifies the maximum packet segment size.

**Valid Values:** 512, 1024, 2048, 4096, 8192 (bytes)

**Default Value:** 8192

## TSF Configuration Commands (Talk 6)

### **additional Include subdirectories**

Specifies whether additional Included subdirectories are to be added.

**Valid Values:** yes or no

**Default Value:** yes

### **additional Include subdirectory path**

Specifies the path of the Include subdirectory to be added.

**Valid Values:** a-z, A-Z, 0-9, ., \_, —, /

**Default Value:** none

### **include all subdirectories under this directory**

Specifies whether all nested subdirectories in the specified additional subdirectory path will be included.

**Valid Values:**

- No  
The TSF will pre-load all files in the specified directory.
- Yes  
The TSF will not pre-load any files in the specified directory. Instead the TSF will load files from the directory and any of its sub-directories as needed.

**Default Value:** no

## **nfs-aix**

Used when the TSF is connected to AIX®.

### **File Server IP address**

Specifies the IP address of the master file server.

**Valid Values:** any valid IP address

**Default Value:** 0.0.0.0

### **Secondary File Server IP address**

Specifies the IP address of a backup master file server. See “File Cache Updates” on page 555 for details. See the **set selection** command for a description of how this parameter is used.

**Note:** This cannot be set to 0.0.0.0 if the **set selection** command specifies either secondary or automatic.

**Valid Values:** any valid IP address

**Default Value:** 0.0.0.0

### **Master Server Refresh Retry Limit**

Specifies the number of times that the TSF will retry before declaring a master file server as unreachable.

**Range:** 1 to 20

**Default Value:** 10

### **tftp packet timeout**

**Valid Values:** 5 - 10 seconds

**Default Value:** 5



### **tftp maximum retry limit**

**Valid Values:** 1 - 10

**Default Value:** 1

### **maximum segment size**

Specifies the maximum packet segment size.

**Valid Values:** 512, 1024, 2048, 4096, 8192 (bytes)

**Default Value:** 8192

### **additional Include subdirectories**

Specifies whether additional Included subdirectories are to be added.

**Valid Values:** yes or no

**Default Value:** yes

### **additional Include subdirectory path**

Specifies the path of the Include subdirectory to be added.

**Valid Values:** a-z, A-Z, 0-9, ., \_, —, /

**Default Value:** none

### **include all subdirectories under this directory**

Specifies whether all nested subdirectories in the specified additional subdirectory path will be included.

**Valid Values:**

- No

The TSF will pre-load all files in the specified directory.

- Yes

The TSF will not pre-load any files in the specified directory. Instead the TSF will load files from the directory and any of its sub-directories as needed.

**Default Value:** no

### **nfs-other**

Used when you want to manually designate all of the subdirectories.

#### **File Server IP address**

Specifies the IP address of the master file server.

**Valid Values:** any valid IP address

**Default Value:** 0.0.0.0

#### **Secondary File Server IP address**

Specifies the IP address of a backup master file server. See “File Cache Updates” on page 555 for details. See the **set selection** command for a description of how this parameter is used.

**Note:** This cannot be set to 0.0.0.0 if the **set selection** command specifies either secondary or automatic.

**Valid Values:** any valid IP address

**Default Value:** 0.0.0.0

## TSF Configuration Commands (Talk 6)

### **Master Server Refresh Retry Limit**

Specifies the number of times that the TSF will retry before declaring a master file server as unreachable.

**Range:** 1 to 20

**Default Value:** 10

### **tftp packet timeout**

**Valid Values:** 5 - 10 seconds

**Default Value:** 5

### **tftp maximum retry limit**

**Valid Values:** 1 - 10

**Default Value:** 1

### **maximum segment size**

Specifies the maximum packet segment size.

**Valid Values:** 512, 1024, 2048, 4096, 8192 (bytes)

**Default Value:** 8192

### **additional Include subdirectories**

Specifies whether additional Included subdirectories are to be added.

**Valid Values:** yes or no

**Default Value:** yes

### **additional Include subdirectory path**

Specifies the path of the Include subdirectory to be added.

**Valid Values:** a-z, A-Z, 0-9, ., \_, —, /

**Default Value:** none

### **include all subdirectories under this directory**

Specifies whether all nested subdirectories in the specified additional subdirectory path will be included.

**Valid Values:**

- No

The TSF will pre-load all files in the specified directory.

- Yes

The TSF will not pre-load any files in the specified directory.

Instead the TSF will load files from the directory and any of its sub-directories as needed.

**Default Value:** no

### **rfs-as400**

Used when the TSF is connected to an AS/400.

#### **File Server IP address**

Specifies the IP address of the master file server.

**Valid Values:** any valid IP address

**Default Value:** 0.0.0.0

## TSF Configuration Commands (Talk 6)

### Secondary File Server IP address

Specifies the IP address of a backup master file server. See “File Cache Updates” on page 555 for details. See the **set selection** command for a description of how this parameter is used.

**Note:** This cannot be set to 0.0.0.0 if the **set selection** command specifies either secondary or automatic.

**Valid Values:** any valid IP address

**Default Value:** 0.0.0.0

### Master Server Refresh Retry Limit

Specifies the number of times that the TSF will retry before declaring a master file server as unreachable.

**Range:** 1 to 20

**Default Value:** 10

### tftp packet timeout

**Valid Values:** 5 - 10 seconds

**Default Value:** 5

### tftp maximum retry limit

**Valid Values:** 1 - 10

**Default Value:** 1

### maximum segment size

Specifies the maximum packet segment size.

**Valid Values:** 512, 1024, 2048, 4096, 8192 (bytes)

**Default Value:** 8192

### pre-load file name

Specifies the name and path of the pre-load file.

**Valid Values:** a-z, A-Z, 0-9, ., \_, —, /

**Default Value:**

/QIBM/ProdData/OS400/NetStationRmtController/LoadList.file

### Example: For NFS

```
Thin server config> add master-file-server nfs-nt
File Server IP address [0.0.0.0]? 10.22.55.94
Secondary File Server IP address [0.0.0.0]? 10.22.55.96

Master Server Refresh Retry Limit (1-20) [10]?

TFTP Packet Timeout in seconds (5 - 10) ][5]?

TFTP Max Retry Limit (1 - 10) [1]?

TFTP Max Segment Size in bytes (valid values are 512, 1024, 2048, 4096, 8192) [8192]?

Default Include Directories:

Include Directory List Follows:

Include
all
```

## TSF Configuration Commands (Talk 6)

Subdirs?	Directory Names
N	/netstation/prodbase
Y	/netstation/prodbase/mods
Y	/netstation/prodbase/nls
Y	/netstation/prodbase/fonts
Y	/netstation/prodbase/java
Y	/netstation/prodbase/keyboards
Y	/netstation/prodbase/proms
Y	/netstation/prodbase/X11
Y	/netstation/prodbase/configs
Y	/netstation/prodbase/SysDef
Y	/netstation/prodbase/zoneinfo

Do you want additional Include Subdirectories (Y)es (N)o [N]? **y**

Include Subdirectory [ ]? **/netstation/prodbase/another**

Include all subdirectories under this directory (Y)es or (N)o [N]?

Do you want additional Include Subdirectories (Y)es (N)o [N]?

### Example: For RFS

```
Thin server config> add master-file-server rfs
File Server IP address [0.0.0.0]? 192.9.225.21
Secondary File Server IP address [0.0.0.0]? 192.9.225.20
Master Server Refresh Retry Limit (1-20) [10]?
TFTP Packet Timeout in seconds (5-10) [5]?
TFTP Max Retry Limit (1-10) [1]?
TFTP Max Segment Size in bytes (valid values are 512, 1024, 2048, 4096, 8192) ][8192]?

Pre-Load File name
[/QIBM/ProdData/OS400/NetStationRmtController/LoadList.file]?
```

## Delete

Use the **delete** command to remove a master file server configuration.

### Syntax:

```
delete master-file-server      nfs
                                rfs
```

**nfs** Used when any of the NFS master file servers is configured.

**rfs** Used when the TSF is configured for the RFS master file server.

## List

Use the **list** command to display the TSF configuration.

### Syntax:

```
list all
```

### Example: For NFS

```
Thin server config> list all
```

Thin Server Feature configuration:

```
Mode:                               ENABLED
Master File Server Selection: PRIMARY
Interval to refresh cache in day(s): 1
Time of day (military time) to refresh cache: 0100
Megabytes used for Thin Server RAM cache: 16
Use Hard File: YES
```

```

Master Thin Server list:
  Server IP Address: 192.9.221.21
  Secondary Server IP Address: 192.9.225.20
  Server Protocol: NFS

  Master Server Refresh Retry Limit value: 10
  TFTP Packet Timeout value: 5
  TFTP Maximum Retry Limit value: 6
  TFTP Maximum Segment Size value: 512

  Initial directories setup for server type: NFS-AIX
  
```

NFS Include Directory List follows:

```

Include
  all
subdirs?  Directory Names
-----  -----
          /usr/netstation
          /usr/netstation/mods
          /usr/netstation/nls
          /usr/netstation/fonts
          /usr/netstation/java
          /usr/netstation/keyboards
          /usr/netstation/proms
          /usr/netstation/X11
          /usr/netstation/configs
          /usr/netstation/SysDef
          /usr/netstation/zoneinfo
  
```

### Example: For RFS

```
Thin server config> list all
```

Thin Server Feature configuration:

```

Mode: DISCONNECTED
Master File Server Selection: PRIMARY
Interval to refresh cache in day(s): 1
Time of day (military time) to refresh cache: 0100
Megabytes used for Thin Server RAM cache: 16
Use Hard File: YES
  
```

```

Master Thin Server list:
  Server IP Address: 192.9.221.21
  Secondary Server IP Address: 192.9.225.20
  Server Protocol: RFS
  
```

```

  Master Server Refresh Retry Limit value: 10
  TFTP Packet Timeout value: 5
  TFTP Maximum Retry Limit value: 1
  TFTP Maximum Segment Size value: 8192
  
```

```

Protocol RFS List:
  Pre-load File: /QIBM/ProdData/OS400/NetStationRmtcontroller/Loadlist.file
  
```

## Modify

Use the **modify** command to modify a master file server configuration.

### Syntax:

```
modify master-file-server nfs
```

## TSF Configuration Commands (Talk 6)

rfs

**nfs** Used when one of the NFS master file servers has been configured.

**rfs** Used when the TSF is configured for the RFS master file server.

### Example: For NFS

```
Thin server config> modify master-file-server nfs
File Server IP address [1.1.1.1]?
Secondary File Server IP address [1.1.1.2]?

Master Server Refresh Retry Limit (1 - 20) [10]?

TFTP Packet timeout in seconds (5 - 10) [5]?

TFTP Max retry limit value (1 - 10) [1]?

TFTP Max Segment Size in bytes (valid values are 512, 1024, 2048, 4096, 8192) [8192]?
Include directory /netstation/prodbase, (Y)es or (N)o [Y]?
    Include all subdirectories under this directory (Y)es or (N)o [N]?
Include directory /netstation/prodbase/mods, (Y)es or (N)o [Y]?
    Include all subdirectories under this directory (Y)es or (N)o [Y]?
Include directory /netstation/prodbase/nls, (Y)es or (N)o [Y]?
    Include all subdirectories under this directory (Y)es or (N)o [Y]?
Include directory /netstation/prodbase/fonts, (Y)es or (N)o [Y]?
    Include all subdirectories under this directory (Y)es or (N)o [Y]?
Include directory /netstation/prodbase/java, (Y)es or (N)o [Y]?
    Include all subdirectories under this directory (Y)es or (N)o [Y]?
Include directory /netstation/prodbase/keyboards, (Y)es or (N)o [Y]?
    Include all subdirectories under this directory (Y)es or (N)o [Y]?
Include directory /netstation/prodbase/proms, (Y)es or (N)o [Y]?
    Include all subdirectories under this directory (Y)es or (N)o [Y]?
Include directory /netstation/prodbase/X11, (Y)es or (N)o [Y]?
    Include all subdirectories under this directory (Y)es or (N)o [Y]?
Include directory /netstation/prodbase/configs, (Y)es or (N)o [Y]?
    Include all subdirectories under this directory (Y)es or (N)o [Y]?
Include directory /netstation/prodbase/SysDef, (Y)es or (N)o [Y]?
    Include all subdirectories under this directory (Y)es or (N)o [Y]?
Include directory /netstation/prodbase/zoneinfo, (Y)es or (N)o [Y]?
    Include all subdirectories under this directory (Y)es or (N)o [Y]?

Do you want additional Include Subdirectories (Y)es (N)o [N]?
Thin server config>
```

### Example: For RFS

```
Thin server config> modify master-file-server rfs
File Server IP address [192.9.225.21]? 192.9.225.23
Secondary File Server IP address [192.9.225.20]? 192.9.225.22
Master Server Refresh Retry Limit (1-20) [10]? 8
TFTP Packet Timeout in seconds (5-10) [5]? 7
TFTP Max Retry Limit (1-10) [1]? 15
TFTP Max Segment Size in bytes (valid values are 512, 1024, 2048, 4096, 8192) [8192]? 4096

Pre-Load File name [/QIBM/ProdData/OS400/NetStationRmtController/LoadList.file]?
```

## Set

Use the **set** command to set TSF configuration parameters.

### Syntax:

```
set mode
      selection
      interval-pre-load-list
      time-to-refresh-pre-load-list
```

## TSF Configuration Commands (Talk 6)

memory-cache  
hard-file

**mode** Specifies the mode of the TSF.

**Valid Values:**

**enable**

Specifies that the TSF is fully functional and will serve cached files to Network Stations.

**disable**

Specifies that the TSF is not active and will not respond to any Network Stations. Network Stations should be configured to communicate directly to the server.

**passthru**

Passthru mode is only valid when using RFS. Passthru allows the Network Station to contact the TSF, but always gets files from the master file server.

**disconnected**

Specifies that the TSF is functional and will serve cached files to Network Stations. However, traffic to the master file server is minimized. See "Protocols Used to Communicate with the Network Stations" on page 553 for details.

**Default Value:** disable

**selection**

Specifies whether the TSF will contact the file server IP address or the secondary file server IP address for the refresh of the TSF cache.

**Valid Values:**

**primary**

Specifies that the TSF only uses the IP address in the file server IP address when trying to refresh the cache. The secondary file server IP address is ignored.

**secondary**

Specifies that the TSF uses only the IP address in the secondary file server IP address when trying to refresh the cache. The file server IP address is ignored.

**automatic**

Specifies that the TSF will try to contact the IP address specified in the file server IP address. If it is unsuccessful after the configured number of retries, then the TSF will try to contact the IP address specified in the secondary file server IP address. See "File Cache Updates" on page 555 for details.

**Default Value:** primary

**interval-pre-load-list**

Specifies the interval (in days) at which to refresh the pre-load list in cache.

**Valid Values:** 00 - 365

**Default Value:** 01

## TSF Configuration Commands (Talk 6)

### **time-to-refresh-pre-load-list**

Specifies the time of day (24-hour format) at which to refresh the cached files.

**Valid Values:** 0001 - 2400

**Default Value:** 0100

### **memory-cache**

Specifies the amount of memory in megabytes for Thin Server RAM cache. When using a hard file, this value should be chosen so as to balance the performance of TSF with other functions in the IBM 2212. When not using a hard file, this value should be large enough to hold all cached files. For more information, see "Configuration Recommendations" on page 556.

**Valid Values:** 8 - 64 Megabytes

**Default Value:** 16

### **hard-file**

Specifies whether to use the hard file.

**Valid Values:** yes or no

**Default Value:** yes

### **Example:**

```
Thin server config> set mode passthru
This server feature (TSF) is passthru
Thin server config> set interval-pre-load-list
Interval to refresh the Pre-Load list in days (00-365) [01]? 1
Thin server config> set time-to-refresh-pre-load-list
Time of day to refresh cache in military time (0001-2400) [0100] 0800
Thin server config> set memory-cache
Amount of memory in megabytes for Thin Server RAM cache (8-64MB) [8]
Thin server config> set hard-file
Use the Hard File (Y)ex N(o) [Y]? yes
```

---

## Accessing the TSF Monitoring Environment

Use the following procedure to access the TSF monitoring commands. This process gives you access to the TSF *monitoring* process.

1. At the OPCON prompt, enter **talk 5**. (For more detail on this command, refer to *The OPCON Process and Commands* in the Access Integration Services Software User's Guide.) For example:

```
* talk 5
+
```

After you enter the **talk 5** command, the GWCON prompt (+) displays on the terminal. If the prompt does not appear when you first enter configuration, press **Return** again.

2. At the + prompt, enter the **f tsf** command to get you to the Thin-Server> prompt.

### **Example:**

```
+ f tsf
Thin-Server>
```



## TSF Monitoring Commands

This section describes the TSF monitoring commands.

Table 63. TSF Monitoring Command Summary

Command	Function
? (Help)	Displays all the commands available for this command level or lists the options for specific commands (if available). See "Getting Help" on page xxxii.
Delete	Deletes a file from Thin Server feature file cache.
Flush	Flushes the Thin Server feature file cache.
List	Displays Thin Server settings and values.
Refresh	Refreshes the cache.
Reset	Resets counters.
Restart	Restarts the Thin Server process.
Set	Changes Thin Server feature settings.
Exit	Returns you to the previous command level. See "Exiting a Lower Level Environment" on page xxxii.

### Delete

Use the **delete** command to remove a file from the Thin Server feature file cache.

**Syntax:**

**delete** *filename*

**filename**

Specifies the name of the file to be remove from the file cache.

**Valid Values:**

**Default Value:** none

**Example:**

```
Thin-Server> delete
Enter filename to delete from the File Cache: /ibm/prod/ns/5494.dat
Are you sure that you want to delete this file? (Y/ [N]): y
File successfully deleted
```

### Flush

Use the **flush** command to flush the TSF memory and hard disk cache space. The **flush** command will erase all cached files. The Thin Server cache will be updated on the next refresh from the Master Server. Network Stations may experience delays until the refresh is completed.

**Syntax:**

**flush**

**Example:**

```
Thin-Server> flush
The FLUSH command will erase all cached files.
The Thin Server cache will be updated on the next refresh
from the Master Server. Network Stations may experience
delays until the refresh is completed.
Are you sure you really want to do this? (Y/ [N]): y
All Thin Server cached files have been flushed
```

## TSF monitoring Commands (Talk 5)

### List

Use the **list** command to display TSF parameter settings.

#### Syntax:

```
list cached-files
      config
      file-access-counters
      file-refresh-counters
      pre-load-list
      tftp-counters
      ts-counters
```

#### Example:

```
Thin-Server> list cached-files
```

```
Cached
File Name      File Size  Time Stamp      Flags  Host File Name
-----
00000026.DAT   2729      04/08/98 13:35:07    RYY   /QIBM/ProdData/OS400/Netstat
ionRmtController/Loadlist.file
00000002.DAT  2049220   09/16/97 08:55:39    RYU   /QIBM/PRODDATA/NETWORKSTATIO
N/KERNEL
              10060   03/04/97 16:12:44    RY-   /QIBM/PRODDATA/NETWORKSTATIO
N/FONTS/PCF/MISC/7X14B.PCF
List is Complete
```

The flags have the following meaning:

- WhereFrom
  - R = RFS Client
  - N = NFS Client
  - - = None
- InTable
  - - = Not in Table
  - u (or m) = About to Update
  - Y = In the Table
- FileState
  - - = Not on Disk
  - D = Dirty
  - A = Update Aborted
  - u = About to Update
  - U = Update in Progress
  - Y = On the Disk and Available

Common combinations of the last two flags (all three flags shown for clarity) are:

- RYY - good file
- RuY - full refresh in progress, this file hasn't been verified yet
- RYU - this file is being updated

#### Example: For RFS

```
Thin-Server> list config
Thin Server Configuration
Thin Server feature mode is:          Disconnected
Thin Server feature state is:        Active, all files up-to-date
Interval to refresh Pre-Load List (#days): 1
```

## TSF monitoring Commands (Talk 5)

```
Time of day (Military) to refresh Pre-Load List: 01:00:00
Memory (KB) currently using for RAM cache: 16384
Maximum memory (KB) configured for RAM cache: 16384
Currently using Hard File?: Yes
Hard File storage defined for Thin Server: 817664
Hard File storage being used for Thin Server: 27328
Number of Files Cached: 82
Master Server IP address: 192.9.225.21
Secondary Master Server IP address: 192.9.225.20
Master Server Retry Limit: 10
Master Server Selection: primary
TFTP Packet Timeout Value: 5
TFTP Max Retries: 1
TFTP Max Segment Size: 8192
```

```
Thin Server Sync Protocol: RFS
Name of Pre-Load List file:
/QIBM/ProdData/OS400/NetstationRmtController/Loadlist.file
```

Thin Server>

### Example: For NFS

Thin-Server> **list config**

```
Thin Server Configuration
Thin Server feature is: Enabled
Thin Server Feature state is: Active, initializing file structure
Interval to refresh Pre-Load List (#days): 1
Time of day (Military) to refresh Pre-Load List: 01:00:00
Memory (KB) currently using for RAM cache: 25600
Maximum memory (KB) configured for RAM cache: 25600
Currently using Hard File?: Yes
Hard File storage defined for Thin Server: 915424
Hard File storage being used for Thin Server: 27328
Number of Files Cached: 82
Master Server IP address: 192.9.225.21
Secondary Master Server IP address: 192.9.225.20
Master Server Retry Limit: 10
Master Server Selection: primary
TFTP Packet Timeout Value: 5
TFTP Max Retries: 1
TFTP Max Segment Size: 8192

Thin Server Sync Protocol: NFS
Include Directory List Follows:
```

Include

all

Subdirs? Directory Names

```
-----
N /usr/netstation
Y /usr/netstation/mods
Y /usr/netstation/nls
Y /usr/netstation/fonts
Y /usr/netstation/java
Y /usr/netstation/keyboards
Y /usr/netstation/proms
Y /usr/netstation/X11
Y /usr/netstation/configs
Y /usr/netstation/SysDef
Y /usr/netstation/zoneinfo
```

Thin Server>

### Example:

Thin-Server> **list file-access-counters**

Disk Statistics/Counters:

## TSF monitoring Commands (Talk 5)

Number of files currently open:	20
Number of Total File Opens:	23
Number of Open Fails when File is Locked:	1
Number of Read misses - Version Mismatch:	4
Number of Read misses - File Not Present:	3
Number of Write misses - Hard File Full:	4

### Example:

Thin-Server> **list file-refresh-counters**

```
File Refresh Statistics/Counters
Last Successful refresh Master Server IP address: 192.9.225.20
Current refresh Master Server IP address: 192.9.225.21
Number of Files Updated during last refresh: 0
Number of Update Failures during last refresh: 0
Number of Refreshes: 0
Number of Refresh Failures: 1
Number of Refreshes - Primary Master Server: 0
Number of Refresh Failures - Primary Server: 0
Number of Refreshes - Secondary Master Server: 0
Number of Refresh Failures - Secondary Server: 0
Number of Files Refreshed: 249
Date/Time of Last File Update: 02/17/1999 01:00:36
Date/Time of Last File Download: 02/16/1999 15:57:05
```

Thin Server>

### Example:

```
Thin-Server> list pre-load-list
<display of pre-load list raw file>
List of Pre-Load List File is Complete
```

### Example:

Thin-Server> **list tftp-counters**

```
TFTP Server Statistics/Counters
Relay to Master File Server: Available
Number of Total TFTP Requests: 3
Number of Current TFTP Requests: 2
Number of Files Served: 22
Number of Files Served by Master Server: 22
Number of Files Served by Primary Master Server: 22
Number of Files Served by Secondary Master Server: 0
```

Thin Server>

### Example: For RFS

Thin-Server> **list ts-counters**

```
Thin Server Statistics/Counters
Relay to Master File Server: Available
Number of Total RFS Clients: 0
Number of Current RFS Clients: 0
Number of Files Served: 0
Number of Files Served by Master Server: 0
Number of NS Port Mapper socket accepts: 0
Number of NS Port Mapper sockets currently active/open: 0
Number of NS Server socket accepts: 0
Number of NS 8473 sockets currently active/open: 0
Number of NS Login sock accepts: 0
Number of NS 8476 sockets currently active/open: 0
Number of RFS writes to a Thin Server cached file: 0
```

Thin Server>

**Example: For NFS**

```
Thin-Server> list ts-counters

Thin Server Statistics/Counters
  Number of NFS Server Reads:                13
  Number of NFS Server Read Directories:     8
  Number of Unsupported NFS Requests:        2
  Number of total NFS Mounts:                22
  Number of current NFS Mounts:              7
  Number of total NFS clients:               15
  Number of current NFS Clients:             4
```

## Refresh

Use the **refresh** command to force a refresh of the cache.

**Syntax:**

**refresh**

**Example:**

```
Thin-Server> refresh

Force a refresh of the cache (Y/N) [N]? y

Thin Server cache has been refreshed
```

## Reset

Use the **reset** command to dynamically reset counters.

**Syntax:**

**reset**                                    all  
     file-access-counters  
     file-refresh  
     tftp-counters  
     ts-counters

**Example:**

```
Thin-Server> reset all

All Thin Server feature counters have been reset
```

## Restart

Use the **restart** command to restart the TSF process.

**Syntax:**

**restart**

**Example:**

```
Thin-Server> restart

Restart Thin Server? (Y/ [N]): y

Thin Server has been restarted
```

## TSF monitoring Commands (Talk 5)

### Set

Use the **set** command to set the TSF caching mode.

#### Syntax:

```
set mode
```

**mode** Specifies the mode of the TSF. See “Set” on page 572.

#### Valid Values:

- enable
- disable
- passthru
- disconnected

#### Example:

```
Thin-Server> set mode disconnected
```

```
Thin Server caching is now disconnected
```

---

## TSF Dynamic Reconfiguration Support

This section describes dynamic reconfiguration (DR) as it affects Talk 6 and Talk 5 commands.

### CONFIG (Talk 6) Delete Interface

TSF does not support the CONFIG (Talk 6) **delete interface** command.

### GWCON (Talk 5) Activate Interface

The GWCON (Talk 5) **activate interface** command is not applicable for TSF. Activating an interface does not affect the Thin Server directly; however, it may impact the connectivity to the client or master file server.

### GWCON (Talk 5) Reset Interface

The GWCON (Talk 5) **reset interface** command is not applicable for TSF. Resetting an interface does not affect the Thin Server directly; however, it may impact the connectivity to the client or master file server.

### GWCON (Talk 5) Component Reset Commands

Thin Server feature supports the following TSF-specific GWCON (Talk 5) **reset** commands:

#### GWCON, Feature TSF, Restart Command

##### Description:

Restarts the Thin Server.

##### Network Effect:

Thin client cannot access the Thin Server for files during the restart.

##### Limitations:

Modifying the type of master file server (rfs versus nfs) is not recommended. Doing so will affect the amount of memory available to be used as the file cache and the restart may fail if insufficient memory is available.

## TSF monitoring Commands (Talk 5)

All TSF configuration changes are automatically activated except the following:

<b>Commands whose changes are not activated by the GWCON, feature tsf, restart command</b>
--

CONFIG, feature tsf, set memory-cache
---------------------------------------

## GWCON (Talk 5) Temporary Change Commands

TSF supports the following GWCON commands that temporarily change the operational state of the device. These changes are lost whenever the device is reloaded, restarted, or you execute any dynamically reconfigurable command.

<b>Commands</b>
-----------------

GWCON, feature tsf, set mode
------------------------------

<b>Note:</b> The mode of the thin server feature is changed.
--

## Non-Dynamically Reconfigurable Commands

The following table describes the TSF configuration commands that cannot be dynamically changed. To activate these commands, you need to reload or restart the device.

<b>Commands</b>
-----------------

CONFIG, feature tsf, set memory-cache
---------------------------------------

<b>Note:</b> If you are increasing the amount of memory cache specified, then a router restart or reload is required.
---

CONFIG, feature tsf, set mode
-------------------------------

<b>Note:</b> If the Thin Server mode was disabled when the router was restarted or reloaded, then a router restart or reload is required after setting the Thin Server mode to enabled. The Thin Server mode defaults to disabled when the Thin Server package is initially loaded.
---

## TSF monitoring Commands (Talk 5)



---

## Chapter 36. Configuring and Monitoring VCRM

Virtual Circuit Resource Manager (VCRM) is a feature that supports Resource ReSerVation Protocol (RSVP), which is described in “Using RSVP” and “Configuring and Monitoring RSVP” in the *Protocol Configuration and Monitoring Reference Volume 1*. Based upon the reservation request from RSVP, VCRM creates the connection for the data flow over the physical interface. To do this, VCRM must first determine whether enough bandwidth exists to accommodate the reservation.

**Note:** If you are using WAN interfaces such as frame relay or X.25, you need to set the line speed so that VCRM knows how much bandwidth is available. The procedure for setting the line speed is described in the Frame Relay and X.25 interface configuration and monitoring chapters of the *Access Integration Services Software User's Guide*.

If the interface is a PPP link, LAN, or WAN, VCRM uses software queuing of the QoS and best-effort packets to prioritize the packets on the outbound link.

This chapter includes the following sections:

- “Accessing the VCRM Configuration Environment”
- “Accessing the VCRM Monitoring Environment”
- “VCRM Monitoring Commands” on page 584

---

### Accessing the VCRM Configuration Environment

To access the VCRM configuration environment, enter the following command at the Config> prompt:

```
Config> feature vcrm
VC & Resource Management config console
--Currently no configurable objects.
Config>
```

The purpose of the message displayed is to indicate that VCRM cannot be separately configured. Enabling RSVP enables VCRM, which obtains its parameters from the RSVP configuration.

---

### Accessing the VCRM Monitoring Environment

To access the VCRM monitoring environment, type

```
* t 5
```

Then, enter the following command at the + prompt:

```
+ feature VCRM
VCRM console
VCRM Console>
```

The VCRM Console> prompt appears.

### VCRM Monitoring Commands

This section describes the VCRM monitoring commands. Enter these commands at the VCRM Console> prompt.

Table 64. VCRM Monitoring Commands

Command	Function
? (Help)	Displays all the commands available for this command level or lists the options for specific commands (if available). See "Getting Help" on page xxxii.
Clear	Resets the queue statistics.
Queue	Shows software queuing statistics.
Exit	Returns you to the previous command level. See "Exiting a Lower Level Environment" on page xxxii.

#### Clear

Use the **clear** command to reset the software queue statistics.

**Syntax:**

**clear**

See the **queue** command for an example of the **clear** command.

#### Queue

Use the **queue** command to show the software queuing of the traffic flows .

**Syntax:**

**queue**

The following list defines the terms used in displaying software queues:

**Quota** Amount of bandwidth reserved. Originally, best-effort (B.E.) has all the quotas. When a reservation is made, the reserved bandwidth (b/w) is shifted from the B.E. quota to the QoS quota.

**Max-q** Maximum queue length, stated in packets.

**Curr-q**

Current queue length, stated in packets.

**In quota**

Packets or kilobytes sent within the allocated bandwidth.

**Outside quota**

Packets or kilobytes sent outside of the allocated bandwidth, when idle bandwidth was available.

**Packets/bytes dropped**

Packets or bytes dropped by software queueing.

**DLC packets/bytes dropped**

Packets or bytes dropped by DLC after the packets have gone through the software queue.

**Example:**

```
*t 5
+feature vcrm
```

## Monitoring VCRM (Talk 5)

```

VCRM console
VCRM Console>?
CLEAR
QUEUE
EXIT
VCRM Console>queue
Flow-control Queues at sys-clock 346781 Second:
-----
Intf   B.E. Quota:      10000 Kbps      QoS Quota:      0      Kbps
0/Eth  B.E. Max-q      0      QoS Max-q      0
      B.E. curr-q   0      QoS curr-q     0
      B.E. pkts/Kbytes sent:      QoS pkts/Kbytes sent:
      in quota:    54169/ 3926    in quota:      0/      0
      outside quota: 0/      0      outside quota: 0/      0
      B.E. pkts/bytes dropped: 0/0    QoS pkts/bytes dropped: 0/0
      DLC pkts/bytes dropped: B.E.: 0/0    QoS: 0/0
Intf   B.E. Quota:      2048 Kbps      QoS Quota:      0      Kbps
2/PPP  B.E. Max-q      0      QoS Max-q      0
      B.E. curr-q   0      QoS curr-q     0
      B.E. pkts/Kbytes sent:      QoS pkts/Kbytes sent:
      in quota:    62/      6      in quota:      0/      0
      outside quota: 0/      0      outside quota: 0/      0
      B.E. pkts/bytes dropped: 0/0    QoS pkts/bytes dropped: 0/0
      DLC pkts/bytes dropped: B.E.: 0/0    QoS: 0/0
Intf   B.E. Quota:      2032 Kbps      QoS Quota:      16     Kbps
3/FR   B.E. Max-q      1      QoS Max-q      1
      B.E. curr-q   0      QoS curr-q     0
      B.E. pkts/Kbytes sent:      QoS pkts/Kbytes sent:
      in quota:    53160/ 4920    in quota:      346596/ 31886
      outside quota: 0/      0      outside quota: 0/      0
      B.E. pkts/bytes dropped: 0/0    QoS pkts/bytes dropped: 0/0
      DLC pkts/bytes dropped: B.E.: 0/0    QoS: 0/0
Intf   B.E. Quota:      2048 Kbps      QoS Quota:      0      Kbps
4/PPP  B.E. Max-q      1      QoS Max-q      1
      B.E. curr-q   0      QoS curr-q     0
      B.E. pkts/Kbytes sent:      QoS pkts/Kbytes sent:
      in quota:    66/      6      in quota:      109/      1
      outside quota: 0/      0      outside quota: 0/
      B.E. pkts/bytes dropped: 0/0    QoS pkts/bytes dropped: 0/0
      DLC pkts/bytes dropped: B.E.: 0/0    QoS: 0/0

Max total queue length=1; current total length=0
VCRM Console>clear
Flow-control Queues cleared at sys-clock 346786 Second:
-----
VCRM Console>

```

## Monitoring VCRM (Talk 5)

---

## Chapter 37. Using the Voice Feature

This chapter describes the 2212 voice capabilities, supported adapters, and configuration options.

This chapter includes the following sections:

- “Voice Adapter Overview”
- “Voice Features”
- “Configuration Concepts”
- “Voice over Frame Relay Configuration Information” on page 588

---

### Voice Adapter Overview

The 2212 can support a maximum of four voice adapters. Each adapter has two voice interfaces. The following adapters are supported:

- 2-port Analog FXS Voice/Fax CPCI
- 2-port Analog FXO Voice/Fax CPCI
- 2-port Analog E&M Voice/Fax CPCI

These adapters allow connectivity to private branch exchange (PBX), a telephone, or a key system. The 2212 supports Voice over Frame Relay (VoFR) with any of these adapters.

---

### Voice Features

The 2212 with a voice adapter supports Voice over Frame Relay. With VoFR, you can configure the 2212 to communicate with an IBM 9783, another router (router-to-router), or between the voice interfaces on the same 2212 (Local Call Routing). With VoFR, you can also setup the 2212 to forward voice packets - this does not require a voice adapter. For information on voice forwarding, refer to the section titled “Voice Forwarding Over Frame Relay” in the “Using Frame Relay Interfaces” chapter in the *MRS Software User's Guide*

---

### Configuration Concepts

There are 4 main groups of voice parameters to configure voice on the 2212.

**Voice Feature parameters** These parameters are defined once, and apply to all voice interfaces on the 2212. Examples include tone and timer settings, and telco output rules.

**Voice Interface parameters** These parameters are unique for each voice interface. These parameters include: Fax Rate, Vocoder Suite, Tx and Rx gain values, and etc.

**Voice over Frame Relay parameters** These parameters are used to configure Voice over Frame Relay connections (including router-to-router, IBM 9783, and Local Call Routing connections). Dial rules, call processing plans, and so on, are defined here.

For Voice over Frame Relay configurations (for router-to-router, and IBM 9783 connections only), or for VoIP configurations that include communicating with an

## Using the Voice Feature

IBM 9783, you will need to configure Frame Relay over an interface. See the chapter “Configuring and Monitoring Frame Relay Interfaces” in the *AIS Software User’s Guide* for more information.

---

## Voice over Frame Relay Configuration Information

In order for the 2212 to communicate with Voice over Frame Relay, you must configure the following:

- Call processing rules
- Enable Frame Relay on the interface
- Telco output rule (if connecting to a PBX or key system)

For each voice interface, you can define up to eight call processing rules. Each rule contains a set of connection parameters that determine how a connection is established. For remote connections (that is, not Local Call Routing), the call processing rule contains the following information:

- Processing DLCI (16 to 1007)
- Payload DLCI (16 to 1007)
- Processing subchannel (4 to 254)
- Payload subchannel (4 to 254)
- Dial digit matching rule number (1 to 64)
- Network output rule number (1 to 64)

**Note:** The payload and processing parameters defined for a voice interface should correspond to the payload and processing parameters defined for IBM 9783s that are setup to communicate with that voice interface (if IBM 9783s are used in the network).

For Local Call Routing, the call processing rule contains:

- Dial digit matching rule number (1 to 64)
- Network output rule number (1 to 64)

The dial digit matching rule lets you specify the range of acceptable digits at each position in a dial digit sequence. You can specify multi-digit wildcards as well as a sequence that causes an immediate connection during an “off-hook” condition. You can define a pool of up to 64 rules and specify a dial digit rule in each call processing rule.

The network output rule lets you specify how the destination number should appear in the call setup Frame Relay packet. This rule consists of a combination of destination number digits and constants.

Telco output rules determine how dial digits are transmitted on the 2212 interface. Each telco output rule is comprised of a combination of destination dial digits, source number digits, constants, and pauses. A Telco output rule must be configured to outpulse for FXO and E&M interfaces. For each 2212, you can define up to eight telco output rules.

When a 2212 voice interface originates a call, the destination number is compared to that interface’s dial digit matching rules. These rules are defined in the call processing rules for that interface. When a match is found, the DLCI and subchannel (for router-to-router and IBM 9783 connections) or the local number, (for

local call routing) from the matching rule determines the destination node. If the destination number needs to be modified, the network output rule determines how it should be modified.

When a 2212 receives a call, the DLCI and subchannel, for router-to-router and IBM 9783 connections, or the local number, for local call routing, determine which voice interface is to receive the call. Each voice interface accepts calls from any DLCI and subchannel pair that is defined in one of its call processing rules. The destination voice interface's telco output rule is used with the destination number to generate the dial digit outputpulse sequence, if one is required.

## Communicating with an IBM 9783

Figure 53 shows a network where two 2212s are connected to an IBM 9783. Defining this voice network is a two-step configuration process. First, you need to set the IBM 9783 up to communicate with the 2212 voice interface. Then, define the 2212 voice interface with the corresponding information.

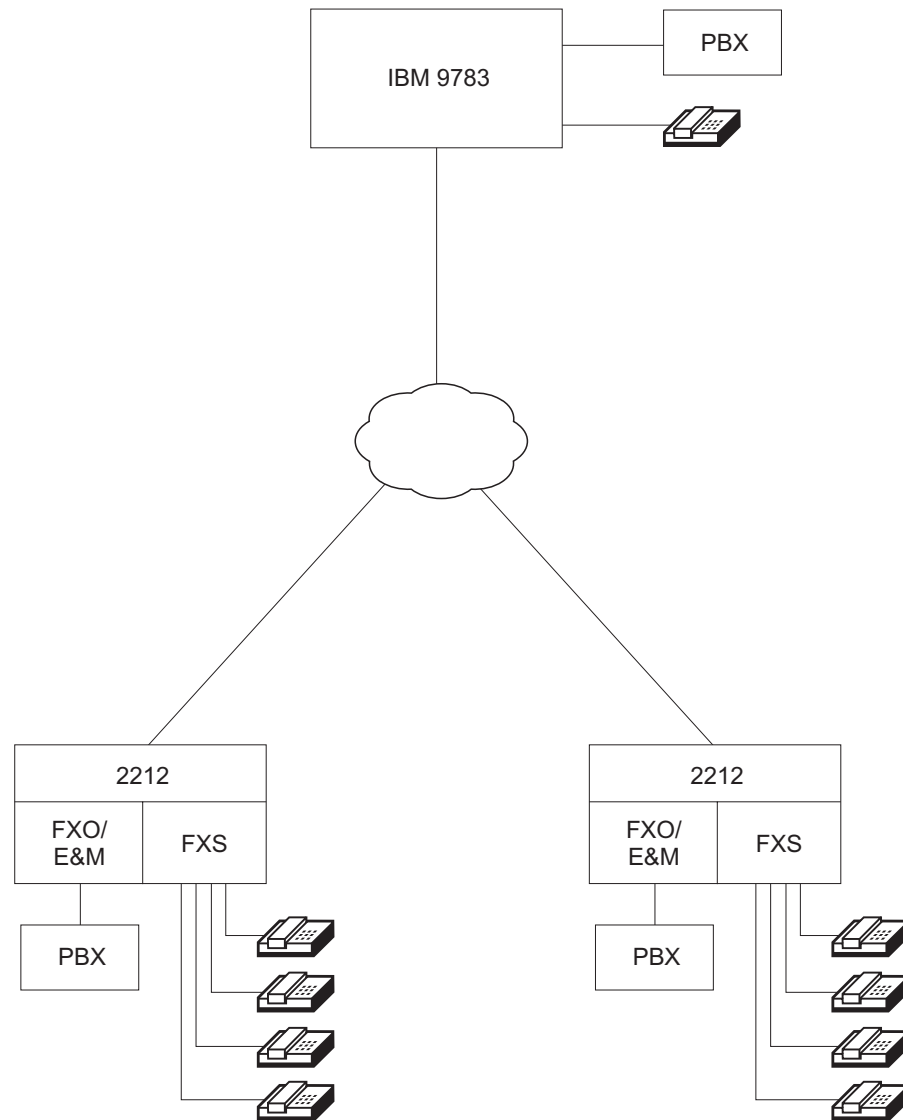

Figure 53. IBM 9783 to 2212 Voice Interfaces Communication

## Using the Voice Feature

### Configuring the IBM 9783 to Communicate with a 2212

To configure the IBM 9783 to communicate with a 2212 voice interface, you need to define a set of parameters called a dialing plan. An IBM 9783 dialing plan contains the following information:

- Circuit groups
- Circuit descriptors

Figure 54 shows the routing information needed for communication between voice interfaces on 2212A and 2212B.

IBM 9783 0.0.0.1 Circuit Group (Dialing Plan)

Circuit Group #	Circuit (Description)	DLCI	Subchannel
1	Process 5	16	4
		16	5
2	Process 5	17	4
		17	5
3	Process 7	17	6
		17	7

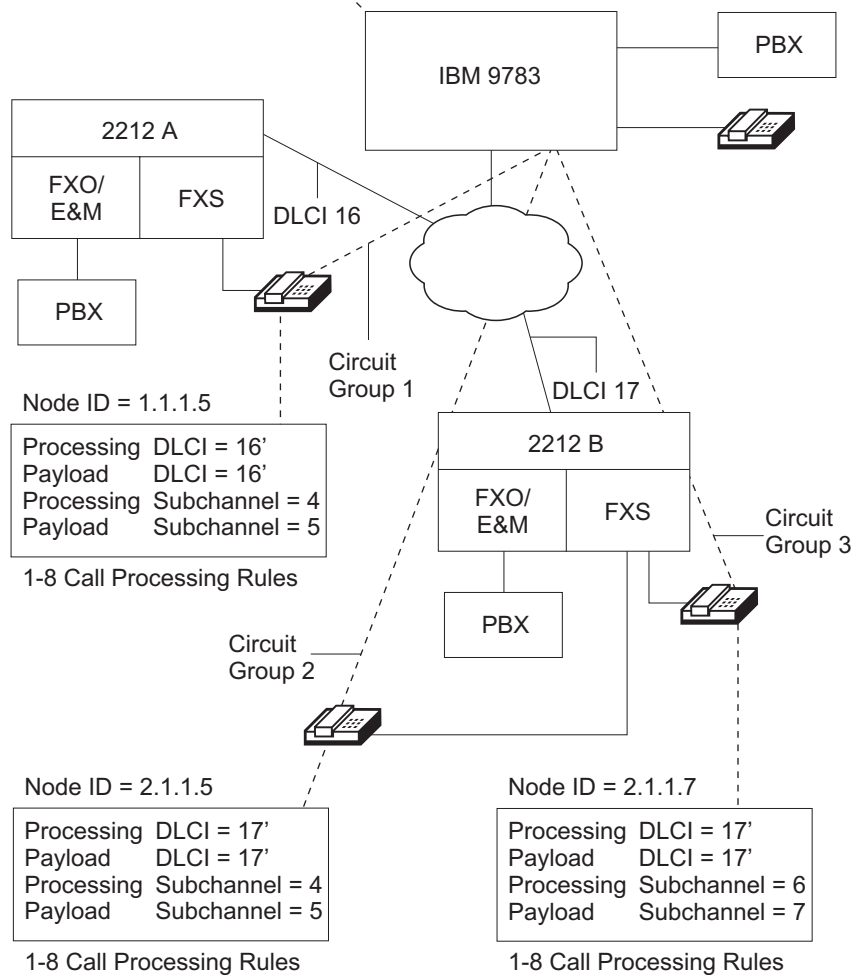

Figure 54. Configuring Voice Port Call Processing Information



An IBM 9783 circuit group defines a *virtual voice network trunk* between an IBM 9783 and a remote node. Although an IBM 9783-IBM 9783 circuit group can contain many individual circuits, an IBM 9783-2212 voice interface circuit group only contains one (PVC) circuit. The circuit group connects to the remote node (IBM 9783 or 2212 voice interface). In Figure 54 on page 590; Circuit Group 1 connects to the 2212A voice interface having a node ID of 1.1.1.5. Circuit Group 2 connects to the 2212B voice interface having a node ID of 2.1.1.5. Circuit Group 3 connects to the 2212B voice interface having a node ID of 2.1.1.7. Each 2212 voice interface, even interfaces on the same 2212, must have a unique node ID. Therefore, a unique circuit group must be defined to the IBM 9783 for each 2212 voice interface.

An IBM 9783 circuit descriptor defines the individual circuits within each circuit group. For an IBM 9783-IBM 9783 circuit group, you can have multiple circuit descriptors; one for each circuit in the group. Because an IBM 9783-2212 voice interface circuit group only contains one circuit, an IBM 9783-2212 voice interface circuit group only contains one circuit descriptor.

Circuit descriptors contain both processing circuit and payload circuit information. The processing circuit is used to transfer packets required to establish the call and terminate the call. These packets are Nuera's proprietary CALL SETUP, CONNECT, ANSWER, and RELEASE packets. The payload circuit is used to transfer packets containing the actual compressed voice data.

In Figure 54 on page 590, the IBM 9783 has a dialing plan that contains three circuit groups, one for each 2212 voice interface that it needs to connect to. When an IBM 9783 receives a request to establish communication with a specific node ID, it uses the circuit group to locate the target device. An IBM 9783 circuit group contains the following information:

- Circuit group number
- Connect-to-node (node it is connecting to)
- Circuit descriptors (process and payload)
  - DLCI (16-991)
  - Subchannels (process and payload)

**Note:** When defining a circuit descriptor for an IBM 9783-2212 voice interface circuit, the circuit descriptor and the payload subchannel number must match. The minimum subchannel value that you can specify is 4. All circuit groups between an IBM 9783 and a 2212 can use the same DLCI.

**Configuring a Dialing Plan:** A dialing plan for an IBM 9783 consists of from 1 to 4 translation rules. These rules control how devices connect and communicate with the IBM 9783. Each translation rule consists of a number of ordered cases (from 1 to 100). Each IBM 9783 circuit group is associated with a specific translation rule. Each translation rule is composed of the following elements:

<b>Source match rule</b>	A dial digit matching pattern for a source number.
<b>Destination match rule</b>	A dial digit matching pattern for a destination number.
<b>Route rule</b>	A list of circuit groups, subsets of circuit groups, or local ports.
<b>Source output rule</b>	A rule for translating the source number during call setup.

## Using the Voice Feature

**Destination output rule** A rule for translating the destination number during call setup or during data transmission.

During call setup, the source and destination numbers are compared to the corresponding match rules in each translation rule case. The comparisons are made in ascending order until a match is found. When a match is found, the route rule in the matched case routes the call. The output rule in the matched case modifies the call setup information or generates dial digits.

### Configuring the 2212 Voice Interface to Communicate with the IBM 9783

To configure a 2212 voice interface to communicate with an IBM 9783, you need to define the following information:

- Call processing rule - Up to eight rules for each voice interface.
- Node ID - One for each voice interface.

## Network Configurations without an IBM 9783

If you require only limited network accessibility, you can establish communication between two voice interfaces without using an IBM 9783 by applying the following methods:

- Communicating between voice interfaces on different 2212s (router-to-router).
- Communicating between voice interfaces on the same 2212 (local call routing).

### Router-to-Router Configurations

By defining corresponding call processing rules for each voice interface, calls can be made between two voice interfaces in different 2212s without using an IBM 9783. Each of these rules must specify the same payload and call processing subchannels, as well as corresponding payload and call processing DLCIs. When communicating without an IBM 9783, the node ID field is not used. If a voice interface connects to a PBX or key system, a telco output rule must be configured for the voice interface.

**Note:** Without connecting to an IBM 9783, each voice interface can connect to a maximum of eight remote voice interfaces. If you enable local call routing on a voice interface, that interface can only connect to seven remote voice interfaces.

### Local Call Routing

Calls can be made between two voice interfaces on the same 2212 without using an IBM 9783. You can do this by configuring one of the eight call processing rules on each interface for local call routing. Local call routing compares the destination number to the local number configured for each voice interface that has a local call rule defined. You can specify the number of leading digits to be compared in each interface's local number.

The network output rule, specified in a local call rule, must specify enough destination number digits to correctly route the call.

Because the source voice interface and the destination voice interface are within the same 2212, a local routing call rule does not contain DLCI information or subchannel information.

---

## Chapter 38. Configuring and Monitoring the Voice Feature

This chapter describes how to use the voice configuration and monitoring commands. It includes the following sections:

- “Accessing the Voice Feature Commands”
- “Voice Feature Commands”
- “Accessing the Voice Interface Commands” on page 599
- “Voice Interface Commands” on page 600
- “Accessing the Voice over Frame Relay (VoFR) Commands” on page 604
- “Voice over Frame Relay (VoFR) Commands” on page 605
- “Accessing the Voice Interface Monitoring Environment” on page 612
- “Voice Interface Monitoring Commands” on page 612
- “Voice Feature Dynamic Reconfiguration Support” on page 616
- “Voice Interfaces Dynamic Reconfiguration Support” on page 616

---

### Accessing the Voice Feature Commands

Use the following procedure to access the voice feature configuration process.

1. At the OPCON prompt, enter **talk 6**. (For more detail on this command, refer to *The OPCON Process and Commands* in the Access Integration Services Software User’s Guide.) For example:

```
* talk 6
Config>
```

After you enter the **talk 6** command, the CONFIG prompt (Config>) displays on the command line. If the prompt does not appear when you first enter configuration, press **Return** again.

2. At the CONFIG prompt, enter the **feat voice** command to get to the Voice Config> prompt.

---

### Voice Feature Commands

This section describes the voice feature parameters, and the commands used to configure them.

Table 65. Voice Feature Command Summary

Command	Function
? (Help)	Displays all the commands available for this command level or lists the options for specific commands (if available). See “Getting Help” on page xxxii.
Add	Adds a telco-output rule.
Delete	Deletes a telco-output rule.
List	Lists the timers and tones that apply to all voice interfaces and the telco-output rules.
Modify	Updates a telco-output rule.
Set	Sets the timers and tones that apply to all voice interfaces.
VoFR	Accesses the Voice over Frame Relay configuration commands.
Exit	Returns you to the previous command level. See “Exiting a Lower Level Environment” on page xxxii.



For an explanation of the telco-output rule, see “Add” on page 594.

## List

Use the **list** command to display the timers and tones that apply to all voice interfaces, and the telco-output rules.

**Syntax:**

```
list telco-output-rule ...
      timers
      tones
```

**telco-output-rule**

Lists the specified telco output rule. If a rule number is not specified, the Rule # prompt is displayed.

**timers** Lists all the delays and timeouts (in ms). See page 595 for a description of the parameters.

**Example:**

```
Voice config>list timers
Seize Detect Delay      :50 ms   First Digit Timeout    :10000 ms
Answer Detect Delay     :10 ms   Inter Digit Timeout    :5000 ms
Discon Detect Delay     :200 ms  Start Dial Delay       :500 ms
Glare Detect Delay      :500 ms  Ring No Answer Timeout :30000 ms
Wink Detect Timeout    :2000 ms Ring on Detect Timeout  :400 ms
Wink Start Delay       :50 ms   Ring Off Detect Timeout :6000 ms
Wink Duration          :200 ms   Warble Timeout         :10000 ms
```

**tones** Lists all the tones associated with this voice feature. See page 597 for a description of the parameters.

**Example:**

```
Voice config>list tones
Tone      On1  Off1  On2  Off2  Freq1 Freq2  Level1 Level2
          ms   ms   ms   ms   Hz    Hz    dB    dB
Dial      0    0    0    0    350   440   -16   -16
Ring Back 2000  4000 2000  4000 440   480   -22   -22
Busy      500   500   500   500   480   620   -20   -20
Fast Busy 300    300   300   300   480   620   -16   -16
Warble    100    100   100   100   1400  2060  -16   -16
Dtmf      100    100   100   100   1400  2060  -7    -7
```

## Modify

Use the **modify** command to update telco-output rules for the voice feature.

**Syntax:**

```
modify telco-output-rule
```

For an explanation of the telco-output-rule, see “Add” on page 594.

## Set

Use the **set** command to specify the various delay and timeout values.

**Syntax:**

```
set timer . . .
      tone . . .
```

**timer** Use the **set timer** command to set the following timer parameters.

## Voice Feature Commands (Talk 6)

### **answer-detect-delay**

Specifies the time (in ms) before an answer signal is recognized.

**Valid Values:** 0 to 500 ms

**Default Value:** 10 ms

### **disconnect-detect-delay**

Specifies the time (in ms) before a disconnect signal is recognized.

**Valid Values:** 0 to 500 ms

**Default Value:** 200 ms

### **first-digit-timeout**

Specifies the time (in ms) during which the first digit must be received.

**Valid Values:** 0 to 10 000 ms

**Default Value:** 10 000 ms

### **glare-detect-delay**

Specifies the time (in ms) before an interface can seize a channel.

**Valid Values:** 0 to 500 ms

**Default Value:** 500 ms

### **inter-digit-timeout**

Specifies the time (in ms) during which a digit must be received *after* the first digit is received.

**Valid Values:** 0 to 10 000 ms

**Default Value:** 5000 ms

### **ring-no-answer-timeout**

Specifies the time (in ms) that a voice channel rings an FXO interface while waiting for an answer before abandoning the call.

**Valid Values:** 0 to 64 000 ms

**Default Value:** 30 000 ms

### **ring-off-detect-timeout**

Specifies the time (in ms) of an absence of ringing at an FXO interface before the server determines that the ringing has stopped.

**Valid Values:** 0 to 64 000 ms

**Default Value:** 6000 ms

### **ring-on-detect-timeout**

Specifies the time (in ms) of the presence of ringing at an FXO interface before the ringing is recognized.

**Valid Values:** 0 to 64 000 ms

**Default Value:** 400 ms

### **start-dial-delay**

Specifies the time (in ms) after receipt of a dial signal but before digits are transmitted.

**Valid Values:** 0 to 64 000 ms

**Default Value:** 500 ms

### **seize-detect-delay**

Specifies the time (in ms) before a seize signal is recognized.

**Valid Values:** 0 to 500 ms

**Default Value:** 50 ms

### **warble-timeout**

Specifies the time (in ms) of silence needed after a disconnect before a warble signal is generated.

**Valid Values:** 0 to 64 000 ms

**Default Value:** 10 000 ms

### **wink-detect-timeout**

Specifies the time (in ms) after which, if a wink is not received, a call is ended.

**Valid Values:** 0 to 64 000 ms

**Default Value:** 2000 ms

### **wink-duration**

Specifies the duration time (in ms) of the wink signal.

**Valid Values:** 0 to 1000 ms

**Default Value:** 200 ms

### **wink-start-delay**

Specifies the time (in ms) after receipt of an incoming seize signal, that a wink signal is generated.

**Valid Values:** 0 to 64 000 ms

**Default Value:** 50 ms

**tone** Use the **set tone** command to set the following tone parameters.

**busy** Specifies the characteristics of up to two frequencies used to generate the busy signal. When the set tone busy command is entered, you are queried for the following information:

**on1** Specifies the time (in ms) that *freq1* is "on" (active). If zero is specified, the associated tone is always on resulting in a continuous tone.

**Valid Values:** 0 to 32 767 ms

**Default Value:** 500

**off1** Specifies the time (in ms) that *freq1* is "off" (inactive). If zero is specified, the associated tone is always on resulting in a continuous tone.

**Valid Values:** 0 to 32 767 ms

**Default Value:** 500

**on2** Specifies the time (in ms) that *freq2* is "on" (active). If zero is specified, the associated tone is always on resulting in a continuous tone.

**Valid Values:** 0 to 32 767 ms

**Default Value:** 500

## Voice Feature Commands (Talk 6)

- off2** Specifies the time (in ms) that *freq2* is "off" (inactive). If zero is specified, the associated tone is always on resulting in a continuous tone.  
**Valid Values:** 0 to 32 767 ms  
**Default Value:** 500
- freq1** Specifies the frequency (in hertz) of the first tone in the busy signal.  
**Valid Values:** 300 to 3000 hertz  
**Default Value:** 480 hertz
- freq2** Specifies the frequency (in hertz) of the second tone in the busy signal.  
**Valid Values:** 300 to 3000 hertz  
**Default Value:** 620 hertz
- level1** Specifies the dB gain level of *freq1* in increments of 0.5 dB.  
**Valid Values:** -9 dB to -22 dB  
**Default Value:** -20 dB
- level2** Specifies the dB gain level of *freq2* in increments of 0.5 dB.  
**Valid Values:** -9 dB to -22 dB  
**Default Value:** -20 dB
- dial** Specifies the characteristics of up to two frequencies used to generate a dial tone. When the **set tone dial** command is entered, you are queried for *on1*, *off1*, *on2*, *off2*, *freq1*, *freq2*, *level1*, and *level2*. See page 597 for a description of the parameters. See footnote <sup>1</sup> for more information.
- dtmf** Specifies the characteristics of the dual-tone multifrequency (DTMF) signal. When the **set tone dtmf** command is entered you are queried for the following information:
- ontime**  
Specifies the "on time" (in ms) of the DTMF. If zero is specified, no DTMF signal is generated. Normally you should not specify an *ontime* of less than 40 ms. This results in a signal with 12.5 tones/second.  
**Valid Values:** 0 to 32767 ms  
**Default Value:** 100 ms
- offtime**  
Specifies the "off time" (in ms) of the DTMF. If zero is specified, no DTMF signal is generated.  
**Valid Values:** 0 to 32767 ms  
**Default Value:** 100 ms

---

1. The default values for dial, fast busy, ring-back, and warble are not the same as those used for busy. See dial on page 598, fast busy on page 599, ring-back on page 599, and warble on page 599 for additional information.



## Voice Feature Commands (Talk 6)

### level low tone

Specifies the dB gain level of the low DTMF signal in increments of 0.5 dB.

**Valid Values:** –7 dB to –31 dB

**Default Value:** –7 dB

### level high tone

Specifies the dB gain level of the high DTMF signal in increments of 0.5 dB.

**Valid Values:** –7 dB to –31 dB

**Default Value:** –7 dB

### fast busy

Specifies the characteristics of up to two frequencies used to generate the fast busy signal. When the **set tone fast busy** command, is entered you are queried for *on1*, *off1*, *on2*, *off2*, *freq1*, *freq2*, *level1*, and *level2*. See page 597 for a description of the parameters. See footnote <sup>1</sup> for more information.

### ring-back

Specifies the characteristics of up to two frequencies used to generate a ring-back. When the **set tone ring-back** command is entered, you are queried for *on1*, *off1*, *on2*, *off2*, *freq1*, *freq2*, *level1*, and *level2*. See page 597 for a description of the parameters. See footnote<sup>1</sup> for more information.

### warble

Specifies the characteristics of up to two frequencies used to generate a dial tone. When the **set tone warble** command is entered, you are queried for *on1*, *off1*, *on2*, *off2*, *freq1*, *freq2*, *level1*, and *level2*. See page 597 for a description of the parameters. See footnote<sup>1</sup> for more information.

## VoFR

See “Accessing the Voice over Frame Relay (VoFR) Commands” on page 604 for the details of this command.

---

## Accessing the Voice Interface Commands

Use the following procedure to access the voice interface configuration process.

1. At the OPCON prompt, enter **talk 6**. (For more detail on this command, refer to “The OPCON Process and Commands” in the *Access Integration Services Software User’s Guide*.)

2. For example:

```
* talk 6
Config>
```

After you enter the **talk 6** command, the CONFIG prompt (Config>) displays on the command line. If the prompt does not appear when you first enter configuration, press **Return** again.

3. At the CONFIG> prompt, enter **net x** where x is the voice interface number.

### Voice Interface Commands

This section describes the voice interface parameters, and the commands used to configure them.

Table 66. Voice Interface Command Summary

Command	Function
? (Help)	Displays all the commands available for this command level or lists the options for specific commands (if available). See “Getting Help” on page xxxii.
List	Lists various voice interface settings.
Set	Sets various voice interface parameters.
Exit	Returns you to the previous command level. See “Exiting a Lower Level Environment” on page xxxii.

### List

Use the **list** command to display the current settings of a voice interface.

#### Syntax:

**list**

For example, to list the current configuration of the voice interface, enter:

#### Example:

```
Voice 8 config>list
NodeID: 1.2.3.4
Local Phone Number:1234567
Telco Output Rule Number: 0
Telco Parameters
Tx Gain   :-4 dB      E&M Type :1
Rx Gain   :-4 dB      E&M Wire :4
OOS Signal:Busy     E&M Start:Immediate
Dsp Parameters
Vocoder Suite :Nuera  VAD Mode      :Off
Vocoder Rate  :9600   VAD Hangover  :255 ms
Frame Packing :1      VAD Threshold :-45 dB
Echo Cancel  :0n      Fax           :0n
NLP          :0n      NSF           :0n
2100Hz Detect :0n      Max Fax Rate :Vocoder Rate
```

#### Node ID

Indicates the IBM 9783 Node ID of the voice interface.

#### Local Telephone Number

Indicates the local telephone number of the voice interface.

#### Telco Output Rule

Indicates the current telco output rule being used by the voice interface.

#### Tx Gain

Indicates current transmit gain in decibels.

#### Rx Gain

Indicates the current receiver gain in decibels.

#### OOS Signal

Indicates the type of signal that will be used if the interface should be out of service.

## Voice Feature Commands (Talk 6)

### **E&M Type**

Indicates the type of telco interface being used by the voice interface.

### **E&M Wire**

Indicates if this is a 2-wire or 4-wire voice interface.

### **E&M Start**

Indicates how the voice interface will start its transmission.

### **Vocoder Suite**

Indicates the vocoder suite (either ITU or NUERA) which is currently available on the voice interface.

### **Vocoder Rate**

Indicates the current vocoder rate.

### **VAD Mode**

Indicates the type of VAD used. You can specify fixed, adaptive, or off.

### **VAD Hangover**

Indicates the length of time the input signal level must remain below the VAD threshold value before the link is considered to be silent.

### **VAD Threshold**

Indicates the signal level (in decibels) to be used to determine when a link is silent.

**NLP** Indicates if Non-Linear Processing is enabled (On) or disabled (Off).

### **2100Hz Detect**

Indicates if 2100Hz detection is enabled (On) or disabled (Off).

**FAX** Indicates if FAX Relay is enabled (On) or disabled (Off).

**NSF** Indicates if Non-Standard Facilities is enabled (On) or disabled (Off).

### **Max Fax Rate**

The maximum rate at which the Fax will connect.

See the "Set" command for a description of additional parameters.

## Set

Use the **set** command to specify the setting for a specific voice interface.

### **Syntax:**

```
set                echo-cancel  
                   fax  
                   frame-packing  
                   local-number  
                   node-id  
                   oos  
                   rate  
                   rx-gain  
                   start  
                   suite  
                   telco-output-rule  
                   tx-gain  
                   type (E&M-only)  
                   vad  
                   wire
```

## Voice Feature Commands (Talk 6)

The following parameters can be specified on the **set** command:

### **echo-cancel**

Specifies whether or not to enable echo cancellation, nlp, or detect-2100Hz.

**Valid Values:** on, off, nlp, or detect-2100Hz

**Default Value:** on

### **nlp**

**Valid Values:** on or off

**Default Value:** on

### **detect-2100Hz**

**Valid Values:** on or off

**Default Value:** on

### **Example:**

```
Voice 8 Config>se on
```

**fax** Specifies whether or not to enable fax, nsf, and the maximum rate at which fax will connect.

**Valid Values:** on, off, nsf, or max-rate

**Default Value:** on

**nsf** Specifies whether or not to enable nsf.

**Valid Values:** on or off

**Default Value:** on

### **max-rate**

Specifies the max-rate.

**Valid Values:** Vocoder Rate, 4.8 Kb or 9.6 Kb

**Default Value:** Vocoder Rate

### **Example:**

```
Voice 8 Config>se fa on
```

### **frame-packing**

Specifies the number of voice frames that will be packed into a single Frame Relay packet.

**Valid Values:** 1 to 5

**Default Value:** 1

### **Example:**

```
Voice 8 Config>se fr
Frame Packing (1 to 5) [1]?
```

### **local-number**

Specifies the local telephone number of the specified voice interface.

**Valid Values:** any 20-digit (0 to 9, A to D, \*,#) number

**Default Value:** 0

### **Example:**

```
Voice 8 Config>s 1
Local Phone Number (1 to 20 digits, range 0-9, A-D, *, #) [0]? 524
Number of leading digits used for local call routing (1 to 3) [3]?
```

### node-id

Specifies the Node ID of the interface.

**Valid Values:** any valid Node ID (IP Address)

**Default Value:** 0.0.0.0

**Example:**

```
Voice 8 Config>s n
Node ID (IP Address) [0.0.0.0]? 1.2.4.2
```

**oos** Specifies the type of tone you want to use to indicate that the specified voice interface is out-of-service.

**Valid Values:** idle or busy

**Default Value:** busy

**Example:**

```
Voice 8 Config>s o busy
```

**rate** Specifies the transmission rate of the voice interface.

**Valid Values:** If you specify Nuera as the suite parameter, you can choose either 4.8 KB, 7.47 KB, 9.6 KB, or 32 KB. If you specify ITU as the suite parameter, you can choose either 8 KB, 16 KB, or 32 KB.

**Default Value:** 9.6 KB

### rx-gain

Specifies the amount that the voice interface attenuates (or amplifies) the receive signal.

**Valid Values:** -16 dB to +7 dB

**Default Value:** 0 dB

**Example:**

```
Voice 8 Config>s rx
Gain (-16 to +7 dB) [0]?
```

### start (E&M-only)

Specifies how the voice interface starts its transmissions.

**Valid Values:** immediate start or wink start

**Default Value:** immediate start

**Example:**

```
Voice 8 Config>s st immediate
```

**suite** Specifies the type of protocol you want the voice interface to use.

**Valid Values:** NUERA – ECELP/G.726 or ITU – G.729/G728/G.726

**Default Value:** NUERA

**Example:**

```
Voice 8 Config>s su I
```

### telco-output-rule

Specifies which telco output rule to be used.

**Valid Values:** 0 to 8. The upper limit depends on the number of Telco output rules that have been defined.

## Voice Feature Commands (Talk 6)

**Default Value:** 0

**Example:**

```
Voice 8 Config>s te
Telco Output Rule Number (0 to 1) [0]? 1
```

### **tx-gain**

Specifies the amount that the voice interface attenuates (or amplifies) the transmitted signal.

**Valid Values:** -16 dB to +7 dB

**Default Value:** 0 dB

**Example:**

```
Voice 8 Config>s tx
Gain (-16 to +7 dB) [0]?
```

### **type (E&M-only)**

Specifies the telco E&M interface type for the specified voice interface.

**Valid Values:** 1,2, or 5

**Default Value:** 1

**Example:**

```
Voice 8 Config>s ty
E&M Type (1,2,5) [1]?
```

### **vad** Specifies the following:

**mode** Specifies the vad mode.

**Valid Values:** fixed, adaptive, or off

**Default Value:** off

**hangover**

Specifies the vad hangover.

**Valid Values:** 1 to 500 ms

**Default Value:** 255 ms

**threshold**

Specifies the vad threshold.

**Valid Values:** -15 to -60 dB

**Default Value:** -45 dB

### **wire (E&M-only)**

Specifies whether you are using a 2-wire or 4-wire telco connection.

**Valid Values:** 2-wire (2) or 4-wire telco (4)

**Default Value:** 4

**Example:**

```
Voice 8 Config>s w
E&M Wire (2,4) [4]?
```

---

## Accessing the Voice over Frame Relay (VoFR) Commands

Use the following procedure to access the voice over Frame Relay commands.

## Voice Feature Commands (Talk 6)

1. At the OPCON prompt, enter **talk 6**. (For more detail on this command, refer to *The OPCON Process and Commands* in the Access Integration Services Software User's Guide.) For example:

```
* talk 6
Config>
```

After you enter the **talk 6** command, the CONFIG prompt (Config>) displays on the command line. If the prompt does not appear when you first enter configuration, press **Return** again.

2. At the CONFIG prompt, enter the **feat voice** to get the voice config> prompt.
3. At the voice config> prompt, enter **VoFR** to get to the VoFR config> prompt

---

## Voice over Frame Relay (VoFR) Commands

This section describes the Voice over Frame Relay commands and the configurable parameters for the VoFR menu.

Table 67. VoFR Configuration Command Summary

Command	Function
? (Help)	Displays all the commands available for this command level or lists the options for specific commands (if available). See "Getting Help" on page xxxii.
Add	Adds a call-processing-rule, dial-matching-rule, or network-output-rule.
Delete	Deletes a network-output-rule, dial-matching-rule, or call-processing-rule.
Disable	Disables Voice over Frame Relay on the specified voice network interface.
Enable	Enables Voice over Frame Relay on the specified voice network interface.
List	Lists fr-net (frame relay net), interfaces, network-output-rule, dial-matching-rule, call-processing-rule, or all list items.
Modify	Updates a call-processing-rule, dial-matching-rule, or network-output-rule.
Reorder-call-rule	Reorders the call rules.
Set	Sets the fr-net (frame relay net).
Exit	Returns you to the previous command level. See "Exiting a Lower Level Environment" on page xxxii.

### Add

This command adds a network-output-rule, a dial-matching-rule, or a call-processing-rule to the VoFR configuration.

#### Syntax:

```
add                call-processing-rule
                   dial-matching-rule
                   network-output-rule
```

#### call-processing-rule

Specifies call-processing rules. For out-going calls, call processing rules are evaluated in ascending order by comparing the dialed digits to the dial digit matching rule associated with each call processing rule. If a match is found, the network output rule and call routing information in the call processing rule are used to process the call. Because a voice interface can accept calls from any destination specified in any of its associated call routing rules, this rule has no effect. Up to eight call processing rules can be defined for each voice interface.

**Note:** The call processing rule is analogous to the IBM 9783's Translation Rule, which combines a network output rule and a dial matching rule

## Voice Feature Commands (Talk 6)

with call routing information (DLCI and subchannel specification in the case of a remote call route, number of destination digits to compare to local numbers in the case of a local call route).

### Example:

```
VoFR Config>a c
Voice Net [0]? 8

Define Call Processing Rule #2

Destination Type (Local or Remote) [Remote]?
Call Processing DLCI (16 to 1007) [16]?
Payload DLCI (16 to 1007) [16]?
Call Processing Subchannel (4 to 254) [4]?
Payload Subchannel (4 to 254) [4]? 5
Dial Digit Matching Rule Number (0 to 3) [0]? 2
Network Output Rule Number (0 to 3) [0]? 1
```

```
VoFR Config>a c
Voice Net [0]? 8

Define Call Processing Rule #3

Destination Type (Local or Remote) [Remote]? 1
Dial Digit Matching Rule Number (0 to 3) [0]? 1
Network Output Rule Number (0 to 2) [0]? 1
```

### Destination Type

Specifies whether the destination node is on another 2212/IBM 9783 (Remote) or another voice interface on the same 2212 (Local).

### Call Processing DLCI

Specifies the DLCI that will be used to set up and then terminate the call.

### Payload DLCI

Specifies the DLCI that will be used to send and receive the compressed voice data packets.

### Call Processing Subchannel

Specifies the subchannel that will be used to set up and then terminate the call.

### Payload Subchannel

Specifies the subchannel that will be used to send and receive the compressed voice data packets.

### Dial Digit Matching Rule

Specifies the number of the dial digit matching rule to be used for this call processing rule.

### Network Output Rule

Specifies the number of the network output rule to be used for this call processing rule.

### dial-matching-rule

Specifies a dial digit pattern-matching sequence in which each element of the sequence specifies the range of acceptable digits at that position.

**Note:** The dial matching rule is analogous to the IBM 9783's Destination Match Rule.

### Example:

```
VoFR Config>a d
Define Dial Digit Matching Rule #3
```



## Voice Feature Commands (Talk 6)

Dial Mask 1 : Digit String (0-9,A-D,\*,#), [W]ildcard, [N]umeric Wildcard, [M]ultiDigit Wildcard.  
[MultiDigit Wildcard]?

Dial Mask 2 : Digit String (0-9,A-D,\*,#), [W]ildcard, [N]umeric Wildcard, [M]ultiDigit Wildcard, or [E]nd.  
[End]?

Matching Rule contains MultiDigit Wildcard(s).  
Minimum number of digits accepted for MultiDigit Wildcard (0,1) [1]?

### Dial Mask #

Specifies one of a set of from 1 to 20 dial digit masks. Each mask specifies the acceptable range of the digit at that position in the 20 digit dial sequence.

### Digit String

Specifies a set of digits from which the digit must be chosen.

### Wildcard

Specifies that the digit must one of the following: 0-9, A-D, #, or \*.

### Numeric Wildcard

Specifies the digit must be 0–9.

### Multidigit Wildcard

Specifies that more than one digit is acceptable at the specified position. If the multidigit wildcard mask is the last one in the dial matching rule, then any digit (0–9, A–D, #, \*) may be entered at this point in the sequence. In this case the voice interface continues to collect digits until either 20 digits are entered or the Interdigit Timeout expires without additional digits being entered. If a mask follows the multidigit wildcard, the voice interface continues to collect digits that satisfy the multidigit mask until a digit is entered that satisfies the mask following the multidigit wildcard mask.

### network-output-rule

Specifies the destination number digits to be passed in the Frame Relay call setup packet. The sequence is specified as a combination of the dialed digits received on the originating telco interface and constants.

**Note:** The network output rule is analogous to the IBM 9783's Destination Output Rule for a Frame Relay interface.

### Example:

```
VoFR Config>a n
Define Network Output Rule #2
Digit 1 : (Destination/Constant/End) [Destination]?
          (1-20) [1]?
Digit 2 : (Destination/Constant/End) [Destination]? e
```

### Digit #

Specifies how the specific dial digit is determined.

### Destination

Specifies to use the digit from the specified position in the destination phone number.



**call processing rule**

Lists call processing rule for the specified voice interface. If a specific interface number is not specified, the Voice Net [0] prompt is displayed enabling you to specify the interface number.

**Example:**

```
VoFR config>list call 7

Call Processing Rule #1

Call Processing      DLCI      = 16
Payload             DLCI      = 16
Call Processing     Subchannel = 4
Payload             Subchannel = 5
Dial Digit Matching Rule # = 1
Network Output      Rule #    = 1

Call Processing Rule #2

Call Processing      DLCI      = 16
Payload             DLCI      = 16
Call Processing     Subchannel = 6
Payload             Subchannel = 7
Dial Digit Matching Rule # = 2
Network Output      Rule #    = 2
```

**Call processing DLCI**

Indicates the call processing DLCI defined for this interface.

**Payload DLCI**

Indicates the payload DLCI defined for this interface.

**Call processing subchannel**

Indicates the call processing subchannel defined for this interface.

**Payload subchannel**

Indicates the payload subchannel defined for this interface.

**Dial digit matching rule**

Indicates the dial digit matching rule currently being used by this interface.

**Network output rule**

Indicates the network output rule currently being used by this interface.

**dial matching rule**

Lists dial digit matching rule for the specified voice interface. If a rule number is not specified, the Rule # prompt is displayed.

**Example:**

```
Voice config>list dial

Rule # (0 to 2) or all [all]? 1

Dial Digit Matching Rule #1

Dial Mask 1 : Match Digits = 0123456789
Dial Mask 2 : Match Digits = 0123456789
Dial Mask 3 : Match Digits = 0123456789
Dial Mask 4 : Match Digits = 0123456789
```

**fr-net** Lists the number for the Frame Relay net over which VoFR packets are to be routed.

**interfaces**

Lists whether Voice over Frame Relay has been enabled or disabled for each voice interface, where:

- Net specifies the voice network interface number.

## Voice Feature Commands (Talk 6)

- VoFR specifies whether Voice Over Frame Relay is enabled or disabled on the voice network.

### Example:

```
VoFR Config>list interface
Net    VoFR
4      Disabled
5      Disabled
6      Disabled
7      Disabled
8      Enabled
9      Disabled
```

### network-output-rule

Lists the specified network output rule. If a rule number is not specified, the Rule # prompt is displayed.

### Example:

```
VoFR Config>1 n
Rule # (0 to 1) or all [all]? 1

Destination Number Generation Rule #1

Dial Digit 1 : Digit 1 from Destination Number
```

## Modify

This command updates a network-output-rule, a dial-matching-rule, or a call-processing-rule in the VoFR configuration.

### Syntax:

```
modify                call-processing-rule
                        dial-matching-rule
                        network-output-rule
```

For an explanation of the call-processing-rule, dial-matching-rule, and the network-output-rule, see “Add” on page 605.

### Example:

```
VoFR Config>modify call-processing-rule
Voice Net [0]? 8
Rule # (1 to 2) [1]?

Define Call Processing Rule #1

Destination Type (Local or Remote) [Remote]?
Call Processing DLCI (16 to 1007) [16]?
Payload          DLCI (16 to 1007) [16]?
Call Processing Subchannel (4 to 254) [4]?
Payload          Subchannel (4 to 254) [5]?
Dial Digit Matching Rule Number (0 to 2) [0]? 2
Network Output Rule Number (0 to 1) [0]? 1
```

### Example:

```
VoFR Config>modify dial-matching-rule
Rule # (1 to 2) [1]?

Define Dial Digit Matching Rule #1

Dial Mask 1 : Digit String (0-9,A-D,*,#), [W]ildcard, [N]umeric Wildcard,
                    [M]ultiDigit Wildcard.
                    [0123456789]?

Dial Mask 2 : Digit String (0-9,A-D,*,#), [W]ildcard, [N]umeric Wildcard,
                    [M]ultiDigit Wildcard, or [E]nd.
                    [0123456789]?

Dial Mask 3 : Digit String (0-9,A-D,*,#), [W]ildcard, [N]umeric Wildcard,
                    [M]ultiDigit Wildcard, or [E]nd.
```

```
[0123456789]?
Dial Mask 4 : Digit String (0-9,A-D,*,#), [W]ildcard, [N]umeric Wildcard,
[M]ultiDigit Wildcard, or [E]nd.
[0123456789]?
Dial Mask 5 : Digit String (0-9,A-D,*,#), [W]ildcard, [N]umeric Wildcard,
[M]ultiDigit Wildcard, or [E]nd.
[End]?
```

### Example:

```
VoFR Config>modify network-output-rule
Rule # (1 to 1) [1]?

Define Network Output Rule #1

Digit 1 : (Destination/Constant/End) [Destination]?
(1-20) [1]?
Digit 2 : (Destination/Constant/End) [Destination]?
(1-20) [2]?
Digit 3 : (Destination/Constant/End) [Destination]?
(1-20) [3]?
Digit 4 : (Destination/Constant/End) [Destination]?
(1-20) [4]?
Digit 5 : (Destination/Constant/End) [Destination]?
(1-20) [5]?
Digit 6 : (Destination/Constant/End) [Destination]?
(1-20) [6]?
Digit 7 : (Destination/Constant/End) [Destination]?
(1-20) [7]?
Digit 8 : (Destination/Constant/End) [Destination]? e
```

## Reorder-call-rule

This command changes the order in which the call processing rules are processed for the voice interface (when VoFR is enabled).

### Syntax:

**reorder-call-rule**

For **reorder-call-rule**, you will have to provide the voice interface number, and will be prompted if it is not specified when you enter the command.

### Example:

```
VoFR Config>r
Voice Net [0]? 8
Current Rule # (1 to 2) [1]?
New Rule # (1 to 2) [1]? 2
```

## Set

This command sets a Frame Relay net for the VoFR configuration.

### Syntax:

**set** fr-net

**fr-net** Use the **set fr-net** command to specify the number of the Frame Relay net over which VoFR packets are to be routed. Specify any configured net number.

### Example:

```
VoFR Config>s f
Frame Relay Net for Voice Traffic [65535]? 2
```

### Accessing the Voice Interface Monitoring Environment

Use the following procedure to access the voice interface monitoring commands.

1. At the OPCON prompt, enter **talk 5**. (For more detail on this command, refer to “The OPCON Process and Commands” in the *Access Integration Services Software User’s Guide*.)

2. For example:

```
* talk 5
+
```

After you enter the **talk 5** command, the GWCON prompt (+) displays on the command line.

3. At the + prompt, enter the **network n** command to get you to the Voice n Console> prompt.

**Example:**

```
+ network 2
Voice 2 Console>
```

### Voice Interface Monitoring Commands

This section describes the voice interface monitoring commands.

*Table 68. Voice Interface Monitoring Command Summary*

Command	Function
? (Help)	Displays all the commands available for this command level or lists the options for specific commands (if available). See “Getting Help” on page xxxii.
Calls	Display various event and message counters associated with the specified voice interface.
Status	Display various voice interface settings as well as transmit and receive error information.
Trace call	Displays various trace information about a target interface.
Exit	Returns you to the previous command level. See “Exiting a Lower Level Environment” on page xxxii.

### Calls

Use the **calls** command to display call processing messages and event counters.

**Syntax:**

**calls**

**Example:**

```
Voice 1 Console> calls
```

Event Counters

Seize Detected	5	Digit Detected	4
Seize Applied	0	Digit Generated	0

Message Counters

Setup Sent	1	Setup Received	0
Connect Sent	0	Connect Received	1
Answer Sent	0	Answer Received	1
Release Sent	2	Release Received	0

Release Cause Counters

Normal	1	Response	0
--------	---	----------	---

## Voice Interface Monitoring Commands (Talk 5)

Busy	1	OOS	0
Local Bandwidth	0	Incompatible	0
Remote Bandwidth	0		

### Event Counters

Indicates the number of events that occur on the telco interface.

#### Seize Detected

Indicates the number of Seize In events (phone attached to the voice interface goes off—hook).

#### Seize Applied

Indicates the number of Seize Out events (voice interface itself goes off—hook).

#### Digit Detected

Indicates the number of dial digits received from the subscriber on the telco interface.

#### Digit Generated

Indicates the number of dial digits sent to the subscriber on the telco interface.

### Message Counters

Indicates the number of call processing messages sent to or received from a voice interface over the Frame Relay circuit. Setup, Connect, and Answer messages flow between the two end nodes when a call is established. The initiator of the call sends a Setup message to the remote end which responds with a Connect message followed by an Answer message if the call is successful. If a call cannot be completed, a Release message is sent by the remote node. Release messages are also sent by each end when a successful call ends normally (both end nodes go on-hook).

#### Setup Sent

Indicates the number of Setup messages sent.

#### Connect Sent

Indicates the number of Connect messages sent.

#### Answer Sent

Indicates the number of Answer messages sent.

#### Release Sent

Indicates the number of Release messages sent.

#### Setup Received

Indicates the number of Setup messages received.

#### Connect Received

Indicates the number of Connect messages received.

#### Answer Received

Indicates the number of Answer messages received.

#### Release Received

Indicates the number of Release messages received.

### Release Cause Counters

Indicates the causes of the Release message.

#### Normal

Indicates the number of normal hang-ups initiated by the near-end (local) node.

## Voice Interface Monitoring Commands (Talk 5)

**Busy** Indicates the number of hang-ups caused by a busy channel.

### Local Bandwidth

Indicates the number of hang-ups caused by insufficient local bandwidth.

### Remote Bandwidth

Indicates the number of hang-ups caused by insufficient remote bandwidth.

### Response

Indicates the number of normal hang-ups initiated by the far-end (remote) node.

**OOS** Indicates the number of hang-ups caused by the far-end being out-of-service.

### Incompatible

Indicates the number of hang-ups caused by incompatibility of the end nodes.

## Status

Use the **status** command to display information about a specific voice interface.

### Syntax:

**status**

### Example:

```
Voice 1 Config> status
```

```
Voice Over Frame Relay :Enabled
Node ID                :0.0.0.0
Absolute interface Address :01
```

Vocoder Suite	Nuera	Echo Cancellor	Filter
Vocoder Active	ECELP	Fax Demodulation	Idle
Vocoder Rate	9600	Fax Modulation	Idle
Vocoder Packet Size	18	Fax Type	V.27 at 9600 bps
Vocoder Frame Size	120	Fax Last FCF	0

```
Last Received Dial Sequence :8675309
Last Transmitted Dial Sequence :911
```

```
Transmit Packets                Receive Packets
```

Total	179	Total	184
Voice	169	Voice	167
CAS	0	CAS	11
DTMF	0	DTMF	0
FAX	0	FAX	0
Lost	0	Lost	0

### Voice over Frame Relay

Indicates whether Voice over Frame Relay is enabled or disabled on this interface.

### Node ID

Indicates the IBM 9783 Node ID of the voice interface.

### Absolute Interface Address

Indicates the 2212 voice interface identifier used for IBM 9783 call accounting. This address is automatically generated by the 2212 software and is unique for each voice interface on a specific 2212.



## Voice Interface Monitoring Commands (Talk 5)

### **Vocoder Suite**

Indicates the vocoder suite (either ITU or NUERA) which is currently available on the voice interface.

### **Vocoder Active**

Indicates the vocoder that is currently active on the interface.

### **Vocoder Rate**

Indicates the current vocoder rate.

### **Vocoder Packet Size**

Indicates the number of bytes in each vocoder packet. This is the size of the raw compression output and does not include the frame relay header.

### **Vocoder Frame Size**

Indicates the number of PCM samples in each vocoder frame.

### **Echo Canceller**

Indicates the current state of the echo canceller.

### **FAX Demodulation**

Indicates the current FAX demodulation status. The status can be Active or Idle.

### **FAX Modulation**

Indicates the current FAX modulation status. The status can be Active or Idle.

### **FAX Type**

Indicates the type of modulation being used.

### **FAX Last FCF**

Indicates the last demodulated Facsimile Control Field.

### **Last Received Dial Sequence**

Indicates the last dial digit sequence received from the subscriber over the telco interface.

### **Last Transmitted Dial Sequence**

Indicates the last dial digit sequence sent to the subscriber over the telco interface.

### **Transmit Packets/ Receive Packets**

Indicates various information about transmitted and received Frame Relay packets. Transmitted packets are those packets that are generated by the voice interface and sent out over the Frame Relay link. Receive packets are those packets that are received by the voice interface from the Frame Relay link.

**Total** Indicates the total number of packets received or transmitted.

**Voice** Indicates the number of compressed voice packets received or transmitted.

**CAS** Indicates the number of CAS packets received or transmitted.

**DTMF** Indicates the number of DTMF packets received or transmitted.

**FAX** Indicates the number of FAX packets received or transmitted.

**Lost** Indicates either the number of packets sent by the local node but not received by the remote node (transmit packets), or the number of packets sent by the remote node but not received by the local node (receive packets).

## Voice Interface Monitoring Commands (Talk 5)

### Trace Call

Use the **trace call** command to trace all set up messages or configuration control commands for the target interface. You can view the trace events by using ELS (talk 2).

**Syntax:**

```
trace call
```

---

## Voice Feature Dynamic Reconfiguration Support

This section describes dynamic reconfiguration (DR) as it affects Talk 6 and Talk 5 commands.

### CONFIG (Talk 6) Delete Interface

Voice Feature supports the CONFIG (Talk 6) **delete interface** command with no restrictions.

### GWCON (Talk 5) Activate Interface

Voice Feature does not support the GWCON (Talk 5) **activate interface** command.

### GWCON (Talk 5) Reset Interface

Voice Feature supports the GWCON (Talk 5) **reset interface** command with the following consideration:

- All Voice Feature parameters except FR-NET can be modified dynamically. Voice Feature parameters are defined once-per-router and apply to all voice interfaces on the router. After a Voice Feature parameter is changed, each voice interface must be manually reset in order for the change to be applied to it.

---

## Voice Interfaces Dynamic Reconfiguration Support

This section describes dynamic reconfiguration (DR) as it affects Talk 6 and Talk 5 commands.

### CONFIG (Talk 6) Delete Interface

Voice Interfaces support the CONFIG (Talk 6) **delete interface** command with the following consideration:

- If one of the voice ports on a 2-port voice adapter is deleted, the other port on the adapter will be automatically deleted, because there is a restriction that requires both ports on a 2-port voice adapter to be configured as present.

### GWCON (Talk 5) Activate Interface

Voice Interfaces do not support the GWCON (Talk 5) **activate interface** command.

### GWCON (Talk 5) Reset Interface

Voice Interfaces support the GWCON (Talk 5) **reset interface** command. All Voice Interface parameters can be modified dynamically.

---

## Appendix. Remote AAA Attributes

This section identifies the remote AAA Attributes used by Radius, TACACS and TACACS+ servers.

---

### Radius

IBM Vendor ID: 211

#### Authorization Attributes

##### Standard Drafted

TUNNEL_TYPE	64
TUNNEL_MEDIUM_TYPE	65
TUNNEL_CLIEN_TYPE	66
TUNNEL_SERVER_EP	67
TUNNEL_CONN_ID	68
TUNNEL_PASSWORD	69

values

TUNNEL_TYPE		integer
1	PPTP	
2	L2F	
3	L2TP	
TUNNEL_MEDIUM_TYPE		integer
1	IP	
TUNNEL_SERVER_EP		string
	ip address	

##### IBM Vendor Specific

NAS_TUNNEL_PASSWORD	101
INBYTES_AH	110
INBYTES_ESP	111
OUTBYTES_AH	112
OUTBYTES_ESP	113
INPKTS_BAD	114
OUTPKTS_BAD	115
INPKTS_BAD_AH	116
INPKTS_BAD_ESP	117
OUTPKTS_BAD_AH	118
OUTPKTS_BAD_ESP	119
INPKTS_AH	120
AH INPKTS_ESP	121
OUTPKTS_AH	122
AH OUTPKTS_ESP	123
INPKTS_BAD_AH_RPLY	124

INPKTS_BAD_ESP_RPLY	125
INBYTES_WRAP	128
OUTBYTES_WRAP	129
INB_AH_WRAP	130
INB_ESP_WRAP	131
OUB_AH_WRAP	132
OUB_ESP_WRAP	133
POLICY_NAME	135
P1_ID	136
TRANSFORMS	137
REFR_CNT	138
COMPR	139
ESP_ALGO	140
AH_ALGO	141
ESPAUTH_ALGO	142
P1_NAME	143
VC-ACTIVE	177
VC-IDLETIME	179
VC-SUSPENDTIME	180
CALLBACK_FLAGS	210
ENCRYPTION	211
HOSTNAME	213
SUBNETMASK	215
PRIVILEGE	216

## Keywords

Keywords are used for Radius servers that allow the entry of vendor specific fields  
<keyword>=<value>.

KWD_VC_ACTIVE	VCN
KWD_VC_IDLETIME	VCI
KWD_VC_SUSPENDTIME	VCS
KWD_CALLBACK_FLAGS	CBF
KWD_ENCRYPTION	ENC
KWD_HOSTNAME	HSN
KWD_SUBNETMASK	SNM
KWD_PRIVILEGE	PRV

Values

CALLBACK_FLAGS	
REQ	required callback
ROAM	roaming callback

PRIVILEGE:

    ADMIN  
    OPER  
    MONITOR

## Example of RADIUS Configuration File

The following is an example of a RADIUS configuration file:

```
VENDOR IBM 211
ATTRIBUTE      User-Name          1          string
ATTRIBUTE      User-Password      2          string
ATTRIBUTE      CHAP-Password      3          string
ATTRIBUTE      NAS-IP-Address     4          ipaddr
ATTRIBUTE      NAS-Port           5          integer
ATTRIBUTE      Service-Type       6          integer
ATTRIBUTE      Framed-Protocol    7          integer
ATTRIBUTE      Framed-IP-Address  8          ipaddr
ATTRIBUTE      Framed-IP-Netmask  9          ipaddr
ATTRIBUTE      Framed-Routing     10         integer
ATTRIBUTE      Filter-Id          11         string
ATTRIBUTE      Framed-MTU         12         integer
ATTRIBUTE      Framed-Compression 13         integer
ATTRIBUTE      Login-IP-Host      14         ipaddr
ATTRIBUTE      Login-Service      15         integer
ATTRIBUTE      Login-TCP-Port     16         integer #
ATTRIBUTE      Old-Password       17         string
ATTRIBUTE      Reply-Message      18         string
ATTRIBUTE      Callback-Number    19         string
ATTRIBUTE      Callback-Id        20         string #
ATTRIBUTE      Unassigned         21         string
ATTRIBUTE      Framed-Route       22         string
ATTRIBUTE      Framed-IPX-Network 23         integer
ATTRIBUTE      State              24         string
ATTRIBUTE      Class              25         string
ATTRIBUTE      Vendor-Specific    26         string
ATTRIBUTE      Session-Timeout    27         integer
ATTRIBUTE      Idle-Timeout       28         integer
ATTRIBUTE      Termination-Action 29         integer
ATTRIBUTE      Called-Station-Id  30         string
ATTRIBUTE      Calling-Station-Id 31         string
ATTRIBUTE      NAS-Identifier      32         string
ATTRIBUTE      Proxy-State        33         string
ATTRIBUTE      Login-LAT-Service  34         string
ATTRIBUTE      Login-LAT-Node     35         string
ATTRIBUTE      Login-LAT-Group    36         string
ATTRIBUTE      Framed-Appletalk-Link 37         integer
ATTRIBUTE      Framed-Appletalk-Net 38         integer
ATTRIBUTE      Framed-Appletalk-Zone 39         string
ATTRIBUTE      Acct-Status-Type    40         integer
ATTRIBUTE      Acct-Delay-Time     41         integer
ATTRIBUTE      Acct-Input-Octets   42         integer
ATTRIBUTE      Acct-Output-Octets  43         integer
ATTRIBUTE      Acct-Session-Id    44         string
ATTRIBUTE      Acct-Authentic      45         integer
ATTRIBUTE      Acct-Session-Time   46         integer
ATTRIBUTE      Acct-Input-Packets  47         integer
ATTRIBUTE      Acct-Output-Packets 48         integer
ATTRIBUTE      Acct-Terminate-Cause 49         integer
ATTRIBUTE      Acct-Multi-Session-Id 50         string
ATTRIBUTE      Acct-Link-Count     51         integer
```

ATTRIBUTE	CHAP-Challenge	60	string
ATTRIBUTE	NAS-Port-Type	61	integer
ATTRIBUTE	Port-Limit	62	integer
ATTRIBUTE	Login-LAT-Port	63	string
----- START IBM -----			
ATTRIBUTE	Tunnel-Type	64	integer
ATTRIBUTE	Tunnel-Medium	65	integer
ATTRIBUTE	Tunnel-Client-EP	66	string
ATTRIBUTE	Tunnel-Server-EP	67	string
ATTRIBUTE	Tunnel-Conn-ID	68	string
ATTRIBUTE	Tunnel-Password	69	string
ATTRIBUTE	Tunnel-NAS-Password	101	string
ATTRIBUTE	VC-ACTIVE	177	integer
ATTRIBUTE	VC-IDLETIME	179	integer
ATTRIBUTE	VC-SUSPENDTIME	180	integer
ATTRIBUTE	IBM-Callback-Flags	210	string
ATTRIBUTE	IBM-Encryption	211	string
ATTRIBUTE	IBM-DialOut	214	string
ATTRIBUTE	IBM-Hostname	213	string
ATTRIBUTE	IBM-Subnetmask	215	string
ATTRIBUTE	IBM-Privilege	216	string
ATTRIBUTE	IBM-ipsec-inb-ah	110	integer
ATTRIBUTE	IBM-ipsec-inb-esp	111	integer
ATTRIBUTE	IBM-ipsec-ob-ah	112	integer
ATTRIBUTE	IBM-ipsec-ob-esp	113	integer
ATTRIBUTE	IBM-ipsec-ip-bad	114	integer
ATTRIBUTE	IBM-ipsec-op-bad	115	integer
ATTRIBUTE	IBM-ipsec-ip-bad-ah	116	integer
ATTRIBUTE	IBM-ipsec-ip-bad-esp	117	integer
ATTRIBUTE	IBM-ipsec-op-bad-ah	118	integer
ATTRIBUTE	IBM-ipsec-op-bad-esp	119	integer
ATTRIBUTE	IBM-ipsec-ip-ah	120	integer
ATTRIBUTE	IBM-ipsec-ip-esp	121	integer
ATTRIBUTE	IBM-ipsec-op-ah	122	integer
ATTRIBUTE	IBM-ipsec-op-esp	123	integer
ATTRIBUTE	IBM-ipsec-ip-bad-ah-r	124	integer
ATTRIBUTE	IBM-ipsec-ip-bad-esp-r	125	integer
ATTRIBUTE	IBM-ipsec-inb-wrap	128	integer
ATTRIBUTE	IBM-ipsec-ob-wrap	129	integer
ATTRIBUTE	IBM-ipsec-ib-ah-wrap	130	integer
ATTRIBUTE	IBM-ipsec-ib-esp-wrap	131	integer
ATTRIBUTE	IBM-ipsec-ob-ah-wrap	132	integer
ATTRIBUTE	IBM-ipsec-ob-esp-wrap	133	integer
ATTRIBUTE	IBM-ipsec-policy-name	135	string
ATTRIBUTE	IBM-ipsec-p1-id	136	string
ATTRIBUTE	IBM-ipsec-p1-name	143	string
ATTRIBUTE	IBM-ipsec-esp-algo	140	string
ATTRIBUTE	IBM-ipsec-ah-algo	141	string
ATTRIBUTE	IBM-ipsec-esp-algo	142	string
VALUE	Tunnel-Type	L2TP	3
VALUE	Tunnel-Type	L2F	2
VALUE	Tunnel-Type	PPTP	1
VALUE	Tunnel-Medium	IP	1
VALUE	VC-ACTIVE	YES	1

VALUE	VC-ACTIVE	NO	0
VALUE	IBM-Callback-Flags	Required	REQ
VALUE	IBM-Callback-Flags	Roaming	OAM
VALUE	IBM-Dialout	Enable	TRUE
VALUE	IBM-Dialout	Disable	FALSE
VALUE	IBM-Dialout	ONLY	ONLY
VALUE	IBM-Privilege	Administrator	ADMIN
VALUE	IBM-Privilege	Operator	OPER
VALUE	IBM-Privilege	Monitor	MONITOR

---

## TACACS+

### Authentication

### Authorization

PPP service=ppp protocol=ip  
 LOGIN service=shell cmd=null pri\_lvl\*0

#### Standard TACACS+ Attributes

service  
 protocol  
 cmd  
 addr  
 timeout  
 priv\_lvl 0 (monitor privilege), 1 (operator privilege), 15 (administr  
 callback-dialstring

#### IBM Specific Attributes

encryption\_key 16 hex characters  
 dial\_out TRUE FALSE ONLY

### Accounting

task\_id  
 start\_time  
 stop\_time  
 elapsed\_time  
 timezone  
 event  
 reason  
 bytes  
 bytes\_in  
 bytes\_out  
 paks  
 paks\_in  
 paks\_out  
 status  
 err\_msg





---

## List of Abbreviations

<b>AARP</b>	AppleTalk Address Resolution Protocol
<b>ABR</b>	area border router
<b>ack</b>	acknowledgment
<b>AIX</b>	Advanced Interactive Executive
<b>AMA</b>	arbitrary MAC addressing
<b>AMP</b>	active monitor present
<b>ANSI</b>	American National Standards Institute
<b>AP2</b>	AppleTalk Phase 2
<b>APPN</b>	Advanced Peer-to-Peer Networking
<b>ARE</b>	all-routes explorer
<b>ARI/FCI</b>	address recognized indicator/frame copied indicator
<b>ARP</b>	Address Resolution Protocol
<b>AS</b>	autonomous system
<b>ASBR</b>	autonomous system boundary router
<b>ASCII</b>	American National Standard Code for Information Interchange
<b>ASN.1</b>	abstract syntax notation 1
<b>ASRT</b>	adaptive source routing transparent
<b>ASYNC</b>	asynchronous
<b>ATCP</b>	AppleTalk Control Protocol
<b>ATP</b>	AppleTalk Transaction Protocol
<b>AUI</b>	attachment unit interface
<b>ayt</b>	are you there
<b>BAN</b>	Boundary Access Node
<b>BBCM</b>	Bridging Broadcast Manager
<b>BECN</b>	backward explicit congestion notification
<b>BGP</b>	Border Gateway Protocol
<b>BNC</b>	bayonet Niell-Concelman
<b>BNCP</b>	Bridging Network Control Protocol
<b>BOOTP</b>	BOOT protocol
<b>BPDU</b>	bridge protocol data unit
<b>bps</b>	bits per second
<b>BR</b>	bridging/routing
<b>BRS</b>	bandwidth reservation
<b>BSD</b>	Berkeley software distribution

**BTP** BOOTP relay agent  
**BTU** basic transmission unit  
**CAM** content-addressable memory  
**CCITT** Consultative Committee on International Telegraph and Telephone  
**CD** collision detection  
**CGWCON**  
Gateway Console  
**CIDR** Classless Inter-Domain Routing  
**CIP** Classical IP  
**CIR** committed information rate  
**CLNP** Connectionless-Mode Network Protocol  
**CPU** central processing unit  
**CRC** cyclic redundancy check  
**CRS** configuration report server  
**CTS** clear to send  
**CUD** call user data  
**DAF** destination address filtering  
**DB** database  
**DBsum**  
database summary  
**DCD** data channel received line signal detector  
**DCE** data circuit-terminating equipment  
**DCS** Directly connected server  
**DDLC** dual data-link controller  
**DDN** Defense Data Network  
**DDP** Datagram Delivery Protocol  
**DDT** Dynamic Debugging Tool  
**DHCP** Dynamic Host Configuration Protocol  
**dir** directly connected  
**DL** data link  
**DLC** data link control  
**DLCI** data link connection identifier  
**DLS** data link switching  
**DLSw** data link switching  
**DMA** direct memory access  
**DNA** Digital Network Architecture  
**DNCP** DECnet Protocol Control Protocol  
**DNIC** Data Network Identifier Code

**DoD** Department of Defense  
**DOS** Disk Operating System  
**DR** designated router  
**DRAM** Dynamic Random Access Memory  
**DSAP** destination service access point  
**DSE** data switching equipment  
**DSE** data switching exchange  
**DSR** data set ready  
**DSU** data service unit  
**DTE** data terminal equipment  
**DTR** data terminal ready  
**Dtype** destination type  
**DVMRP**  
     Distance Vector Multicast Routing Protocol  
**E&M** Ear & Mouth  
**E1** 2.048 Mbps transmission rate  
**EDEL** end delimiter  
**EDI** error detected indicator  
**EGP** Exterior Gateway Protocol  
**EIA** Electronics Industries Association  
**ELAN** Emulated LAN  
**ELAP** EtherTalk Link Access Protocol  
**ELS** Event Logging System  
**ELSCon**  
     Secondary ELS Console  
**ESI** End system identifier  
**EST** Eastern Standard Time  
**Eth** Ethernet  
**fa-ga** functional address-group address  
**FCS** frame check sequence  
**FECN** forward explicit congestion notification  
**FIFO** first in, first out  
**FLT** filter library  
**FR** Frame Relay  
**FRL** Frame Relay  
**FTP** File Transfer Protocol  
**FXO** Foreign Exchange Office  
**FXS** Foreign Exchange Station

<b>GMT</b>	Greenwich Mean Time
<b>GOSIP</b>	Government Open Systems Interconnection Profile
<b>GTE</b>	General Telephone Company
<b>GWCON</b>	Gateway Console
<b>HDLC</b>	high-level data link control
<b>HEX</b>	hexadecimal
<b>HPR</b>	high-performance routing
<b>HST</b>	TCP/IP host services
<b>HTF</b>	host table format
<b>IBD</b>	Integrated Boot Device
<b>ICMP</b>	Internet Control Message Protocol
<b>ICP</b>	Internet Control Protocol
<b>ID</b>	identification
<b>IDP</b>	Initial Domain Part
<b>IDP</b>	Internet Datagram Protocol
<b>IEEE</b>	Institute of Electrical and Electronics Engineers
<b>Ifc#</b>	interface number
<b>IGP</b>	interior gateway protocol
<b>InARP</b>	Inverse Address Resolution Protocol
<b>IP</b>	Internet Protocol
<b>IPCP</b>	IP Control Protocol
<b>IPPN</b>	IP Protocol Network
<b>IPX</b>	Internetwork Packet Exchange
<b>IPXCP</b>	IPX Control Protocol
<b>ISDN</b>	integrated services digital network
<b>ISO</b>	International Organization for Standardization
<b>Kbps</b>	kilobits per second
<b>LAN</b>	local area network
<b>LAPB</b>	link access protocol-balanced
<b>LAT</b>	local area transport
<b>LCS</b>	LAN Channel Station
<b>LCP</b>	Link Control Protocol
<b>LED</b>	light-emitting diode
<b>LF</b>	largest frame; line feed
<b>LIS</b>	Logical IP subnet
<b>LLC</b>	logical link control

<b>LLC2</b>	logical link control 2
<b>LMI</b>	local management interface
<b>LRM</b>	LAN reporting mechanism
<b>LS</b>	link state
<b>LSA</b>	link state advertisement
<b>LSA</b>	Link Services Architecture
<b>LSB</b>	least significant bit
<b>LSI</b>	LAN shortcuts interface
<b>LSreq</b>	link state request
<b>LSrxl</b>	link state retransmission list
<b>LU</b>	logical unit
<b>MAC</b>	medium access control
<b>Mb</b>	megabit
<b>MB</b>	megabyte
<b>Mbps</b>	megabits per second
<b>MBps</b>	megabytes per second
<b>MC</b>	multicast
<b>MCF</b>	MAC filtering
<b>MIB</b>	Management Information Base
<b>MIB II</b>	Management Information Base II
<b>MILNET</b>	military network
<b>MOS</b>	Micro Operating System
<b>MOSDBG</b>	Micro Operating System Debugging Tool
<b>MOSPF</b>	Open Shortest Path First with multicast extensions
<b>MPC</b>	Multi-Path Channel
<b>MPC+</b>	High performance data transfer (HPDT) Multi-Path Channel
<b>MSB</b>	most significant bit
<b>MSDU</b>	MAC service data unit
<b>MRU</b>	maximum receive unit
<b>MTU</b>	maximum transmission unit
<b>nak</b>	not acknowledged
<b>NAS</b>	Nways Switch Administration station
<b>NBMA</b>	Non-Broadcast Multiple Access
<b>NBP</b>	Name Binding Protocol
<b>NBR</b>	neighbor

**NCP** Network Control Protocol  
**NCP** Network Core Protocol  
**NDPS** non-disruptive path switching  
**NetBIOS**  
Network Basic Input/Output System  
**NHRP** Next Hop Resolution Protocol  
**NIST** National Institute of Standards and Technology  
**NPDU** Network Protocol Data Unit  
**NRZ** non-return-to-zero  
**NRZI** non-return-to-zero inverted  
**NSAP** Network Service Access Point  
**NSF** National Science Foundation  
**NSFNET**  
National Science Foundation NETwork  
**NVCNFG**  
nonvolatile configuration  
**OOS** Out of Service  
**OPCON**  
Operator Console  
**OSI** open systems interconnection  
**OSICP**  
OSI Control Protocol  
**OSPF** Open Shortest Path First  
**OUI** organization unique identifier  
**PC** personal computer  
**PCR** peak cell rate  
**PDN** public data network  
**PING** Packet internet groper  
**PDU** protocol data unit  
**PID** process identification  
**P-P** Point-to-Point  
**PPP** Point-to-Point Protocol  
**PROM** programmable read-only memory  
**PU** physical unit  
**PVC** permanent virtual circuit  
**RAM** random access memory  
**RD** route descriptor  
**REM** ring error monitor  
**REV** receive

**RFC** Request for Comments  
**RI** ring indicator; routing information  
**RIF** routing information field  
**RII** routing information indicator  
**RIP** Routing Information Protocol  
**RISC** reduced instruction-set computer  
**RNR** receive not ready  
**ROM** read-only memory  
**ROpcon** Remote Operator Console  
**RPS** ring parameter server  
**RTMP** Routing Table Maintenance Protocol  
**RTP** RouTing update Protocol  
**RTS** request to send  
**Rtype** route type  
**rxmits** retransmissions  
**rxmt** retransmit  
**s** second  
**SAF** source address filtering  
**SAP** service access point  
**SAP** Service Advertising Protocol  
**SCR** Sustained cell rate  
**SCSP** Server Cache Synchronization Protocol  
**sdel** start delimiter  
**SDLC** SDLC relay, synchronous data link control  
**seqno** sequence number  
**SGID** sever group id  
**SGMP** Simple Gateway Monitoring Protocol  
**SL** serial line  
**SMP** standby monitor present  
**SMTP** Simple Mail Transfer Protocol  
**SNA** Systems Network Architecture  
**SNAP** Subnetwork Access Protocol  
**SNMP** Simple Network Management Protocol  
**SNPA** subnetwork point of attachment  
**SPF** OSPF intra-area route  
**SPE1** OSPF external route type 1  
**SPE2** OSPF external route type 2

<b>SPIA</b>	OSPF inter-area route type
<b>SPID</b>	service profile ID
<b>SPX</b>	Sequenced Packet Exchange
<b>SQE</b>	signal quality error
<b>SRAM</b>	static random access memory
<b>SRB</b>	source routing bridge
<b>SRF</b>	specifically routed frame
<b>SRLY</b>	SDLC relay
<b>SRT</b>	source routing transparent
<b>SR-TB</b>	source routing-transparent bridge
<b>STA</b>	static
<b>STB</b>	spanning tree bridge
<b>STE</b>	spanning tree explorer
<b>STP</b>	shielded twisted pair; spanning tree protocol
<b>SVC</b>	switched virtual circuit
<b>TB</b>	transparent bridge
<b>TCN</b>	topology change notification
<b>TCP</b>	Transmission Control Protocol
<b>TCP/IP</b>	Transmission Control Protocol/Internet Protocol
<b>TEI</b>	terminal point identifier
<b>TFTP</b>	Trivial File Transfer Protocol
<b>TKR</b>	token ring
<b>TMO</b>	timeout
<b>TOS</b>	type of service
<b>TSF</b>	transparent spanning frames
<b>TTL</b>	time to live
<b>TTY</b>	teletypewriter
<b>TX</b>	transmit
<b>UA</b>	unnumbered acknowledgment
<b>UDP</b>	User Datagram Protocol
<b>UI</b>	unnumbered information
<b>UTP</b>	unshielded twisted pair
<b>VCC</b>	Virtual Channel Connection
<b>VINES</b>	Virtual NEtworking System
<b>VIR</b>	variable information rate
<b>VL</b>	virtual link



<b>VNI</b>	Virtual Network Interface
<b>VoFR</b>	Voice over Frame Relay
<b>VR</b>	virtual route
<b>WAN</b>	wide area network
<b>WRS</b>	WAN restoral/reroute
<b>X.25</b>	packet-switched networks
<b>X.251</b>	X.25 physical layer
<b>X.252</b>	X.25 frame layer
<b>X.253</b>	X.25 packet layer
<b>XID</b>	exchange identification
<b>XNS</b>	Xerox Network Systems
<b>XSUM</b>	checksum
<b>ZIP</b>	AppleTalk Zone Information Protocol
<b>ZIP2</b>	AppleTalk Zone Information Protocol 2
<b>ZIT</b>	Zone Information Table



---

## Glossary

This glossary includes terms and definitions from:

- The *American National Standard Dictionary for Information Systems*, ANSI X3.172-1990, copyright 1990 by the American National Standards Institute (ANSI). Copies may be purchased from the American National Standards Institute, 11 West 42nd Street, New York, New York 10036. Definitions are identified by the symbol (A) after the definition.
- The ANSI/EIA Standard—440-A, *Fiber Optic Terminology* Copies may be purchased from the Electronic Industries Association, 2001 Pennsylvania Avenue, N.W., Washington, DC 20006. Definitions are identified by the symbol (E) after the definition.
- The *Information Technology Vocabulary* developed by Subcommittee 1, Joint Technical Committee 1, of the International Organization for Standardization and the International Electrotechnical Commission (ISO/IEC JTC1/SC1). Definitions of published parts of this vocabulary are identified by the symbol (I) after the definition; definitions taken from draft international standards, committee drafts, and working papers being developed by ISO/IEC JTC1/SC1 are identified by the symbol (T) after the definition, indicating that final agreement has not yet been reached among the participating National Bodies of SC1.
- The *IBM Dictionary of Computing*, New York: McGraw-Hill, 1994.
- Internet Request for Comments: 1208, *Glossary of Networking Terms*
- Internet Request for Comments: 1392, *Internet Users' Glossary*
- The *Object-Oriented Interface Design: IBM Common User Access Guidelines*, Carmel, Indiana: Que, 1992.

The following cross-references are used in this glossary:

### Contrast with:

This refers to a term that has an opposed or substantively different meaning.

### Synonym for:

This indicates that the term has the same meaning as a preferred term, which is defined in its proper place in the glossary.

### Synonymous with:

This is a backward reference from a defined term to all other terms that have the same meaning.

**See:** This refers the reader to multiple-word terms that have the same last word.

### See also:

This refers the reader to terms that have a related, but not synonymous, meaning.

## A

**abstract syntax.** A data specification that includes all distinctions that are needed in data transmissions, but that omits (abstracts) other details such as those that depend on specific computer architectures. See also *abstract syntax notation 1 (ASN.1)* and *basic encoding rules (BER)*.

**abstract syntax notation 1 (ASN.1).** The Open Systems Interconnection (OSI) method for abstract syntax specified in the following standards:

- ITU-T Recommendation X.208 (1988) | ISO/IEC 8824: 1990
- ITU-T Recommendation X.680 (1994) | ISO/IEC 8824-1: 1994

See also *basic encoding rules (BER)*.

**ACCESS.** In the Simple Network Management Protocol (SNMP), the clause in a Management Information Base (MIB) module that defines the minimum level of support that a managed node provides for an object.

**acknowledgment.** (1) The transmission, by a receiver, of acknowledge characters as an affirmative response to a sender. (T) (2) An indication that an item sent was received.

**active.** (1) Operational. (2) Pertaining to a node or device that is connected or is available for connection to another node or device.

**active monitor.** In a token-ring network, a function performed at any one time by one ring station that initiates the transmission of tokens and provides token error recovery facilities. Any active adapter on the ring has the ability to provide the active monitor function if the current active monitor fails.

**address.** In data communication, the unique code assigned to each device, workstation, or user connected to a network.

**address mapping table (AMT).** A table, maintained within the AppleTalk router, that provides a current mapping of node addresses to hardware addresses.

**address mask.** For internet subnetting, a 32-bit mask used to identify the subnetwork address bits in the host portion of an IP address. Synonymous with *subnet mask* and *subnetwork mask*.

**address resolution.** (1) A method for mapping network-layer addresses to media-specific addresses. (2) See also *Address Resolution Protocol (ARP)* and *AppleTalk Address Resolution Protocol (AARP)*.

**Address Resolution Protocol (ARP).** (1) In the Internet suite of protocols, the protocol that dynamically maps an IP address to an address used by a supporting metropolitan or local area network such as Ethernet or token-ring. (2) See also *Reverse Address Resolution Protocol (RARP)*.

**addressing.** In data communication, the way in which a station selects the station to which it is to send data.

**adjacent nodes.** Two nodes connected together by at least one path that connects no other node. (T)

**Administrative Domain.** A collection of hosts and routers, and the interconnecting networks, managed by a single administrative authority.

**Advanced Peer-to-Peer Networking (APPN).** An extension to SNA featuring (a) greater distributed network control that avoids critical hierarchical dependencies, thereby isolating the effects of single points of failure; (b) dynamic exchange of network topology information to foster ease of connection, reconfiguration, and adaptive route selection; (c) dynamic definition of network resources; and (d) automated resource registration and directory lookup. APPN extends the LU 6.2 peer orientation for end-user services to network control and supports multiple LU types, including LU 2, LU 3, and LU 6.2.

**Advanced Peer-to-Peer Networking (APPN) end node.** A node that provides a broad range of end-user services and supports sessions between its local control point (CP) and the CP in an adjacent network node. It uses these sessions to dynamically register its resources with the adjacent CP (its network node server), to send and receive directory search requests, and to obtain management services. An APPN end node can also attach to a subarea network as a peripheral node or to other end nodes.

**Advanced Peer-to-Peer Networking (APPN) network.** A collection of interconnected network nodes and their client end nodes.

**Advanced Peer-to-Peer Networking (APPN) network node.** A node that offers a broad range of end-user services and that can provide the following:

- Distributed directory services, including registration of its domain resources to a central directory server
- Topology database exchanges with other APPN network nodes, enabling network nodes throughout the network to select optimal routes for LU-LU sessions based on requested classes of service
- Session services for its local LUs and client end nodes
- Intermediate routing services within an APPN network

**Advanced Peer-to-Peer Networking (APPN) node.** An APPN network node or an APPN end node.

**agent.** A system that assumes an agent role.

**alert.** A message sent to a management services focal point in a network to identify a problem or an impending problem.

**all-stations address.** In communications, synonym for *broadcast address*.

**American National Standards Institute (ANSI).** An organization consisting of producers, consumers, and general interest groups, that establishes the procedures by which accredited organizations create and maintain voluntary industry standards in the United States. (A)

**analog.** (1) Pertaining to data consisting of continuously variable physical quantities. (A) (2) Contrast with *digital*.

**AppleTalk.** A network protocol developed by Apple Computer, Inc. This protocol is used to interconnect network devices, which can be a mixture of Apple and non-Apple products.

**AppleTalk Address Resolution Protocol (AARP).** In AppleTalk networks, a protocol that (a) translates AppleTalk node addresses into hardware addresses and (b) reconciles addressing discrepancies in networks that support more than one set of protocols.

**AppleTalk Transaction Protocol (ATP).** In AppleTalk networks, a protocol that provides client/server request and response functions for hosts accessing the Zone Information Protocol (ZIP) for zone information.

**APPN network.** See *Advanced Peer-to-Peer Networking (APPN) network*.

**APPN network node.** See *Advanced Peer-to-Peer Networking (APPN) network node*.

**arbitrary MAC addressing (AMA).** In DECnet architecture, an addressing scheme used by DECnet Phase IV-Prime that supports universally administered addresses and locally administered addresses.

**area.** In Internet and DECnet routing protocols, a subset of a network or gateway grouped together by

definition of the network administrator. Each area is self-contained; knowledge of an area's topology remains hidden from other areas.

**asynchronous (ASYNCR).** Pertaining to two or more processes that do not depend upon the occurrence of specific events such as common timing signals. (T)

**attachment unit interface (AUI).** In a local area network, the interface between the medium attachment unit and the data terminal equipment within a data station. (I) (A)

**authentication failure.** In the Simple Network Management Protocol (SNMP), a trap that may be generated by an authentication entity when a requesting client is not a member of the SNMP community.

**autonomous system.** In TCP/IP, a group of networks and routers under one administrative authority. These networks and routers cooperate closely to propagate network reachability (and routing) information among themselves using an interior gateway protocol of their choice.

**autonomous system number.** In TCP/IP, a number assigned to an autonomous system by the same central authority that also assigns IP addresses. The autonomous system number makes it possible for automated routing algorithms to distinguish autonomous systems.

## B

**backbone.** (1) In a local area network multiple-bridge ring configuration, a high-speed link to which the rings are connected by means of bridges or routers. A backbone may be configured as a bus or as a ring. (2) In a wide area network, a high-speed link to which nodes or data switching exchanges (DSEs) are connected.

**backbone network.** A central network to which smaller networks, normally of lower speed, connect. The backbone network usually has a much higher capacity than the networks it helps interconnect or is a wide-area network (WAN) such as a public packet-switched datagram network.

**backbone router.** (1) A router used to transmit data between areas. (2) One in a series of routers that is used to interconnect networks into a larger internet.

**Bandwidth.** The bandwidth of an optical link designates the information-carrying capacity of the link and is related to the maximum bit rate that a fiber link can support.

**basic transmission unit (BTU).** In SNA, the unit of data and control information passed between path control components. A BTU can consist of one or more path information units (PIUs).

**baud.** In asynchronous transmission, the unit of modulation rate corresponding to one unit interval per second; that is, if the duration of the unit interval is 20 milliseconds, the modulation rate is 50 baud. (A)

**bootstrap.** (1) A sequence of instructions whose execution causes additional instructions to be loaded and executed until the complete computer program is in storage. (T) (2) A technique or device designed to bring itself into a desired state by means of its own action, for example, a machine routine whose first few instructions are sufficient to bring the rest of itself into the computer from an input device. (A)

**Border Gateway Protocol (BGP).** An Internet Protocol (IP) routing protocol used between domains and autonomous systems.

**border router.** In Internet communications, a router, positioned at the edge of an autonomous system, that communicates with a router that is positioned at the edge of a different autonomous system.

**bridge.** A functional unit that interconnects multiple LANs (locally or remotely) that use the same logical link control protocol but that can use different medium access control protocols. A bridge forwards a frame to another bridge based on the medium access control (MAC) address.

**bridge identifier.** An 8-byte field, used in a spanning tree protocol, composed of the MAC address of the port with the lowest port identifier and a user-defined value.

**bridging.** In LANs, the forwarding of a frame from one LAN segment to another. The destination is specified by the medium access control (MAC) sublayer address encoded in the destination address field of the frame header.

**broadcast.** (1) Transmission of the same data to all destinations. (T) (2) Simultaneous transmission of data to more than one destination. (3) Contrast with *multicast*.

**broadcast address.** In communications, a station address (eight 1's) reserved as an address common to all stations on a link. Synonymous with *all-stations address*.

## C

**cache.** (1) A special-purpose buffer storage, smaller and faster than main storage, used to hold a copy of instructions and data obtained from main storage and likely to be needed next by the processor. (T) (2) A buffer storage that contains frequently accessed instructions and data; it is used to reduce access time. (3) An optional part of the directory database in network nodes where frequently used directory information may be stored to speed directory searches. (4) To place, hide, or store in a cache.

**call request packet.** (1) A call supervision packet that a data terminal equipment (DTE) transmits to ask that a connection for a call be established throughout the network. (2) In X.25 communications, a call supervision packet transmitted by a DTE to ask for a call establishment through the network.

**canonical address.** In LANs, the IEEE 802.1 format for the transmission of medium access control (MAC) addresses for token-ring and Ethernet adapters. In canonical format, the least significant (rightmost) bit of each address byte is transmitted first. Contrast with *noncanonical address*.

**carrier.** An electric or electromagnetic wave or pulse train that may be varied by a signal bearing information to be transmitted over a communication system. (T)

**carrier detect.** Synonym for *received line signal detector (RLSD)*.

**carrier sense.** In a local area network, an ongoing activity of a data station to detect whether another station is transmitting. (T)

**carrier sense multiple access with collision detection (CSMA/CD).** A protocol that requires carrier sense and in which a transmitting data station that detects another signal while transmitting, stops sending, sends a jam signal, and then waits for a variable time before trying again. (T) (A)

**CCITT.** International Telegraph and Telephone Consultative Committee. This was an organization of the International Telecommunication Union (ITU). On 1 March 1993 the ITU was reorganized, and responsibilities for standardization were placed in a subordinate organization named the Telecommunication Standardization Sector of the Telecommunication Union (ITU-TS). "CCITT" continues to be used for recommendations that were approved before the reorganization.

**channel.** (1) A path along which signals can be sent, for example, data channel, output channel. (A) (2) A functional unit, controlled by the processor, that handles the transfer of data between processor storage and local peripheral equipment.

**channel service unit (CSU).** A unit that provides the interface to a digital network. The CSU provides line conditioning (or equalization) functions, which keep the signal's performance consistent across the channel bandwidth; signal reshaping, which constitutes the binary pulse stream; and loopback testing, which includes the transmission of test signals between the CSU and the network carrier's office channel unit. See also *data service unit (DSU)*.

**channelization.** The process of breaking the bandwidth on a communication line into a number of channels, possibly of different size. Also called *time division multiplexing (TDM)*.

**checksum.** (1) The sum of a group of data associated with the group and used for checking purposes. (T) (2) In error detection, a function of all bits in a block. If the written and calculated sums do not agree, an error is indicated. (3) On a diskette, data written in a sector for error detection purposes; a calculated checksum that does not match the checksum of data written in the sector indicates a bad sector. The data are either numeric or other character strings regarded as numeric for the purpose of calculating the checksum.

**circuit switching.** (1) A process that, on demand, connects two or more data terminal equipment (DTEs) and permits the exclusive use of a data circuit between them until the connection is released. (I) (A) (2) Synonymous with *line switching*.

**class A network.** In Internet communications, a network in which the high-order (most significant) bit of the IP address is set to 0 and the host ID occupies the three low-order octets.

**class B network.** In Internet communications, a network in which the two high-order (most significant and next-to-most significant) bits of the IP address are set to 1 and 0, respectively, and the host ID occupies the two low-order octets.

**class of service (COS).** A set of characteristics (such as route security, transmission priority, and bandwidth) used to construct a route between session partners. The class of service is derived from a mode name specified by the initiator of a session.

**client.** (1) A functional unit that receives shared services from a server. (T) (2) A user.

**client/server.** In communications, the model of interaction in distributed data processing in which a program at one site sends a request to a program at another site and awaits a response. The requesting program is called a client; the answering program is called a server.

**clocking.** (1) In binary synchronous communication, the use of clock pulses to control synchronization of data and control characters. (2) A method of controlling the number of data bits sent on a telecommunication line in a given time.

**collision.** An unwanted condition that results from concurrent transmissions on a channel. (T)

**collision detection.** In carrier sense multiple access with collision detection (CSMA/CD), a signal indicating that two or more stations are transmitting simultaneously.

**Committed information rate.** The maximum amount of data in bits that the network agrees to deliver.

**community.** In the Simple Network Management Protocol (SNMP), an administrative relationship between entities.

**community name.** In the Simple Network Management Protocol (SNMP), a string of octets identifying a community.

**compression.** (1) The process of eliminating gaps, empty fields, redundancies, and unnecessary data to shorten the length of records or blocks. (2) Any encoding to reduce the number of bits used to represent a given message or record.

**configuration.** (1) The manner in which the hardware and software of an information processing system are organized and interconnected. (T) (2) The devices and programs that make up a system, subsystem, or network.

**configuration database (CDB).** A database that stores the configuration parameters of one or several devices. It is prepared and updated using the configuration program.

**configuration file.** A file that specifies the characteristics of a system device or network.

**configuration parameter.** A variable in a configuration definition, the values of which can characterize the relationship of a product to other products in the same network or can define characteristics of the product itself.

**configuration report server (CRS).** In the IBM Token-Ring Network Bridge Program, the server that accepts commands from the LAN Network Manager (LNM) to get station information, set station parameters, and remove stations on its ring. This server also collects and forwards configuration reports generated by stations on its ring. The configuration reports include the new active monitor reports and the nearest active upstream neighbor (NAUN) reports.

**congestion.** See *network congestion*.

**connection.** In data communication, an association established between functional units for conveying information. (I) (A)

**control point (CP).** (1) A component of an APPN or LEN node that manages the resources of that node. In an APPN node, the CP is capable of engaging in CP-CP sessions with other APPN nodes. In an APPN network node, the CP also provides services to adjacent end nodes in the APPN network. (2) A component of a node that manages resources of that node and optionally provides services to other nodes in the network. Examples are a system services control point (SSCP) in a type 5 subarea node, a network node control point (NNCP) in an APPN network node, and an

end node control point (ENCP) in an APPN or LEN end node. An SSCP and an NNCP can provide services to other nodes.

**control point management services (CPMS).** A component of a control point, consisting of management services function sets, that provides facilities to assist in performing problem management, performance and accounting management, change management, and configuration management. Capabilities provided by the CPMS include sending requests to physical unit management services (PUMS) to test system resources, collecting statistical information (for example, error and performance data) from PUMS about the system resources, and analyzing and presenting test results and statistical information collected about the system resources. Analysis and presentation responsibilities for problem determination and performance monitoring can be distributed among multiple CPMSs.

**control point management services unit (CP-MSU).** The message unit that contains management services data and flows between management services function sets. This message unit is in general data stream (GDS) format. See also *management services unit (MSU)* and *network management vector transport (NMVT)*.

## D

**D-bit.** Delivery-confirmation bit. In X.25 communications, the bit in a data packet or call-request packet that is set to 1 if end-to-end acknowledgment (delivery confirmation) is required from the recipient.

**daemon.** A program that runs unattended to perform a standard service. Some daemons are triggered automatically to perform their task; others operate periodically.

**data carrier detect (DCD).** Synonym for *received line signal detector (RLSD)*.

**data circuit.** (1) A pair of associated transmit and receive channels that provide a means of two-way data communication. (I) (2) In SNA, synonym for *link connection*. (3) See also *physical circuit* and *virtual circuit*.

### Notes:

1. Between data switching exchanges, the data circuit may include data circuit-terminating equipment (DCE), depending on the type of interface used at the data switching exchange.
2. Between a data station and a data switching exchange or data concentrator, the data circuit includes the data circuit-terminating equipment at the data station end, and may include equipment similar to a DCE at the data switching exchange or data concentrator location.

**data circuit-terminating equipment (DCE).** In a data station, the equipment that provides the signal

conversion and coding between the data terminal equipment (DTE) and the line. (I)

**Notes:**

1. The DCE may be separate equipment or an integral part of the DTE or of the intermediate equipment.
2. A DCE may perform other functions that are usually performed at the network end of the line.

**data link connection identifier (DLCI).** The numeric identifier of a frame-relay subport or PVC segment in a frame-relay network. Each subport in a single frame-relay port has a unique DLCI. The following table, excerpted from the American National Standards Institute (ANSI) Standard T1.618 and the International Telegraph and Telephone Consultative Committee (ITU-T/CCITT) Standard Q.922, indicates the functions associated with certain DLCI values:

DLCI Values	Function
0	in-channel signaling
1–15	reserved
16–991	assigned using frame-relay connection procedures
992–1007	Layer 2 management of frame-relay bearer service
1008–1022	reserved
1023	in-channel layer management

**data link control (DLC).** A set of rules used by nodes on a data link (such as an SDLC link or a token ring) to accomplish an orderly exchange of information.

**data link control (DLC) layer.** In SNA, the layer that consists of the link stations that schedule data transfer over a link between two nodes and perform error control for the link. Examples of data link control are SDLC for serial-by-bit link connection and data link control for the System/370 channel.

**Note:** The DLC layer is usually independent of the physical transport mechanism and ensures the integrity of data that reaches the higher layers.

**data link layer.** In the Open Systems Interconnection reference model, the layer that provides services to transfer data between entities in the network layer over a communication link. The data link layer detects and possibly corrects errors that may occur in the physical layer. (T)

**data link level.** (1) In the hierarchical structure of a data station, the conceptual level of control or processing logic between high level logic and the data link that maintains control of the data link. The data link level performs such functions as inserting transmit bits and deleting receive bits; interpreting address and control fields; generating, transmitting, and interpreting commands and responses; and computing and

interpreting frame check sequences. See also *packet level* and *physical level*. (2) In X.25 communications, synonym for *frame level*.

**data link switching (DLSw).** A method of transporting network protocols that use IEEE 802.2 logical link control (LLC) type 2. SNA and NetBIOS are examples of protocols that use LLC type 2. See also *encapsulation* and *spoofing*.

**data packet.** In X.25 communications, a packet used for the transmission of user data on a virtual circuit at the DTE/DCE interface.

**data service unit (DSU).** A device that provides a digital data service interface directly to the data terminal equipment. The DSU provides loop equalization, remote and local testing capabilities, and a standard EIA/CCITT interface.

**data set ready (DSR).** Synonym for *DCE ready*.

**data switching exchange (DSE).** The equipment installed at a single location to provide switching functions, such as circuit switching, message switching, and packet switching. (I)

**data terminal equipment (DTE).** That part of a data station that serves as a data source, data sink, or both. (I) (A)

**data terminal ready (DTR).** A signal to the modem used with the EIA 232 protocol.

**data transfer rate.** The average number of bits, characters, or blocks per unit time passing between corresponding equipment in a data transmission system. (I)

**Notes:**

1. The rate is expressed in bits, characters, or blocks per second, minute, or hour.
2. Corresponding equipment should be indicated; for example, modems, intermediate equipment, or source and sink.

**datagram.** (1) In packet switching, a self-contained packet, independent of other packets, that carries information sufficient for routing from the originating data terminal equipment (DTE) to the destination DTE without relying on earlier exchanges between the DTEs and the network. (I) (2) In TCP/IP, the basic unit of information passed across the Internet environment. A datagram contains a source and destination address along with the data. An Internet Protocol (IP) datagram consists of an IP header followed by the transport layer data. (3) See also *packet* and *segment*.

**Datagram Delivery Protocol (DDP).** In AppleTalk networks, a protocol that provides network connectivity by means of connectionless socket-to-socket delivery service on the internet layer.



**DCE ready.** In the EIA 232 standard, a signal that indicates to the data terminal equipment (DTE) that the local data circuit-terminating equipment (DCE) is connected to the communication channel and is ready to send data. Synonymous with *data set ready (DSR)*.

**DECnet.** A network architecture that defines the operation of a family of software modules, databases, and hardware components typically used to tie Digital Equipment Corporation systems together for resource sharing, distributed computation, or remote system configuration. DECnet network implementations follow the Digital Network Architecture (DNA) model.

**default.** Pertaining to an attribute, condition, value, or option that is assumed when none is explicitly specified. (I)

**dependent LU requester (DLUR).** An APPN end node or an APPN network node that owns dependent LUs, but requests that a dependent LU server provide the SSCP services for those dependent LUs.

**designated router.** A router that informs end nodes of the existence and identity of other routers. The selection of the designated router is based upon the router with the highest priority. When several routers share the highest priority, the router with the highest station address is selected.

**destination node.** The node to which a request or data is sent.

**destination port.** The 8-port asynchronous adapter that serves as a connection point with a serial service.

**destination service access point (DSAP).** In SNA and TCP/IP, a logical address that allows a system to route data from a remote device to the appropriate communications support. Contrast with *source service access point (SSAP)*.

**device.** A mechanical, electrical, or electronic contrivance with a specific purpose.

**digital.** (1) Pertaining to data that consist of digits. (T) (2) Pertaining to data in the form of digits. (A) (3) Contrast with *analog*.

**Digital Network Architecture (DNA).** The model for all DECnet hardware and software implementations.

**direct memory access (DMA).** The system facility that allows a device on the Micro Channel bus to get direct access to the system or bus memory without the intervention of the system processor.

**directory.** A table of identifiers and references to the corresponding items of data. (I) (A)

**directory service (DS).** An application service element that translates the symbolic names used by application processes into the complete network addresses used in an OSI environment. (T)

**directory services (DS).** A control point component of an APPN node that maintains knowledge of the location of network resources.

**disable.** To make nonfunctional.

**disabled.** (1) Pertaining to a state of a processing unit that prevents the occurrence of certain types of interruptions. (2) Pertaining to the state in which a transmission control unit or audio response unit cannot accept incoming calls on a line.

**domain.** (1) That part of a computer network in which the data processing resources are under common control. (T) (2) In Open Systems Interconnection (OSI), a part of a distributed system or a set of managed objects to which a common policy applies. (3) See *Administrative Domain* and *domain name*.

**domain name.** In the Internet suite of protocols, a name of a host system. A domain name consists of a sequence of subnames separated by a delimiter character. For example, if the fully qualified domain name (FQDN) of a host system is *ralvm7.vnet.ibm.com*, each of the following is a domain name:

- *ralvm7.vnet.ibm.com*
- *vnet.ibm.com*
- *ibm.com*

**domain name server.** In the Internet suite of protocols, a server program that supplies name-to-address translation by mapping domain names to IP addresses. Synonymous with *name server*.

**Domain Name System (DNS).** In the Internet suite of protocols, the distributed database system used to map domain names to IP addresses.

**dotted decimal notation.** The syntactical representation for a 32-bit integer that consists of four 8-bit numbers written in base 10 with periods (dots) separating them. It is used to represent IP addresses.

**dump.** (1) Data that has been dumped. (T) (2) To copy the contents of all or part of virtual storage for the purpose of collecting error information.

**dynamic reconfiguration (DR).** The process of changing the network configuration (peripheral PUs and LUs) without regenerating complete configuration tables or deactivating the affected major node.

**Dynamic Routing.** Routing using learned routes rather than routes statically configured at initialization.

## E

**echo.** In data communication, a reflected signal on a communications channel. For example, on a communications terminal, each signal is displayed twice, once when entered at the local terminal and again when returned over the communications link. This allows the signals to be checked for accuracy.

**EIA 232.** In data communication, a specification of the Electronic Industries Association (EIA) that defines the interface between data terminal equipment (DTE) and data circuit-terminating equipment (DCE), using serial binary data interchange.

**Electronic Industries Association (EIA).** An organization of electronics manufacturers that advances the technological growth of the industry, represents the views of its members, and develops industry standards.

**EIA unit.** A unit of measure, established by the Electronic Industries Association, equal to 44.45 millimeters (1.75 inches).

**encapsulation.** (1) In communications, a technique used by layered protocols by which a layer adds control information to the protocol data unit (PDU) from the layer it supports. In this respect, the layer encapsulates the data from the supported layer. In the Internet suite of protocols, for example, a packet would contain control information from the physical layer, followed by control information from the network layer, followed by the application protocol data. (2) See also *data link switching*.

**encode.** To convert data by the use of a code in such a manner that reconversion to the original form is possible. (T)

**end node (EN).** (1) See *Advanced Peer-to-Peer Networking (APPN) end node* and *low-entry networking (LEN) end node*. (2) In communications, a node that is frequently attached to a single data link and cannot perform intermediate routing functions.

**entry point (EP).** In SNA, a type 2.0, type 2.1, type 4, or type 5 node that provides distributed network management support. It sends network management data about itself and the resources it controls to a focal point for centralized processing, and it receives and executes focal-point initiated commands to manage and control its resources.

**Ethernet.** A 10-Mbps baseband local area network that allows multiple stations to access the transmission medium at will without prior coordination, avoids contention by using carrier sense and deference, and resolves contention by using collision detection and delayed retransmission. Ethernet uses carrier sense multiple access with collision detection (CSMA/CD).

**exception.** An abnormal condition such as an I/O error encountered in processing a data set or a file.

**exception response (ER).** In SNA, a protocol requested in the form-of-response-requested field of a request header that directs the receiver to return a response only if the request is unacceptable as received or cannot be processed; that is, a negative response, but not a positive response, can be returned. Contrast with *definite response* and *no response*.

**exchange identification (XID).** A specific type of basic link unit that is used to convey node and link characteristics between adjacent nodes. XIDs are exchanged between link stations before and during link activation to establish and negotiate link and node characteristics, and after link activation to communicate changes in these characteristics.

**explicit route (ER).** In SNA, a series of one or more transmission groups that connect two subarea nodes. An explicit route is identified by an origin subarea address, a destination subarea address, an explicit route number, and a reverse explicit route number. Contrast with *virtual route (VR)*.

**explorer frame.** See *explorer packet*.

**explorer packet.** In LANs, a packet that is generated by the source host and that traverses the entire source routing part of a LAN, gathering information on the possible paths available to the host.

**exterior gateway.** In Internet communications, a gateway on one autonomous system that communicates with another autonomous system. Contrast with *interior gateway*.

**Exterior Gateway Protocol (EGP).** In the Internet suite of protocols, a protocol, used between domains and autonomous systems, that enables network reachability information to be advertised and exchanged. IP network addresses in one autonomous system are advertised to another autonomous system by means of EGP-participating routers. An example of an EGP is the Border Gateway Protocol (BGP). Contrast with Interior Gateway Protocol (IGP).

## F

**fax.** Hardcopy received from a facsimile machine. Synonymous with *telecopy*.

**File Transfer Protocol (FTP).** In the Internet suite of protocols, an application layer protocol that uses TCP and Telnet services to transfer bulk-data files between machines or hosts.

**flash memory.** A data storage device that is programmable, erasable, and does not require continuous power. The chief advantage of flash memory over other programmable and erasable data storage

devices is that it can be reprogrammed without being removed from the circuit board.

**flow control.** (1) In SNA, the process of managing the rate at which data traffic passes between components of the network. The purpose of flow control is to optimize the rate of flow of message units with minimum congestion in the network; that is, to neither overflow the buffers at the receiver or at intermediate routing nodes, nor leave the receiver waiting for more message units. (2) See also  *pacing*.

**fragment.** See  *fragmentation*.

**fragmentation.** (1) The process of dividing a datagram into smaller parts, or fragments, to match the capabilities of the physical medium over which it is to be transmitted. (2) See also  *segmenting*.

**frame.** (1) In Open Systems Interconnection architecture, a data structure pertaining to a particular area of knowledge and consisting of slots that can accept the values of specific attributes and from which inferences can be drawn by appropriate procedural attachments. (T) (2) The unit of transmission in some local area networks, including the IBM Token-Ring Network. It includes delimiters, control characters, information, and checking characters. (3) In SDLC, the vehicle for every command, every response, and all information that is transmitted using SDLC procedures.

**frame level.** Synonymous with  *data link level*. See  *link level*.

**frame relay.** (1) An interface standard describing the boundary between a user's equipment and a fast-packet network. In frame-relay systems, flawed frames are discarded; recovery comes end-to-end rather than hop-by-hop. (2) A technique derived from the integrated services digital network (ISDN) D channel standard. It assumes that connections are reliable and dispenses with the overhead of error detection and control within the network.

**front-end processor.** A processor such as the IBM 3745 or 3174, that relieves a main frame from the communication control tasks.

## G

**gateway.** (1) A functional unit that interconnects two computer networks with different network architectures. A gateway connects networks or systems of different architectures. A bridge interconnects networks or systems with the same or similar architectures. (T) (2) In the IBM Token-Ring Network, a device and its associated software that connect a local area network to another local area network or a host that uses different logical link protocols. (3) In TCP/IP, synonym for  *router*.

**general data stream (GDS).** The data stream used for conversations in LU 6.2 sessions.

**general data stream (GDS) variable.** A type of RU substructure that is preceded by an identifier and a length field and includes either application data, user control data, or SNA-defined control data.

## H

**header.** (1) System-defined control information that precedes user data. (2) The portion of a message that contains control information for the message such as one or more destination fields, name of the originating station, input sequence number, character string indicating the type of message, and priority level for the message.

**heap memory.** The amount of RAM used to dynamically allocate data structures.

**Hello.** A protocol used by a group of cooperating, trusting routers to allow them to discover minimal delay routes.

**hello message.** (1) A message sent periodically to establish and test reachability between routers or between routers and hosts. (2) In the Internet suite of protocols, a message defined by the Hello protocol as an Interior Gateway Protocol (IGP).

**heuristic.** Pertaining to exploratory methods of problem solving in which solutions are discovered by evaluation of the progress made toward the final result.

**high-level data link control (HDLC).** In data communication, the use of a specified series of bits to control data links in accordance with the International Standards for HDLC: ISO 3309 Frame Structure and ISO 4335 Elements of Procedures.

**high-performance routing (HPR).** An addition to the Advanced Peer-to-Peer Networking (APPN) architecture that enhances data routing performance and reliability, especially when using high-speed links.

**hop.** (1) In APPN, a portion of a route that has no intermediate nodes. It consists of only a single transmission group connecting adjacent nodes. (2) To the routing layer, the logical distance between two nodes in a network.

**hop count.** (1) A metric or measure of distance between two points. (2) In Internet communications, the number of routers that a datagram passes through on its way to its destination. (3) In SNA, a measure of the number of links to be traversed in a path to a destination.

**host.** In the Internet suite of protocols, an end system. The end system can be any workstation; it does not have to be a mainframe.

**hub (intelligent).** A wiring concentrator, such as the IBM 8260, that provides bridging and routing functions for LANs with different cables and protocols.

**hysteresis.** The amount the temperature must change past the set alert threshold before the alert condition is cleared.

I

**I-frame.** Information frame.

**information (I) frame.** A frame in I format used for numbered information transfer.

**input/output channel.** In a data processing system, a functional unit that handles transfer of data between internal and peripheral equipment. (I) (A)

**Integrated Digital Network Exchange (IDNX).** A processor integrating voice, data, and image applications. It also manages the transmission resources, and connects to multiplexers and network management support systems. It allows integration of equipment from different vendors.

**integrated services digital network (ISDN).** A digital end-to-end telecommunication network that supports multiple services including, but not limited to, voice and data.

**Note:** ISDNs are used in public and private network architectures.

**interface.** (1) A shared boundary between two functional units, defined by functional characteristics, signal characteristics, or other characteristics, as appropriate. The concept includes the specification of the connection of two devices having different functions. (T) (2) Hardware, software, or both, that links systems, programs, or devices.

**interior gateway.** In Internet communications, a gateway that communicates only with its own autonomous system. Contrast with *exterior gateway*.

**Interior Gateway Protocol (IGP).** In the Internet suite of protocols, a protocol used to propagate network reachability and routing information within an autonomous system. Examples of IGPs are Routing Information Protocol (RIP) and Open Shortest Path First (OSPF).

**interleaving.** (1) The alternating of two or more operations or functions through the overlapped use of a computer facility. (2) In data transmission, the alternating of packets from one data stream with packets from another.

**intermediate node.** A node that is at the end of more than one branch. (T)

**intermediate session routing (ISR).** A type of routing function within an APPN network node that provides session-level flow control and outage reporting for all sessions that pass through the node but whose end points are elsewhere.

**International Organization for Standardization (ISO).** An organization of national standards bodies from various countries established to promote development of standards to facilitate international exchange of goods and services, and develop cooperation in intellectual, scientific, technological, and economic activity.

**International Telecommunication Union (ITU).** The specialized telecommunication agency of the United Nations, established to provide standardized communication procedures and practices, including frequency allocation and radio regulations worldwide.

**internet.** A collection of networks interconnected by a set of routers that allow them to function as a single, large network. See also *Internet*.

**Internet.** The internet administered by the Internet Architecture Board (IAB), consisting of large national backbone networks and many regional and campus networks all over the world. The Internet uses the Internet suite of protocols.

**Internet address.** See *IP address*.

**Internet Architecture Board (IAB).** The technical body that oversees the development of the Internet suite of protocols that are known as TCP/IP.

**Internet Control Message Protocol (ICMP).** The protocol used to handle errors and control messages in the Internet Protocol (IP) layer. Reports of problems and incorrect datagram destinations are returned to the original datagram source. ICMP is part of the Internet Protocol.

**Internet Control Protocol (ICP).** The Virtual NEtworking System (VINES) protocol that provides exception notifications, metric notifications, and PING support. See also *RouTing update Protocol (RTP)*.

**Internet Engineering Task Force (IETF).** The task force of the Internet Architecture Board (IAB) that is responsible for solving the short-term engineering needs of the Internet.

**Internetwork Packet Exchange (IPX).** (1) The network protocol used to connect Novell's servers, or any workstation or router that implements IPX, with other workstations. Although similar to the Internet Protocol (IP), IPX uses different packet formats and terminology. (2) See also *Xerox Network Systems (XNS)*.

**Internet Protocol (IP).** A connectionless protocol that routes data through a network or interconnected

networks. IP acts as an intermediary between the higher protocol layers and the physical network. However, this protocol does not provide error recovery and flow control and does not guarantee the reliability of the physical network.

**interoperability.** The capability to communicate, execute programs, or transfer data among various functional units in a way that requires the user to have little or no knowledge of the unique characteristics of those units. (T)

**intra-area routing.** In Internet communications, the routing of data within an area.

**Inverse Address Resolution Protocol (InARP).** In the Internet suite of protocols, the protocol used for locating a protocol address through the known hardware address. In a frame-relay context, the data link connection identifier (DLCI) is synonymous with the known hardware address.

**IPPN.** The interface that other protocols can use to transport data over IP.

**IP address.** The 32-bit address defined by the Internet Protocol, standard 5, Request for Comments (RFC) 791. It is usually represented in dotted decimal notation.

**IP datagram.** In the Internet suite of protocols, the fundamental unit of information transmitted through an internet. It contains source and destination addresses, user data, and control information such as the length of the datagram, the header checksum, and flags indicating whether the datagram can be or has been fragmented.

**IP router.** A device in an IP internet that is responsible for making decisions about the paths over which network traffic will flow. Routing protocols are used to gain information about the network and to determine the best route over which the datagram should be forwarded toward the final destination. The datagrams are routed based on IP destination addresses.

**IPXWAN.** A Novell protocol that is used to exchange router-to-router information before exchanging standard Internetwork Packet Exchange (IPX) routing information and traffic over wide area networks (WANs).

## J

**jitter.** (1) Short-term non-cumulative variations of the significant instants of a digital signal from their ideal positions in time. (2) Undesirable variations of a transmitted digital signal. (3) Variations in the network delay.

## L

**LAN bridge server (LBS).** In the IBM Token-Ring Network Bridge Program, the server that keeps statistical information about frames forwarded between two or more rings (through a bridge). The LBS sends these statistics to the appropriate LAN managers through the LAN reporting mechanism (LRM).

**LAN Network Manager (LNM).** An IBM licensed program that enables a user to manage and monitor LAN resources from a central workstation.

**LAN segment.** (1) Any portion of a LAN (for example, a bus or ring) that can operate independently, but that is connected to other parts of the network by means of bridges. (2) A ring or bus network without bridges.

**layer.** (1) In network architecture, a group of services that is complete from a conceptual point of view, that is one out of a set of hierarchically arranged groups, and that extends across all systems that conform to the network architecture. (T) (2) In the Open Systems Interconnection reference model, one of seven conceptually complete, hierarchically arranged groups of services, functions, and protocols, that extend across all open systems. (T) (3) In SNA, a grouping of related functions that are logically separate from the functions in other groups. Implementation of the functions in one layer can be changed without affecting functions in other layers.

**line switching.** Synonym for *circuit switching*.

**link.** The combination of the link connection (the transmission medium) and two link stations, one at each end of the link connection. A link connection can be shared among multiple links in a multipoint or token-ring configuration.

**link access protocol balanced (LAPB).** A protocol used for accessing an X.25 network at the link level. LAPB is a duplex, asynchronous, symmetric protocol, used in point-to-point communication.

**link-attached.** (1) Pertaining to devices that are connected to a controlling unit by a data link. (2) Contrast with *channel-attached*. (3) Synonymous with *remote*.

**link connection.** (1) The physical equipment providing two-way communication between one link station and one or more other link stations; for example, a telecommunication line and data circuit-terminating equipment (DCE). (2) In SNA, synonymous with *data circuit*.

**link level.** (1) A part of Recommendation X.25 that defines the link protocol used to get data into and out of the network across the full-duplex link connecting the subscriber's machine to the network node. LAP and

LAPB are the link access protocols recommended by the CCITT. (2) See *data link level*.

**link-state.** In routing protocols, the advertised information about the usable interfaces and reachable neighbors of a router or network. The protocol's topological database is formed from the collected link-state advertisements.

**link station.** (1) The hardware and software components within a node representing a connection to an adjacent node over a specific link. For example, if node A is the primary end of a multipoint line that connects to three adjacent nodes, node A will have three link stations representing the connections to the adjacent nodes. (2) See also *adjacent link station (ALS)*.

**local.** (1) Pertaining to a device accessed directly without use of a telecommunication line. (2) Contrast with *remote*. (3) Synonym for *channel-attached*.

**local area network (LAN).** (1) A computer network located on a user's premises within a limited geographical area. Communication within a local area network is not subject to external regulations; however, communication across the LAN boundary may be subject to some form of regulation. (T) (2) A network in which a set of devices are connected to one another for communication and that can be connected to a larger network. (3) See also *Ethernet* and *token ring*. (4) Contrast with *metropolitan area network (MAN)* and *wide area network (WAN)*.

**local bridging.** A function of a bridge program that allows a single bridge to connect multiple LAN segments without using a telecommunication link. Contrast with *remote bridging*.

**local management interface (LMI).** See *local management interface (LMI) protocol*.

**local management interface (LMI) protocol.** In NCP, a set of frame-relay network management procedures and messages used by adjacent frame-relay nodes to exchange line status information over DLCI X'00'. NCP supports both the American National Standards Institute (ANSI) and International Telegraph and Telephone Consultative Committee (ITU-T/CCITT) versions of LMI protocol. These standards refer to LMI protocol as *link integrity verification tests (LIVT)*.

**locally administered address.** In a local area network, an adapter address that the user can assign to override the universally administered address. Contrast with *universally administered address*.

**logical channel.** In packet mode operation, a sending channel and a receiving channel that together are used to send and receive data over a data link at the same time. Several logical channels can be established on the same data link by interleaving the transmission of packets.

**logical link.** A pair of link stations, one in each of two adjacent nodes, and their underlying link connection, providing a single link-layer connection between the two nodes. Multiple logical links can be distinguished while they share the use of the same physical media connecting two nodes. Examples are 802.2 logical links used on local area network (LAN) facilities and LAP E logical links on the same point-to-point physical link between two nodes. The term logical link also includes the multiple X.25 logical channels that share the use of the access link from a DTE to an X.25 network.

**logical link control (LLC).** The data link control (DLC) LAN sublayer that provides two types of DLC operation for the orderly exchange of information. The first type is connectionless service, which allows information to be sent and received without establishing a link. The LLC sublayer does not perform error recovery or flow control for connectionless service. The second type is connection-oriented service, which requires establishing a link prior to the exchange of information. Connection-oriented service provides sequenced information transfer, flow control, and error recovery.

**logical link control (LLC) protocol.** In a local area network, the protocol that governs the exchange of transmission frames between data stations independently of how the transmission medium is shared. (T) The LLC protocol was developed by the IEEE 802 committee and is common to all LAN standards.

**logical link control (LLC) protocol data unit.** A unit of information exchanged between link stations in different nodes. The LLC protocol data unit contains a destination service access point (DSAP), a source service access point (SSAP), a control field, and user data.

**logical unit (LU).** A type of network accessible unit that enables users to gain access to network resources and communicate with each other.

**loopback test.** A test in which signals from a tester are looped at a modem or other network element back to the tester for measurements that determine or verify the quality of the communications path.

**low-entry networking (LEN).** A capability of nodes to attach directly to one another using basic peer-to-peer protocols to support multiple and parallel sessions between logical units.

**low-entry networking (LEN) end node.** A LEN node receiving network services from an adjacent APPN network node.

**low-entry networking (LEN) node.** A node that provides a range of end-user services, attaches directly to other nodes using peer protocols, and derives network services implicitly from an adjacent APPN network node, that is, without the direct use of CP-CP sessions.

## M

**Management Information Base (MIB).** (1) A collection of objects that can be accessed by means of a network management protocol. (2) A definition for management information that specifies the information available from a host or gateway and the operations allowed. (3) In OSI, the conceptual repository of management information within an open system.

**management station.** In Internet communications, the system responsible for managing all, or a portion of, a network. The management station communicates with network management agents that reside in the managed node by means of a network management protocol, such as the Simple Network Management Protocol (SNMP).

**mapping.** The process of converting data that is transmitted in one format by the sender into the data format that can be accepted by the receiver.

**mask.** (1) A pattern of characters used to control retention or elimination of portions of another pattern of characters. (l) (A) (2) To use a pattern of characters to control retention or elimination of portions of another pattern of characters. (l) (A)

**maximum transmission unit (MTU).** In LANs, the largest possible unit of data that can be sent on a given physical medium in a single frame. For example, the MTU for Ethernet is 1500 bytes.

**medium access control (MAC).** In LANs, the sublayer of the data link control layer that supports medium-dependent functions and uses the services of the physical layer to provide services to the logical link control (LLC) sublayer. The MAC sublayer includes the method of determining when a device has access to the transmission medium.

**medium access control (MAC) protocol.** In a local area network, the protocol that governs access to the transmission medium, taking into account the topological aspects of the network, in order to enable the exchange of data between data stations. (T)

**medium access control (MAC) sublayer.** In a local area network, the part of the data link layer that applies a medium access method. The MAC sublayer supports topology-dependent functions and uses the services of the physical layer to provide services to the logical link control sublayer. (T)

**metric.** In Internet communications, a value, associated with a route, which is used to discriminate between multiple exit or entry points to the same autonomous system. The route with the lowest metric is preferred.

**metropolitan area network (MAN).** A network formed by the interconnection of two or more networks which

may operate at higher speed than those networks, may cross administrative boundaries, and may use multiple access methods. (T) Contrast with *local area network (LAN)* and *wide area network (WAN)*.

**MIB.** (1) MIB module. (2) Management Information Base.

**MIB object.** Synonym for *MIB variable*.

**MIB variable.** In the Simple Network Management Protocol (SNMP), a specific instance of data defined in a MIB module. Synonymous with *MIB object*.

**MIB view.** In the Simple Network Management Protocol (SNMP), the collection of managed objects, known to the agent, that is visible to a particular community.

**MILNET.** The military network that was originally part of ARPANET. It was partitioned from ARPANET in 1984. MILNET provides a reliable network service for military installations.

**modem (modulator/demodulator).** (1) A functional unit that modulates and demodulates signals. One of the functions of a modem is to enable digital data to be transmitted over analog transmission facilities. (T) (A) (2) A device that converts digital data from a computer to an analog signal that can be transmitted on a telecommunication line, and converts the analog signal received to data for the computer.

**module.** In the Nways Switch, a packaged functional hardware unit containing logic cards, connectors, and lights. The modules are used to package adapters, line interface couplers, voice server extensions, and other components. All modules are *hot pluggable* in the logic subracks.

**modulo.** (1) Pertaining to a modulus; for example, 9 is equivalent to 4 modulo 5. (2) See also *modulus*.

**modulus.** A number, such as a positive integer, in a relationship that divides the difference between two related numbers without leaving a remainder; for example, 9 and 4 have a modulus of 5 ( $9 - 4 = 5$ ;  $4 - 9 = -5$ ; and 5 divides both 5 and -5 without leaving a remainder).

**monitor.** (1) A device that observes and records selected activities within a data processing system for analysis. Possible uses are to indicate significant departure from the norm, or to determine levels of utilization of particular functional units. (T) (2) Software or hardware that observes, supervises, controls, or verifies operations of a system. (A) (3) The function required to initiate the transmission of a token on the ring and to provide soft-error recovery in case of lost tokens, circulating frames, or other difficulties. The capability is present in all ring stations.

**multicast.** (1) Transmission of the same data to a selected group of destinations. (T) (2) A special form of broadcast in which copies of a packet are delivered to only a subset of all possible destinations.

**multipath channel (MPC).** A channel protocol that uses multiple unidirectional subchannels for VTAM-to-VTAM bidirectional communication.

**multiple-domain support (MDS).** A technique for transporting management services data between management services function sets over LU-LU and CP-CP sessions. See also *multiple-domain support message unit (MDS-MU)*.

**multiple-domain support message unit (MDS-MU).** The message unit that contains management services data and flows between management services function sets over the LU-LU and CP-CP sessions used by multiple-domain support. This message unit, as well as the actual management services data that it contains, is in general data stream (GDS) format. See also *control point management services unit (CP-MSU)*, *management services unit (MSU)*, and *network management vector transport (NMVT)*.

## N

**Name Binding Protocol (NBP).** In AppleTalk networks, a protocol that provides name translation function from the AppleTalk entity (resource) name (character string) into an AppleTalk IP address (16-bit number) on the transport layer.

**name resolution.** In Internet communications, the process of mapping a machine name to the corresponding Internet Protocol (IP) address. See also *Domain Name System (DNS)*.

**name server.** In the Internet suite of protocols, synonym for *domain name server*.

**nearest active upstream neighbor (NAUN).** In the IBM Token-Ring Network, the station sending data directly to a given station on the ring.

**neighbor.** A router on a common subnetwork that has been designated by a network administrator to receive routing information.

**NetBIOS.** Network Basic Input/Output System. A standard interface to networks, IBM personal computers (PCs), and compatible PCs, that is used on LANs to provide message, print-server, and file-server functions. Application programs that use NetBIOS do not need to handle the details of LAN data link control (DLC) protocols.

**network.** (1) A configuration of data processing devices and software connected for information interchange. (2) A group of nodes and the links interconnecting them.

**Network Access Server (NAS).** A device providing temporary, on-demand network access to users. This access is point-to-point using PSTN or ISDN lines.

**network accessible unit (NAU).** A logical unit (LU), physical unit (PU), control point (CP), or system services control point (SSCP). It is the origin or the destination of information transmitted by the path control network. Synonymous with *network addressable unit*.

**network address.** According to ISO 7498-3, a name, unambiguous within the OSI environment, that identifies a set of network service access points.

**network addressable unit (NAU).** Synonym for *network accessible unit*.

**network architecture.** The logical structure and operating principles of a computer network. (T)

**Note:** The operating principles of a network include those of services, functions, and protocols.

**network congestion.** An undesirable overload condition caused by traffic in excess of what a network can handle.

**network identifier.** (1) In TCP/IP, that part of the IP address that defines a network. The length of the network ID depends on the type of network class (A, B, or C). (2) A 1- to 8-byte customer-selected name or an 8-byte IBM -registered name that uniquely identifies a specific subnetwork.

**Network Information Center (NIC).** In Internet communications, local, regional, and national groups throughout the world who provide assistance, documentation, training, and other services to users.

**network layer.** In Open Systems Interconnection (OSI) architecture, the layer that is responsible for routing, switching, and link-layer access across the OSI environment.

**network management.** The process of planning, organizing, and controlling a communication-oriented data processing or information system.

**network management station.** In the Simple Network Management Protocol (SNMP), a station that executes management application programs that monitor and control network elements.

**network management vector transport (NMVT).** A management services request/response unit (RU) that flows over an active session between physical unit management services and control point management services (SSCP-PU session).

**network manager.** A program or group of programs that is used to monitor, manage, and diagnose the problems of a network.



**network node (NN).** See *Advanced Peer-to-Peer Networking (APPN) network node*.

**network support station.** The processor used to locally operate and service the Nways Switch. It is used by the Nways Switch administrator or service personnel.

**network user address (NUA).** In X.25 communications, the X.121 address containing up to 15 binary code digits.

**node.** (1) In a network, a point at which one or more functional units connect channels or data circuits. (I)  
(2) Any device, attached to a network, that transmits and receives data.

**noncanonical address.** In LANs, a format for the transmission of medium access control (MAC) addresses for token-ring adapters. In noncanonical format, the most significant (leftmost) bit of each address byte is transmitted first. Contrast with *canonical address*.

**Non-Return-to-Zero Changes-on-Ones Recording (NRZ-1).** A recording method in which the ones are represented by a change in the condition of magnetization, and zeros are represented by the absence of change. Only the one signals are explicitly recorded. (Previously called *non-return-to-zero inverted*, NRZI, recording.)

**nonseed router.** In AppleTalk networks, a router that acquires network number range and zone list information from a seed router attached to the same network.

**Nways Switch.** Synonymous with IBM 2220 Nways BroadBand Switch.

**Nways Switch configuration station.** A dedicated OS/2 station running a stand-alone version of the Nways Switch Configuration Tool (NCT). It is used to generate a network configuration database and should be installed as a remote console.

## O

**Open Shortest Path First (OSPF).** In the Internet suite of protocols, a function that provides intradomain information transfer. An alternative to the Routing Information Protocol (RIP), OSPF allows the lowest-cost routing and handles routing in large regional or corporate networks.

**Open Systems Interconnection (OSI).** (1) The interconnection of open systems in accordance with standards of the International Organization for Standardization (ISO) for the exchange of information. (T) (A) (2) The use of standardized procedures to enable the interconnection of data processing systems.

**Note:** OSI architecture establishes a framework for coordinating the development of current and future standards for the interconnection of computer systems. Network functions are divided into seven layers. Each layer represents a group of related data processing and communication functions that can be carried out in a standard way to support different applications.

**Open Systems Interconnection (OSI) architecture.** Network architecture that adheres to that particular set of ISO standards that relates to Open Systems Interconnection. (T)

**Open Systems Interconnection (OSI) reference model.** A model that describes the general principles of the Open Systems Interconnection, as well as the purpose and the hierarchical arrangement of its seven layers. (T)

**origin.** An external logical unit (LU) or application program from which a message or other data originates. See also *destination*.

**orphan circuit.** A non-configured circuit whose availability is learned dynamically.

## P

**padding.** (1) A technique by which a receiving component controls the rate of transmission of a sending component to prevent overrun or congestion. (2) See also *flow control*, *receive pacing*, *send pacing*, *session-level pacing*, and *virtual route (VR) pacing*.

**packet.** In data communication, a sequence of binary digits, including data and control signals, that is transmitted and switched as a composite whole. The data, control signals, and, possibly, error control information are arranged in a specific format. (I)

**packet internet groper (PING).** (1) In Internet communications, a program used in TCP/IP networks to test the ability to reach destinations by sending the destinations an Internet Control Message Protocol (ICMP) echo request and waiting for a reply. (2) In communications, a test of reachability.

**packet loss ratio.** The probability that a packet will not reach its destination or not reach it within a specified time.

**packet mode operation.** Synonym for *packet switching*.

**packet switching.** (1) The process of routing and transferring data by means of addressed packets so that a channel is occupied only during transmission of a packet. On completion of the transmission, the channel is made available for transfer of other packets. (I) (2) Synonymous with *packet mode operation*. See also *circuit switching*.

**parallel bridges.** A pair of bridges connected to the same LAN segment, creating redundant paths to the segment.

**parallel transmission groups.** Multiple transmission groups between adjacent nodes, with each group having a distinct transmission group number.

**path.** (1) In a network, any route between any two nodes. A path may include more than one branch. (T) (2) The series of transport network components (path control and data link control) that are traversed by the information exchanged between two network accessible units. See also *explicit route (ER)*, *route extension*, and *virtual route (VR)*.

**path control (PC).** The function that routes message units between network accessible units in the network and provides the paths between them. It converts the basic information units (BIUs) from transmission control (possibly segmenting them) into path information units (PIUs) and exchanges basic transmission units containing one or more PIUs with data link control. Path control differs by node type: some nodes (APPN nodes, for example) use locally generated session identifiers for routing, and others (subarea nodes) use network addresses for routing.

**path cost.** In link-state routing protocols, the sum of the link costs along the path between two nodes or networks.

**path information unit (PIU).** A message unit consisting of a transmission header (TH) alone, or a TH followed by a basic information unit (BIU) or a BIU segment.

**pattern-matching character.** A special character such as an asterisk (\*) or a question mark (?) that can be used to represent one or more characters. Any character or set of characters can replace a pattern-matching character. Synonymous with *global character* and *wildcard character*.

**permanent virtual circuit (PVC).** In X.25 and frame-relay communications, a virtual circuit that has a logical channel permanently assigned to it at each data terminal equipment (DTE). Call-establishment protocols are not required. Contrast with *switched virtual circuit (SVC)*.

**physical circuit.** A circuit established without multiplexing. See also *data circuit*. Contrast with *virtual circuit*.

**physical layer.** In the Open Systems Interconnection reference model, the layer that provides the mechanical, electrical, functional, and procedural means to establish, maintain, and release physical connections over the transmission medium. (T)

**physical unit (PU).** (1) The component that manages and monitors the resources (such as attached links and

adjacent link stations) associated with a node, as requested by an SSCP via an SSCP-PU session. An SSCP activates a session with the physical unit in order to indirectly manage, through the PU, resources of the node such as attached links. This term applies to type 2.0, type 4, and type 5 nodes only. (2) See also *peripheral PU* and *subarea PU*.

**ping command.** The command that sends an Internet Control Message Protocol (ICMP) echo-request packet to a gateway, router, or host with the expectation of receiving a reply.

**Point-to-Point Protocol (PPP).** A protocol that provides a method for encapsulating and transmitting packets over serial point-to-point links.

**polling.** (1) On a multipoint connection or a point-to-point connection, the process whereby data stations are invited, one at a time, to transmit. (I) (2) Interrogation of devices for such purposes as to avoid contention, to determine operational status, or to determine readiness to send or receive data. (A)

**port.** (1) An access point for data entry or exit. (2) A connector on a device to which cables for other devices such as display stations and printers are attached. (3) The representation of a physical connection to the link hardware. A port is sometimes referred to as an adapter; however, there can be more than one port on an adapter. There may be one or more ports controlled by a single DLC process. (4) In the Internet suite of protocols, a 16-bit number used to communicate between TCP or the User Datagram Protocol (UDP) and a higher-level protocol or application. Some protocols, such as File Transfer Protocol (FTP) and Simple Mail Transfer Protocol (SMTP), use the same well-known port number in all TCP/IP implementations. (5) An abstraction used by transport protocols to distinguish among multiple destinations within a host machine. (6) Synonymous with *socket*.

**port number.** In Internet communications, the identification of an application entity to the transport service.

**private branch exchange (PBX).** A private telephone exchange for transmission of calls to and from the public telephone network.

**problem determination.** The process of determining the source of a problem; for example, a program component, machine failure, telecommunication facilities, user or contractor-installed programs or equipment, environmental failure such as a power loss, or user error.

**program temporary fix (PTF).** A temporary solution or bypass of a problem diagnosed by IBM in a current unaltered release of the program.

**protocol.** (1) A set of semantic and syntactic rules that determine the behavior of functional units in achieving

communication. (1) (2) In Open Systems Interconnection architecture, a set of semantic and syntactic rules that determine the behavior of entities in the same layer in performing communication functions. (T) (3) In SNA, the meanings of, and the sequencing rules for, requests and responses used for managing the network, transferring data, and synchronizing the states of network components. Synonymous with *line control discipline* and *link discipline*. See *bracket protocol* and *link protocol*.

**protocol data unit (PDU).** A unit of data specified in a protocol of a given layer and consisting of protocol control information of this layer, and possibly user data of this layer. (T)

**pulse code modulation (PCM).** A standard adopted for the digitalization of an analog voice signal. In PCM, the voice is sampled at a rate of eight kHz and each sample is coded in an 8-bit frame.

## R

**Rapid Transport Protocol (RTP) connection.** In high-performance routing (HPR), the connection established between the endpoints of the route to transport session traffic.

**reachability.** The ability of a node or a resource to communicate with another node or resource.

**read-only memory (ROM).** Memory in which stored data cannot be modified by the user except under special conditions.

**real-time processing.** The manipulation of data that are required, or generated, by some process while the process is in operation. Usually the results are used to influence the process, and perhaps related processes, while it is occurring.

**reassembly.** In communications, the process of putting segmented packets back together after they have been received.

**receive not ready (RNR).** In communications, a data link command or response that indicates a temporary condition of being unable to accept incoming frames.

**receive not ready (RNR) packet.** See *RNR packet*.

**received line signal detector (RLSD).** In the EIA 232 standard, a signal that indicates to the data terminal equipment (DTE) that it is receiving a signal from the remote data circuit-terminating equipment (DCE). Synonymous with *carrier detect* and *data carrier detect (DCD)*.

**Recognized Private Operating Agency (RPOA).** Any individual, company, or corporation, other than a government department or service, that operates a telecommunication service and is subject to the

obligations undertaken in the Convention of the International Telecommunication Union and in the Regulations; for example, a communication common carrier.

**reduced instruction-set computer (RISC).** A computer that uses a small, simplified set of frequently used instructions for rapid execution.

**remote.** (1) Pertaining to a system, program, or device that is accessed through a telecommunication line. (2) Synonym for *link-attached*. (3) Contrast with *local*.

**remote bridging.** The function of a bridge that allows two bridges to connect multiple LANs using a telecommunication link. Contrast with *local bridging*.

**remote console.** A station running OS/2, TCP/IP, and the remote Nways Switch Resource Control program. It can be connected to any network support station to operate and service the Nways Switch remotely.

The connection may be through:

- A switched line using a modem

Any network support station can be used as a remote console of another network support station.

**Remote Execution Protocol (REXEC).** A protocol that allows the execution of a command or program on any host in the network. The local host receives the results of the command execution.

**Request for Comments (RFC).** In Internet communications, the document series that describes a part of the Internet suite of protocols and related experiments. All Internet standards are documented as RFCs.

**reset.** On a virtual circuit, reinitialization of data flow control. At reset, all data in transit are eliminated.

**reset request packet.** In X.25 communications, a packet transmitted by the data terminal equipment (DTE) to the data circuit-terminating equipment (DCE) to request that a virtual call or a permanent virtual circuit be reset. The reason for the request can also be specified in the packet.

**resource.** In the Nways Switch, an hardware element or a logical entity created by the Control Program. For example, the adapters, LICs, and lines are physical resources. The control points and connections are logical resources.

**ring.** See *ring network*.

**ring network.** (1) A network in which every node has exactly two branches connected to it and in which there are exactly two paths between any two nodes. (T) (2) A network configuration in which devices are connected by unidirectional transmission links to form a closed path.

**ring segment.** A section of a ring that can be isolated (by unplugging connectors) from the rest of the ring. See *LAN segment*.

**rlogin (remote login).** A service, offered by Berkeley UNIX-based systems, that allows authorized users of one machine to connect to other UNIX systems across an internet and interact as if their terminals were connected directly. The rlogin software passes information about the user's environment (for example, terminal type) to the remote machine.

**RNR packet.** A packet used by a data terminal equipment (DTE) or by a data circuit-terminating equipment (DCE) to indicate a temporary inability to accept additional packets for a virtual call or permanent virtual circuit.

**root bridge.** The bridge that is the root of a spanning tree formed between other active bridges in the bridging network. The root bridge originates and transmits bridge protocol data units (BPDUs) to other active bridges to maintain the spanning tree topology. It is the bridge with the highest priority in the network.

**route.** (1) An ordered sequence of nodes and transmission groups (TGs) that represent a path from an origin node to a destination node traversed by the traffic exchanged between them. (2) The path that network traffic uses to get from source to destination.

**route bridge.** A function of an IBM bridge program that allows two bridge computers to use a telecommunication link to connect two LANs. Each bridge computer is connected directly to one of the LANs, and the telecommunication link connects the two bridge computers.

**route extension (REX).** In SNA, the path control network components, including a peripheral link, that make up the portion of a path between a subarea node and a network addressable unit (NAU) in an adjacent peripheral node. See also *explicit route (ER)*, *path*, and *virtual route (VR)*.

**Route Selection control vector (RSCV).** A control vector that describes a route within an APPN network. The RSCV consists of an ordered sequence of control vectors that identify the TGs and nodes that make up the path from an origin node to a destination node.

**router.** (1) A computer that determines the path of network traffic flow. The path selection is made from several paths based on information obtained from specific protocols, algorithms that attempt to identify the shortest or best path, and other criteria such as metrics or protocol-specific destination addresses. (2) An attaching device that connects two LAN segments, which use similar or different architectures, at the reference model network layer. (3) In OSI terminology, a function that determines a path by which an entity can be reached. (4) In TCP/IP, synonymous with *gateway*. (5) Contrast with *bridge*.

**routing.** (1) The assignment of the path by which a message is to reach its destination. (2) In SNA, the forwarding of a message unit along a particular path through a network, as determined by parameters carried in the message unit, such as the destination network address in a transmission header.

**routing domain.** In Internet communications, a group of intermediate systems that use a routing protocol so that the representation of the overall network is the same within each intermediate system. Routing domains are connected to each other by exterior links.

**Routing Information Protocol (RIP).** In the Internet suite of protocols, an interior gateway protocol used to exchange intradomain routing information and to determine optimum routes between internet hosts. RIP determines optimum routes on the basis of route metrics, not link transmission speed.

**routing loop.** A situation that occurs when routers circulate information among themselves until convergence occurs or until the networks involved are considered unreachable.

**routing protocol.** A technique used by a router to find other routers and to remain up to date about the best way to get to reachable networks.

**routing table.** A collection of routes used to direct datagram forwarding or to establish a connection. The information is passed among routers to identify network topology and destination feasibility.

**Routing Table Maintenance Protocol (RTMP).** In AppleTalk networks, a protocol that provides routing information generation and maintenance on the transport layer by means of the AppleTalk routing table. The AppleTalk routing table directs packet transmission through the internet from source socket to destination socket.

**RouTing update Protocol (RTP).** The VIRTUAL NETWORKING SYSTEM (VINES) protocol that maintains the routing database and allows the exchange of routing information between VINES nodes. See also *Internet Control Protocol (ICP)*.

**rsh.** A variant of the rlogin command that invokes a command interpreter on a remote UNIX machine and passes the command-line arguments to the command interpreter, skipping the login step completely.

## S

**SAP.** See *service access point*.

**seed router.** In AppleTalk networks, a router that maintains configuration data (network range numbers and zone lists, for example) for the network. Each network must have at least one seed router. The seed

router must be initially set up using the configurator tool. Contrast with *nonseed router*.

**segment.** (1) A section of cable between components or devices. A segment may consist of a single patch cable, several patch cables that are connected, or a combination of building cable and patch cables that are connected. (2) In Internet communications, the unit of transfer between TCP functions in different machines. Each segment contains control and data fields; the current byte-stream position and actual data bytes are identified along with a checksum to validate received data.

**segmenting.** In OSI, a function performed by a layer to map one protocol data unit (PDU) from the layer it supports into multiple PDUs.

**sequence number.** In communications, a number assigned to a particular frame or packet to control the transmission flow and receipt of data.

**Serial Line Internet Protocol (SLIP).** A protocol used over a point-to-point connection between two IP hosts over a serial line, for example, a serial cable or an RS232 connection into a modem, over a telephone line.

**server.** A functional unit that provides shared services to workstations over a network; for example, a file server, a print server, a mail server. (T)

**service access point (SAP).** (1) In Open Systems Interconnection (OSI) architecture, the point at which the services of a layer are provided by an entity of that layer to an entity of the next higher layer. (T) (2) A logical point made available by an adapter where information can be received and transmitted. A single service access point can have many links terminating in it.

**Service Advertising Protocol (SAP).** In Internetwork Packet Exchange (IPX), a protocol that provides the following:

- A mechanism that allows IPX servers on an internet to advertise their services by name and type. Servers using this protocol have their name, service type, and address recorded in all file servers running NetWare.
- A mechanism that allows a workstation to broadcast a query to discover the identities of all servers of all types, all servers of a specific type, or the nearest server of a specific type.
- A mechanism that allows a workstation to query any file server running NetWare to discover the names and addresses of all servers of a specific type.

**session.** (1) In network architecture, for the purpose of data communication between functional units, all the activities which take place during the establishment, maintenance, and release of the connection. (T) (2) A logical connection between two network accessible units (NAUs) that can be activated, tailored to provide various protocols, and deactivated, as requested. Each

session is uniquely identified in a transmission header (TH) accompanying any transmissions exchanged during the session.

**Simple Network Management Protocol (SNMP).** In the Internet suite of protocols, a network management protocol that is used to monitor routers and attached networks. SNMP is an application layer protocol. Information on devices managed is defined and stored in the application's Management Information Base (MIB).

**SNA management services (SNA/MS).** The services provided to assist in management of SNA networks.

**socket.** (1) An endpoint for communication between processes or application programs. (2) The abstraction provided by the University of California's Berkeley Software Distribution (commonly called Berkeley UNIX or BSD UNIX) that serves as an endpoint for communication between processes or applications.

**source route bridging.** In LANs, a bridging method that uses the routing information field in the IEEE 802.5 medium access control (MAC) header of a frame to determine which rings or token-ring segments the frame must transit. The routing information field is inserted into the MAC header by the source node. The information in the routing information field is derived from explorer packets generated by the source host.

**source routing.** In LANs, a method by which the sending station determines the route the frame will follow and includes the routing information with the frame. Bridges then read the routing information to determine whether they should forward the frame.

**source service access point (SSAP).** In SNA and TCP/IP, a logical address that allows a system to send data to a remote device from the appropriate communications support. Contrast with *destination service access point (DSAP)*.

**spanning tree.** In LAN contexts, the method by which bridges automatically develop a routing table and update that table in response to changing topology to ensure that there is only one route between any two LANs in the bridged network. This method prevents packet looping, where a packet returns in a circuitous route back to the sending router.

**sphere of control (SOC).** The set of control point domains served by a single management services focal point.

**sphere of control (SOC) node.** A node directly in the sphere of control of a focal point. A SOC node has exchanged management services capabilities with its focal point. An APPN end node can be a SOC node if it supports the function to exchange management services capabilities.

**split horizon.** A technique for minimizing the time to achieve network convergence. A router records the interface over which it received a particular route and does not propagate its information about the route back over the same interface.

**spoofing.** For data links, a technique in which a protocol initiated from an end station is acknowledged and processed by an intermediate node on behalf of the final destination. In IBM 6611 data link switching, for example, SNA frames are encapsulated into TCP/IP packets for transport across a non-SNA wide area network, unpacked by another IBM 6611, and passed to the final destination. A benefit of spoofing is the prevention of end-to-end session timeouts.

**standard MIB.** In the Simple Network Management Protocol (SNMP), a MIB module that is located under the management branch of the Structure of Management Information (SMI) and that is considered a standard by the Internet Engineering Task Force (IETF).

**static route.** The route between hosts, networks, or both that is manually entered into a routing table.

**station.** An input or output point of a system that uses telecommunication facilities; for example, one or more systems, computers, terminals, devices, and associated programs at a particular location that can send or receive data over a telecommunication line.

**StreetTalk.** In the Virtual NETworking System (VINES), a unique network-wide naming and addressing system that allows users to locate and access any resource on the network without knowing the network topology. See also *Internet Control Protocol (ICP)* and *RouTing update Protocol (RTP)*.

**Structure of Management Information (SMI).** (1) In the Simple Network Management Protocol (SNMP), the rules used to define the objects that can be accessed by means of a network management protocol. (2) In OSI, the set of standards relating to management information. The set includes the *Management Information Model* and the *Guidelines for the Definition of Managed Objects*

**subarea.** A portion of the SNA network consisting of a subarea node, attached peripheral nodes, and associated resources. Within a subarea node, all network accessible units (NAUs), links, and adjacent link stations (in attached peripheral or subarea nodes) that are addressable within the subarea share a common subarea address and have distinct element addresses.

**subnet.** (1) In TCP/IP, a part of a network that is identified by a portion of the IP address. (2) Synonym for *subnetwork*.

**subnet address.** In Internet communications, an extension to the basic IP addressing scheme where a portion of the host address is interpreted as the local network address.

**subnet mask.** Synonym for *address mask*.

**subnetwork.** (1) Any group of nodes that have a set of common characteristics, such as the same network ID. (2) Synonymous with *subnet*.

**Subnetwork Access Protocol (SNAP).** In LANs, a 5-byte protocol discriminator that identifies the non-IEEE standard protocol family to which a packet belongs. The SNAP value is used to differentiate between protocols that use \$AA as their service access point (SAP) value.

**subnetwork mask.** Synonym for *address mask*.

**subsystem.** A secondary or subordinate system, usually capable of operating independently of, or asynchronously with, a controlling system. (T)

**switched virtual circuit (SVC).** An X.25 circuit that is dynamically established when needed. The X.25 equivalent of a switched line. Contrast with *permanent virtual circuit (PVC)*.

**synchronous.** (1) Pertaining to two or more processes that depend upon the occurrence of specific events such as common timing signals. (T) (2) Occurring with a regular or predictable time relationship.

**Synchronous Data Link Control (SDLC).** (1) A discipline conforming to subsets of the Advanced Data Communication Control Procedures (ADCCP) of the American National Standards Institute (ANSI) and High-level Data Link Control (HDLC) of the International Organization for Standardization, for managing synchronous, code-transparent, serial-by-bit information transfer over a link connection. Transmission exchanges may be duplex or half-duplex over switched or nonswitched links. The configuration of the link connection may be point-to-point, multipoint, or loop. (I) (2) Contrast with *binary synchronous communication (BSC)*.

**synchronous optical network (SONET).** A US standard for transmitting digital information over optical interfaces. It is closely related to the synchronous digital hierarchy (SDH) recommendation.

**SYNTAX.** In the Simple Network Management Protocol (SNMP), a clause in the MIB module that defines the abstract data structure that corresponds to a managed object.

**system.** In data processing, a collection of people, machines, and methods organized to accomplish a set of specific functions. (I) (A)

**system configuration.** A process that specifies the devices and programs that form a particular data processing system.

**system services control point (SSCP).** A component within a subarea network for managing the configuration, coordinating network operator and problem determination requests, and providing directory services and other session services for users of the network. Multiple SSCPs, cooperating as peers with one another, can divide the network into domains of control, with each SSCP having a hierarchical control relationship to the physical units and logical units within its own domain.

**Systems Network Architecture (SNA).** The description of the logical structure, formats, protocols, and operational sequences for transmitting information units through, and controlling the configuration and operation of, networks. The layered structure of SNA allows the ultimate origins and destinations of information, that is, the users, to be independent of and unaffected by the specific SNA network services and facilities used for information exchange.

## T

**TCP/IP.** (1) Transmission Control Protocol/Internet Protocol. (2) A UNIX-like/Ethernet-based system-interconnect protocol originally developed by the US Department of Defense. TCP/IP facilitated ARPANET (Advanced Research Projects Agency Network), a packet-switched research network for which Layer 4 was TCP and Layer 3, IP.

**Telnet.** In the Internet suite of protocols, a protocol that provides remote terminal connection service. It allows users of one host to log on to a remote host and interact as directly attached terminal users of that host.

**threshold.** (1) In IBM bridge programs, a value set for the maximum number of frames that are not forwarded across a bridge due to errors, before a "threshold exceeded" occurrence is counted and indicated to network management programs. (2) An initial value from which a counter is decremented to 0, or a value to which a counter is incremented or decremented from an initial value.

**throughput class.** In packet switching, the speed at which data terminal equipment (DTE) packets travel through the packet switching network.

**time division multiplexing (TDM).** See *channelization*.

**time to live (TTL).** A technique used by best-effort delivery protocols to inhibit endlessly looping packets. The packet is discarded if the TTL counter reaches 0.

**timeout.** (1) An event that occurs at the end of a predetermined period of time that began at the

occurrence of another specified event. (l) (2) A time interval allotted for certain operations to occur; for example, response to polling or addressing before system operation is interrupted and must be restarted.

**token.** (1) In a local area network, the symbol of authority passed successively from one data station to another to indicate the station temporarily in control of the transmission medium. Each data station has an opportunity to acquire and use the token to control the medium. A token is a particular message or bit pattern that signifies permission to transmit. (T) (2) In LANs, a sequence of bits passed from one device to another along the transmission medium. When the token has data appended to it, it becomes a frame.

**token ring.** (1) According to IEEE 802.5, network technology that controls media access by passing a token (special packet or frame) between media-attached stations. (2) IEEE 802.5 network with a ring topology that passes tokens from one attaching ring station (node) to another. (3) See also *local area network (LAN)*.

**token-ring network.** (1) A ring network that allows unidirectional data transmission between data stations, by a token passing procedure, such that the transmitted data return to the transmitting station. (T) (2) A network that uses a ring topology, in which tokens are passed in a circuit from node to node. A node that is ready to send can capture the token and insert data for transmission.

**topology.** In communications, the physical or logical arrangement of nodes in a network, especially the relationships among nodes and the links between them.

**topology database update (TDU).** A message about a new or changed link or node that is broadcast among APPN network nodes to maintain the network topology database, which is fully replicated in each network node. A TDU contains information that identifies the following:

- The sending node
- The node and link characteristics of various resources in the network
- The sequence number of the most recent update for each of the resources described.

**trace.** (1) A record of the execution of a computer program. It exhibits the sequences in which the instructions were executed. (A) (2) For data links, a record of the frames and bytes transmitted or received.

**transceiver (transmitter-receiver).** In LANs, a physical device that connects a host interface to a local area network, such as Ethernet. Ethernet transceivers contain electronics that apply signals to the cable and that sense collisions.

**Transmission Control Protocol (TCP).** A communications protocol used in the Internet and in any

network that follows the U.S. Department of Defense standards for internetwork protocol. TCP provides a reliable host-to-host protocol between hosts in packet-switched communications networks and in interconnected systems of such networks. It uses the Internet Protocol (IP) as the underlying protocol.

**Transmission Control Protocol/Internet Protocol (TCP/IP).** A set of communications protocols that support peer-to-peer connectivity functions for both local and wide area networks.

**transmission group (TG).** (1) A connection between adjacent nodes that is identified by a transmission group number. (2) In a subarea network, a single link or a group of links between adjacent nodes. When a transmission group consists of a group of links, the links are viewed as a single logical link, and the transmission group is called a *multilink transmission group (MLTG)*. A *mixed-media multilink transmission group (MMMLTG)* is one that contains links of different medium types (for example, token-ring, switched SDLC, nonswitched SDLC, and frame-relay links). (3) In an APPN network, a single link between adjacent nodes. (4) See also *parallel transmission groups*.

**transmission header (TH).** Control information, optionally followed by a basic information unit (BIU) or a BIU segment, that is created and used by path control to route message units and to control their flow within the network. See also *path information unit*.

**transparent bridging.** In LANs, a method for tying individual local area networks together through the medium access control (MAC) level. A transparent bridge stores the tables that contain MAC addresses so that frames seen by the bridge can be forwarded to another LAN if the tables indicate to do so.

**transport layer.** In the Open Systems Interconnection reference model, the layer that provides a reliable end-to-end data transfer service. There may be relay open systems in the path. (T) See also *Open Systems Interconnection reference model*.

**trap.** In the Simple Network Management Protocol (SNMP), a message sent by a managed node (agent function) to a management station to report an exception condition.

**trunk line.** A high-speed line connecting two Nways Switches. It can be a coaxial cable, fiber cable, or radio wave, for example, and may be leased from telecommunication companies.

**T1.** In the United States, a 1.544-Mbps public access line. It is available in twenty-four 64-Kbps channels. The European version (E1) transmits 2.048 Mbps.

## U

**universally administered address.** In a local area network, the address permanently encoded in an adapter at the time of manufacture. All universally administered addresses are unique. Contrast with *locally administered address*.

**User Datagram Protocol (UDP).** In the Internet suite of protocols, a protocol that provides unreliable, connectionless datagram service. It enables an application program on one machine or process to send a datagram to an application program on another machine or process. UDP uses the Internet Protocol (IP) to deliver datagrams.

## V

**V.24.** In data communication, a specification of the CCITT that defines the list of definitions for interchange circuits between data terminal equipment (DTE) and data circuit-terminating equipment (DCE).

**V.25.** In data communication, a specification of the CCITT that defines the automatic answering equipment and parallel automatic calling equipment on the General Switched Telephone Network, including procedures for disabling of echo controlled devices for both manually and automatically established calls.

**V.34.** An ITU-T Recommendation for modem communication over standard commercially available voice-grade 33.6-Kbps (and slower) channels.

**V.35.** In data communication, a specification of the CCITT that defines the list of definitions for interchange circuits between data terminal equipment (DTE) and data circuit-terminating equipment (DCE) at various data rates.

**V.36.** In data communication, a specification of the CCITT that defines the list of definitions for interchange circuits between data terminal equipment (DTE) and data circuit-terminating equipment (DCE) at rates of 48, 56, 64, or 72 kilobits per second.

**version.** A separately licensed program that usually has significant new code or new function.

**VINES.** Virtual NETworking System.

**virtual circuit.** (1) In packet switching, the facilities provided by a network that give the appearance to the user of an actual connection. (T) See also *data circuit*. Contrast with *physical circuit*. (2) A logical connection established between two DTEs.

**virtual connection.** In frame relay, the return path of a potential connection.

**virtual link.** In Open Shortest Path First (OSPF), a point-to-point interface that connects border routers that



are separated by a non-backbone transit area. Because area routers are part of the OSPF backbone, the virtual link connects the backbone. The virtual links ensure that the OSPF backbone does not become discontinuous.

**Virtual Networking System (VINES).** The network operating system and network software from Banyan Systems, Inc. In a VINES network, virtual linking allows all devices and services to appear to be directly connected to each other, when they may actually be thousands of miles apart. See also *StreetTalk*.

**virtual route (VR).** (1) In SNA, either (a) a logical connection between two subarea nodes that is physically realized as a particular explicit route or (b) a logical connection that is contained wholly within a subarea node for intranode sessions. A virtual route between distinct subarea nodes imposes a transmission priority on the underlying explicit route, provides flow control through virtual route pacing, and provides data integrity through sequence numbering of path information units (PIUs). (2) Contrast with *explicit route (ER)*. See also *path* and *route extension (REX)*.

## W

**wide area network (WAN).** (1) A network that provides communication services to a geographic area larger than that served by a local area network or a metropolitan area network, and that may use or provide public communication facilities. (T) (2) A data communication network designed to serve an area of hundreds or thousands of miles; for example, public and private packet-switching networks, and national telephone networks. (3) Contrast with *local area network (LAN)* and *metropolitan area network (MAN)*.

**wildcard character.** Synonym for *pattern-matching character*.

## X

**X.21.** An International Telegraph and Telephone Consultative Committee (CCITT) recommendation for a general-purpose interface between data terminal equipment and data circuit-terminating equipment for synchronous operations on a public data network.

**X.25.** (1) An International Telegraph and Telephone Consultative Committee (CCITT) recommendation for the interface between data terminal equipment and packet-switched data networks. (2) See also *packet switching*.

**Xerox Network Systems (XNS).** The suite of internet protocols developed by the Xerox Corporation. Although similar to TCP/IP protocols, XNS uses different packet formats and terminology. See also *Internetwork Packet Exchange (IPX)*.

## Z

**zone.** In AppleTalk networks, a subset of nodes within an internet.

**Zone Information Protocol (ZIP).** In AppleTalk networks, a protocol that provides zone management service by maintaining a mapping of the zone names and network numbers across the internet on the session layer.

**zone information table (ZIT).** A listing of network numbers and their associated zone name mappings in the internet. This listing is maintained by each internet router in an AppleTalk internet.



---

# Index

## A

AAA--see authentication 264  
AAA attributes, remote 617  
AAA security  
    security 239  
access control rules for NAT 448  
accessing Host On-Demand Client Cache 148  
accessing the authentication configuration prompt 245  
accessing Web Server Cache 203  
accounting  
    security 239  
ACE/Sever  
    authentication 243  
activate  
    Host On-Demand Client Cache configuration  
        command 148  
    Host On-Demand Client Cache monitoring  
        command 151  
    Web Server Cache configuration command 203  
    Web Server Cache monitoring command 210  
activate-ip-precedence-filtering  
    Bandwidth Reservation configuration command 23  
add  
    DHCP server configuration commands 515  
    Host On-Demand Client Cache configuration  
        command 149  
    MAC filtering update command 56  
    TSF configuration command 563  
    voice feature configuration command 594  
    WAN Restoral configuration command 67  
    Web Server Cache configuration command 203  
add-circuit-class  
    Bandwidth Reservation configuration command 24  
add-class  
    Bandwidth Reservation configuration command 24  
add server  
    IP security configuration command 359  
add tunnel  
    IP security configuration command 363  
advisors  
    for network dispatcher 96  
AH 344  
algorithms for IP security (IPv4) 361  
algorithms for IP security (IPv6) 372  
assign  
    Bandwidth Reservation configuration command 25  
assign-circuit  
    Bandwidth Reservation configuration command 28  
asubvector format  
    add (force) response subvector 184  
attach  
    MAC filtering configuration command 52  
attributes, remote AAA 617  
authentication 239, 245  
    configuration commands 245  
    security 239  
    using SecurID 243

    authentication 239, 245 (*continued*)  
        limitations 244  
authentication configuration prompt  
    accessing 245  
authentication dynamic reconfiguration 264  
authentication header (AH) 344  
authentication server  
    ACE/Server 243  
    definition 243  
authorization  
    security 239

## B

bandwidth reservation  
    accessing configuration prompts 19  
    accessing monitoring prompts 40  
    configuration commands  
        summary 21  
    configuring 1  
    over Frame Relay 3  
    with filtering 6  
Bandwidth Reservation configuration commands  
    accessing the BRS configuration prompt 19  
    activate-ip-precedence-filtering 23  
    add-circuit-class 24  
    add-class 24  
    assign 25  
    assign-circuit 28  
    change-circuit-class 28  
    change-class 28  
    circuit 28  
    clear-block 29  
    create-super-class 30  
    deactivate-ip-precedence-filtering 30  
    deassign 30  
    deassign-circuit 30  
    default-circuit-class 30  
    default-class 31  
    del-circuit-class 31  
    del-class 31  
    disable 32  
    disable-hpr-over-ip-port-numbers 32  
    enable 32  
    enable-hpr-over-ip-port-numbers 33  
    interface 34  
    list 34  
    queue-length 37  
    sample configuration 11  
    set circuit defaults 38  
    show 38  
    summary 20  
    tag 38  
    untag 39  
    use circuit defaults 39  
Bandwidth Reservation monitoring commands  
    accessing the monitoring prompt 40  
    circuit 41

- Bandwidth Reservation monitoring commands
  - (continued)
  - clear 41
  - clear-circuit-class 41
  - counters 42
  - counters-circuit-class 42
  - interface 43
  - last 43
  - last-circuit-class 43
  - summary 40
- Bandwidth Reservation System (BRS)
  - description 1
  - Discard Eligibility (DE) 4
  - TCP/UDP Port Number Filtering 7
  - using IP Version 4 precedence bit processing 9
- Bandwidth Reservation System dynamic
  - reconfiguration 43
- BOOTP Server 492
- bridging features
  - MAC filtering 51
  - update commands 55
  - update subcommands 49
- BRS-see Bandwidth Reservation System 43

**C**

- cache request found 165
- caching 161
- calls
  - voice interface monitoring command 612
- cert-load
  - PKI monitoring command (IPv4) 379
- cert-req
  - PKI monitoring command (IPv4) 379
- cert-save
  - PKI monitoring command (IPv4) 379
- certificate
  - obtaining 358
- change
  - DHCP server configuration commands 521
  - NAT command 451
  - Network Address Translator command 451
- change-circuit-class
  - Bandwidth Reservation configuration command 28
- change-class
  - Bandwidth Reservation configuration command 28
- change server
  - IP security configuration command 359
- change tunnel
  - IP security configuration command 367
  - IP security monitoring command 381
- circuit
  - Bandwidth Reservation configuration command 28
  - Bandwidth Reservation monitoring command 41
- clear
  - Bandwidth Reservation monitoring command 41
  - Host On-Demand Client Cache monitoring command 152
  - MAC filtering monitoring command 59
  - VCRM monitoring command 584
  - WAN Restoral monitoring commands 75
  - Web Server Cache monitoring command 210

- clear-block
  - Bandwidth Reservation configuration command 29
- clear-circuit-class
  - Bandwidth Reservation monitoring command 41
- Command Response Vector 172
- commands
  - dial-in
    - interface monitoring 483
  - dial-out
    - interface configuration 482
    - interface monitoring 483
  - DIALs
    - global configuration 471
    - global monitoring 479
- compression
  - overview
    - frame relay 227
    - PPP 227
- configuration
  - accessing the authentication prompt 245
- configuration commands 357
  - authentication 245
  - default-policy
    - set 328
  - dial-out interface 482
  - DIALs 466
  - DIALs global 471
  - diffserv 399
    - delete 399
    - disable 400
    - enable 400
    - list 400
    - set 401
  - IPSec 357
    - accessing (IPv4) 362
    - accessing (IPv6) 372
    - add server 359
    - add tunnel 363
    - change server 359
    - change tunnel 367
    - delete certificate 359
    - delete private-key 360
    - delete server 360
    - delete tunnel (IPv4) 367
    - disable 368
    - enable 368
    - list 369
    - list certificates 360
    - list crl 360
    - list private-keys 360
    - list servers 360
    - set 370
- L2 tunneling
  - set 428, 433
- L2F, summary of 427, 429
- L2T
  - add 430
  - disable 427, 430
  - enable 428, 431
- L2TP
  - call 435

- configuration commands 357 *(continued)*
  - encapsulator 428, 432
  - kill 438
  - list 428, 432
  - memory 438
  - start 438
  - stop 438
  - tunnel 438
- L2TP, summary of 427, 429
- LDAP 327
  - disable 328
  - enable 328
  - set 330
- policy 309
  - add 309
  - change 324
  - copy 324
  - delete 324
  - disable 324
  - enable 324
  - list 324
  - qconfig 325
- PPTP, summary of 427, 429
- random early detection 415
  - delete 415
  - disable 416
  - enable 416
  - list 416
  - set 417
- refresh
  - set 331
- tunnel
  - add 430
- configuration concepts 587
- configuring 357
  - data compression on Frame Relay links 234
  - data compression on PPP links 232
  - dial-in interface 462
  - dial-out interface 465
  - diffserv 399
  - ECP encryption
    - for PPP 267
  - encryption 267
    - for frame relay 269
  - Internet Key Exchange 357
  - IP security (IPv6) 372
  - L2 protocols 427
  - LDAP 309
  - manual IP security (IPv4) 361
  - manual tunnel (IPv4) 370
  - manual tunnel (IPv6) 373
  - MPPE
    - for PPP 268
  - MS Point-to-Point Encryption 267
  - policies 309
  - Public Key Infrastructure 357
  - random early detection 415
  - WAN Restoral 67
- configuring and monitoring Web Server Cache 197
- counters
  - Bandwidth Reservation monitoring command 42

- counters-circuit-class
  - Bandwidth Reservation monitoring command 42
- create
  - MAC filtering configuration commands 52
- create-super-class
  - Bandwidth Reservation configuration command 30

## D

- data compression
  - basics 228
  - compression sessions
    - definition of 231
  - concepts 227
  - considerations 230
    - CPU load 230
    - data content 232
    - link layer compression 232
    - memory usage 231
  - data dictionary
    - definition of 228
  - history
    - definition of 228
  - on Frame Relay links 234
    - configuring 234
    - monitoring 236
  - overview 227
- deactivate-ip-precedence-filtering
  - Bandwidth Reservation configuration command 30
- deassign
  - Bandwidth Reservation configuration command 30
- deassign-circuit
  - Bandwidth Reservation configuration command 30
- default
  - MAC filtering configuration command 52
- default-circuit-class
  - Bandwidth Reservation configuration command 30
- default-class
  - Bandwidth Reservation configuration command 31
- defining a cluster
  - Host On-Demand Client Cache 111
- del-circuit-class
  - Bandwidth Reservation configuration command 31
- del-class
  - Bandwidth Reservation configuration command 31
- delete
  - DHCP server configuration commands 525
  - Host On-Demand Client Cache configuration command 149
  - Host On-Demand Client Cache monitoring command 152
  - IP security monitoring command 377
  - MAC filtering configuration command 53
  - MAC filtering update command 57
  - NAT command 452
  - Network Address Translator command 452
  - TSF configuration command 570
  - voice feature configuration command 594
  - Web Server Cache configuration command 204
  - Web Server Cache monitoring command 211

- delete certificate
  - IP security configuration command 359
- delete-file
  - TSF monitoring command 575
- delete private-key
  - IP security configuration command 360
- delete server
  - IP security configuration command 360
- delete tunnel
  - IP security configuration command (IPv4) 367
  - IP security monitoring command 382
- dependency table 169
- detach
  - MAC filtering configuration command 53
- DHCP dynamic reconfiguration 547
- DHCP server 489, 515
  - BOOTP Servers 492
  - client movement 491
  - concepts 493
  - DHCP operation 489
  - DHCP server, multiple 492
  - DHCP server, single 491
  - DHCP server and lease parameters 496
  - introduction 489
  - lease renewals 490
  - lease times 493
  - number of DHCP servers 491
  - options
    - application and service parameter 502
    - base, provided to the client 498
    - DHCP extensions 504
    - formats 496
    - IBM-specific 507
    - IP layer parameters per host 500
    - IP layer parameters per interface 501
    - link layer parameters per interface 501
    - TCP parameters 502
    - vendor 507
  - sample configuration 509
  - server options, changing 491
  - special DHCP clients 492
  - terminology 493
- DHCP server configuration commands
  - add 515
  - change 521
  - delete 525
  - disable 529
  - enable 529
  - list 529, 544
  - set 536
- DHCP Server configuration commands
  - accessing 515
- DHCP server monitoring commands
  - accessing 543
  - disable 544
  - enable 544
  - request 545
  - reset 545
- dial circuit
  - parameter defaults
    - for dial-in interfaces 463
- dial-in
  - interface monitoring commands 483
- dial-in access server
  - IP address assignment methods 467
  - server provided IP addresses 466
- dial-in interface
  - adding 464
  - configuring 462
- dial-in interfaces
  - dial circuit parameter defaults 463
  - PPP encapsulator parameter defaults 463
- dial-on-overview 63
- dial-out
  - interface configuration commands 482
  - interface monitoring commands 483
- dial-out dynamic reconfiguration 487
- dial-out interface
  - configuring 465
  - modem pools 465
- DIALs
  - configuration commands 466
  - definition 461
  - dial-in interface
    - configuring 462
  - dial-out interface
    - configuring 465
  - dynamic domain name server (DDNS)
    - description 468
  - dynamic host configuration protocol (DHCP)
    - basic setup 467
    - description 467
    - multiple hops to server 468
    - multiple server network 468
  - global configuration commands 471
  - global monitoring commands 479
  - modem pools
    - configuring 465
  - requirements 462
  - using 461
- dials command 471
- DIALs dynamic reconfiguration 484
- DIALS monitoring commands
  - accessing 479
- differentiated services dynamic reconfiguration 410
- diffserv
  - configuration commands
    - delete 399
    - disable 400
    - enable 400
    - list 400
    - set 401
    - summary 399
  - configuration prompt
    - accessing 399
  - configuring 397, 399
  - feature, summary 391
  - monitoring commands 404
    - clear 404
    - dscache 404
    - list 405

- diffserv (*continued*)
  - monitoring prompt
    - accessing 403
  - overview 391
  - terminology 396
- DiffServ--see differentiated services 410
- disable
  - Bandwidth Reservation configuration command 32
  - DHCP server configuration commands 529
  - DHCP server monitoring commands 544
  - Host On-Demand Client Cache monitoring command 153
  - IP security configuration command 368
  - IP security monitoring command 382
  - MAC filtering configuration command 53
  - MAC filtering monitoring command 59
  - NAT command 453
  - Network Address Translator command 453
  - WAN Restoral configuration command 68, 75
  - Web Server Cache monitoring command 212
- disable-hpr-over-ip-port-numbers
  - Bandwidth Reservation configuration command 32
- DLSw
  - MAC filtering 47
- dynamic domain name server (DDNS)
  - description 468
- dynamic host configuration protocol (DHCP)
  - basic setup 467
  - description 467
  - multiple hops to server 468
  - multiple server network 468
- dynamic reconfiguration 84
  - authentication 264
  - Bandwidth Reservation System 43
  - DHCP 547
  - dial-out 487
  - DIALs 484
  - differentiated services 410
  - encoding subsystem 225
  - Host On-Demand Client Cache (HOD) 155
  - IPSec 387
  - L2 tunneling 441
  - MAC filtering 61
  - NAT 459
  - network dispatcher 140
  - policy feature 337
  - TSF 580
  - voice feature 616
  - voice interfaces 616
  - Web Server Cache 215

## E

- ECP encryption
  - configuring
    - for PPP 267
- enable
  - Bandwidth Reservation configuration command 32
  - DHCP server configuration commands 529
  - DHCP server monitoring commands 544

- enable (*continued*)
  - Host On-Demand Client Cache monitoring command 152
  - IP security configuration command 368
  - IP security monitoring command 383
  - MAC filtering configuration command 54
  - MAC filtering monitoring command 60
  - NAT configuration command 453
  - Network Address Translator configuration command 453
  - WAN Restoral configuration command 69
  - WAN Restoral monitoring command 76
  - Web Server Cache monitoring command 211
- enable-hpr-over-ip-port-numbers
  - Bandwidth Reservation configuration command 33
- encapsulating security payload (ESP) 344
- encoding subsystem
  - configuring 219
  - monitoring 219, 221
- encoding subsystem dynamic reconfiguration 225
- encryption
  - configuring 267
    - for frame relay 269
  - configuring ECP
    - for PPP 267
  - configuring MPPE
    - for PPP 268
  - frame relay 267
  - monitoring
    - for frame relay 270
    - for PPP 268
  - monitoring MPPE
    - for PPP 269
  - PPP 267
- Encryption Control Protocol
  - for PPP 267
- encryption keys 357
  - for IP security (IPv4), configuring 362
- ES
  - configuring 219
  - monitoring 219
- ES--see encoding subsystem 225
- ESP 344
- executor
  - for network dispatcher 96
- External Cache Control Manager
  - adding an object 170
  - deleting an object 171
  - descriptions 170
  - disabling/enabling a partition 171
  - purging the partition 171
  - querying the object 171
  - using a URL mask 172
  - using policies 171
  - using statistics 171
  - using the dependency table 171
- External Cache Control Manager authentication 169
- External Cache Control Manager overview 168
- External Cache Control Protocol 170
  - configuration 170

External Cache Control Protocol (ECCP) Vector  
Formats 172  
  authentication request vector 173  
  authentication response vector 174  
  command request vector 173  
  command response vector 175  
  field descriptions 172  
  subvector formats 175

## F

feature command 563  
features  
  Bandwidth reservation 1  
  MAC filtering 47, 51  
  monitoring 19  
  Thin Server Feature (TSF) 551  
filtering  
  and bandwidth reservation 6  
  MAC addressing 7  
  multicast addressing 7  
  order of precedence 11  
flush  
  TSF monitoring command 575  
Frame Relay  
  Bandwidth Reservation 3  
  encryption 267  
    configuring 269  
    monitoring 270  
Frame Relay links  
  configuring and monitoring data compression 234

## G

global configuration commands  
  DIALs 471  
global monitoring commands  
  DIALs 479

## H

HOD-See Host On-Demand Client Cache 155  
Host On-Demand Client Cache  
  configuring and monitoring 143  
  defining a cluster 111  
Host On-Demand Client Cache (HOD) dynamic  
  reconfiguration 155  
Host On-Demand Client Cache configuration commands  
  activate 148  
  add 149  
  delete 149  
  list 149  
  modify 150  
Host On-Demand Client Cache modify commands  
  modify 155  
Host On-Demand Client Cache monitoring commands  
  activate 151  
  clear 152  
  delete 152  
  disable 153  
  enable 152

Host On-Demand Client Cache monitoring commands  
(*continued*)  
  list 153

## I

IBM 9783  
  communicating with the 589  
  network configurations without 592  
interface  
  Bandwidth Reservation configuration command 34  
  Bandwidth Reservation monitoring command 43  
interface configuration commands  
  dial-out 482  
interface monitoring commands  
  dial-in 483  
  dial-out 483  
Internet Key Exchange 350  
  configuring 357  
  configuring Public Key Infrastructure 353  
  key exchange phases 351  
  message exchanges 351  
  monitoring commands  
    accessing (IPv4) 376  
    monitoring commands (IPv4) 377  
IP security 341  
  algorithms (IPv6) 372  
  and L2TP packets 347  
  authentication header (AH) 344  
  certificate  
    obtaining 358  
  concepts 341  
  configuration commands  
    accessing (IPv4) 362  
    accessing (IPv6) 372  
    add server 359  
    add tunnel 363  
    change server 359  
    change tunnel 367  
    delete 359  
    delete private-key 360  
    delete server 360  
    delete tunnel 367  
    disable 368  
    enable 368  
    list 369  
    list certificates 360  
    list cri 360  
    list private-keys 360  
    list servers 360  
    set 370  
  configuring (IPv6) 372  
  configuring algorithms (IPv4) 361  
  configuring algorithms (IPv6) 372  
  configuring and monitoring 357  
  configuring encryption keys (IPv4) 362  
  configuring keys (IPv6) 372  
  encapsulating security payload (ESP) 344  
  Internet Key Exchange 350, 353  
    configuring 357  
    monitoring commands (IPv4) 377



- IP security 341 (*continued*)
  - manual
    - configuring (IPv4) 361
    - monitoring (IPv4) 387
  - manual (IPv4) 356
  - manual (IPv6) 356
  - manual tunnel
    - configuring (IPv4) 370
    - configuring (IPv6) 373
  - monitoring (IPv4) 376
  - monitoring (IPv6) 387
  - monitoring commands
    - accessing (IPv4) 381
    - accessing (IPv6) 387
    - change tunnel 381
    - delete 377
    - delete tunnel 382
    - disable 382
    - enable 383
    - itp 383
    - list 377, 383
    - reset 385
    - set 386
    - stats 378, 386
  - monitoring commands (IPv4) 381
  - monitoring commands (IPv6) 387
  - monitoring Internet Key Exchange (IPv4) 376
  - negotiated 350
    - message exchanges 351
  - nesting protocols 347
  - overview 341
  - path MTU discovery 348
  - preparing for negotiated IP security operations 357
  - Public Key Infrastructure 352
    - configuration commands 358
    - configuring 357
    - monitoring commands 378
  - secure tunnels 341
  - security association (SA) 345
  - terminology 342
  - transport mode 345
  - tunnel
    - network diagram 349
    - tunnel-in-tunnel 348
    - tunnel mode 345
    - using 341
      - AH and ESP 345
- IP security--see IPSec 387
- IPSec dynamic reconfiguration 387
- itp
  - IP security monitoring command 383

## K

- keys 357
  - for IP security (IPv4), configuring 362
  - for IP security (IPv6), configuring 372
- keywords 618

## L

- L2 tunneling dynamic reconfiguration 441

- L2F
  - configuring 427
- L2T 419, 427
  - configuration commands
    - add 430
    - disable 427, 430
    - enable 428, 431
    - encapsulator 428, 432
    - list 428, 432
    - set 428, 433
    - summary 427, 429
  - configuring 422
  - considerations
    - LCP 422
    - timing 422
  - features supported 420
  - overview 419
  - terminology 420

## L2TP

- configuring 427
- monitoring commands 435
  - call 435
  - kill 438
  - memory 438
  - start 438
  - stop 438
  - tunnel 438

## L2TP packets

- and IP security 347

## last

- Bandwidth Reservation monitoring command 43

## last-circuit-class

- Bandwidth Reservation monitoring command 43

## LDAP

- configuration commands
  - disable 328
  - enable 328
  - set 330
  - set default-policy 328
  - set refresh 331
  - summary 327
- configuring 309

## list

- Bandwidth Reservation configuration command 34
- DHCP server configuration commands 529, 544
- encoding subsystem parameters (talk 5) 222
- encoding subsystem parameters (talk 6) 220
- Host On-Demand Client Cache configuration command 149
- Host On-Demand Client Cache monitoring command 153
- IP security configuration command 369
- IP security monitoring command 377, 383
- MAC filtering configuration command 54
- MAC filtering monitoring command 60
- MAC filtering update command 57
- NAT configuration command 453
- NAT monitoring command 458
- Network Address Translator configuration command 453

- list *(continued)*
  - Network Address Translator monitoring command 458
  - TSF configuration command 570
  - TSF monitoring command 576
  - voice configuration command 600
  - voice feature configuration command 595
  - WAN Restoral configuration command 70
  - WAN Restoral monitoring command 79
  - Web Server Cache configuration command 205
  - Web Server Cache monitoring command 212
- list certificate
  - PKI monitoring command (IPv4) 380
- list certificates
  - IP security configuration command 360
- list configured-servers
  - PKI monitoring command (IPv4) 380
- list crl
  - IP security configuration command 360
- list private-keys
  - IP security configuration command 360
- list servers
  - IP security configuration command 360
- load balancing
  - with network dispatcher 96
- load certificate
  - PKI monitoring command (IPv4) 380

## M

- MAC filtering
  - accessing the configuration prompt 51
  - accessing the monitoring prompt 58
  - configuring 51
  - discussion 47
  - for DLSw traffic 47
  - parameters 47
  - update subcommands 49
  - using tags 49
- MAC filtering configuration commands
  - accessing 51
  - attach 52
  - create 52
  - default 52
  - delete 53
  - detach 53
  - disable 53
  - enable 54
  - list 54
  - move 54
  - reinit 55
  - set-cache 55
  - Set-cache 55
  - summary 51
  - update 55
  - update commands
    - add 56
    - delete 57
    - list 57
    - move 58
    - set-action 58

- MAC filtering configuration commands *(continued)*
  - update commands *(continued)*
    - summary 55
    - update subcommands 49
- MAC filtering dynamic reconfiguration 61
- MAC filtering monitoring commands
  - accessing 58
  - clear 59
  - disable 59
  - enable 60
  - list 60
  - reinit 60
  - summary 59
- manager
  - for network dispatcher 96
- manual IP security 357
  - configuration commands (IPv4) 362
  - IPv4 356
  - IPv6 356
  - monitoring (IPv6) 387
- map
  - NAT configuration command 454
  - Network Address Translator configuration command 454
- modem pools
  - configuring 465
- modify
  - Host On-Demand Client Cache configuration command 150
  - Host On-Demand Client Cache modify command 155
  - TSF configuration command 571
  - voice feature configuration command 595
  - Web Server Cache configuration command 206
  - Web Server Cache modify command 215
- monitoring 357
  - data compression on Frame Relay links 234
  - data compression on PPP links 232
  - encryption
    - for frame relay 270
    - for PPP 268
  - IP security (IPv4) 376
  - manual IP security (IPv6) 387
  - MPPE
    - for PPP 269
  - TSF monitoring commands 575
  - voice monitoring commands 612
- monitoring commands
  - dial-in interface 483
  - dial-out interface 483
  - DIALs global 479
  - diffserv
    - clear 404
    - dscache 404
    - list 405
  - IPSec 357
    - change tunnel 381
    - delete 377
    - delete tunnel 382
    - disable 382
    - enable 383

- monitoring commands *(continued)*
    - IKE, accessing (IPv4) 376
    - IPSec, accessing (IPv4) 381
    - IPSec, accessing (IPv6) 387
    - itp 383
    - list 377, 383
    - PKI, accessing (IPv4) 378
    - reset 385
    - set 386
    - stats 378, 386
  - policy
    - cache-ldap-plcys 332
    - check-consistency 333
    - disable 334
    - enable 334
    - flush-cache 334
    - list 335
    - reset 334
    - search 335
    - status 335
    - test 336
  - RED
    - clear 418
    - list 418
  - move
    - MAC filtering configuration command 54
    - MAC filtering update command 58
  - MPPE
    - configuring 267
    - for PPP 268
  - MS Point-to-Point Encryption
    - configuring 267
    - for PPP 268
- ## N
- NAPT
    - using 446
  - NAT
    - access control rules 448
    - configuring 451
    - dynamic reconfiguration 459
    - monitoring commands 458
    - packet filters 448
    - sample configuration 448
    - static address mappings 447
    - using 445
  - NAT commands
    - change 451
    - delete 452
    - disable 453
    - enable 453
    - list 453
    - map 454
    - reserve 455
    - reset 456
    - set 456
  - NAT configuration commands 451
  - negotiated IP security 350 *(continued)*
    - IKE key exchange phases 351
    - IKE message exchanges 351
    - negotiated IP security 350 *(continued)*
      - message exchanges 351
      - operations
        - preparing for 357
  - Network Address Port Translator (NAPT)
    - using 446
  - Network Address Translator
    - configuring 451
    - monitoring commands 458
  - Network Address Translator - see NAT 459
  - Network Address Translator (NAT)
    - using 445
  - Network Address Translator commands
    - change 451
    - delete 452
    - disable 453
    - enable 453
    - map 454
    - reserve 455
    - reset 456
    - set 456
  - Network Address Translator configuration
    - commands 451
    - list 453
  - Network Control Protocols (NCP)
    - for PPP interfaces
      - Encryption Control Protocol 267
  - network diagram
    - IP security tunnel 349
  - network dispatcher 95
    - advisors 96
    - configuration command 95
      - accessing 113
      - add 113
      - clear 120
      - disable 120
      - enable 121
      - list 123
      - remove 124
      - set 126
      - summary of 113
    - configuring 99
    - configuring command 113
      - accessing 131
      - list 132
      - quiesce 133
      - report 134
      - status 136
      - summary of 132
    - executor 96
    - high availability 97
    - load balancing 96
    - manager 96
    - overview 95
    - SNMP management applications 96
    - using 95
      - steps 101
  - network dispatcher dynamic reconfiguration 140
  - network dispatcher with Web Server Cache and cache hit 161

- network dispatcher with Web Server Cache and no cache hit 160
- network dispatcher without Web Server Cache 159
- Network Station 551
- NSF
  - using TFTP 554

## O

- overview
  - of compression 227
  - WAN Reroute 63
  - WAN Restoral 63

## P

- packet filters for NAT 448
- parameters
  - MAC filtering 47
- path MTU discovery 348
- Point-to-Point Protocol (PPP)
  - encryption Control Protocol 267
- policy
  - configuration commands
    - add 309
    - change 324
    - copy 324
    - delete 324
    - disable 324
    - enable 324
    - list 324
    - qconfig 325
    - summary 309
  - configuration examples 283
  - configuration prompt
    - accessing 309
  - configuring 309
  - decision and enforcement 271
  - decision and packet flow 272
  - drop all public traffic 295
  - feature, summary 271
  - generating rules 282
  - IKE decisions 273
  - IP queries 272
  - IPSec/ISAKMP only policy 293
  - IPSec/ISAKMP policy with QoS 283
  - IPSec queries 273
  - LDAP and policy database interaction 278
  - LDAP policy search engine
    - configuring and enabling 298
  - monitoring commands 332
    - cache-ldap-plcys 332
    - check-consistency 333
    - disable 334
    - enable 334
    - flush-cache 334
    - list 335
    - reset 334
    - search 335
    - status 335
    - test 336

- policy (*continued*)
  - monitoring prompt
    - accessing 332
  - objects 273
    - predefined 302
  - overview 271
  - RSVP decisions 273
  - schema 280
- policy dynamic reconfiguration 337
- PPP encapsulator
  - parameter defaults
    - for dial-in interfaces 463
- PPP links
  - configuring and monitoring data compression 232
- PPTP
  - configuring 427
- predefined policy objects 302
  - DiffServ actions 303
  - IPSec actions 303
  - IPSec proposals for IKE Phase 2 304
  - IPSec transforms 305
  - ISAKMP actions 306
  - ISAKMP proposals 306
  - validity periods 303
- preparing for negotiated IP security operations 357
- priority queuing
  - description 5
- Public Key Infrastructure 352
  - accessing the environment (IPv4) 378
  - configuration commands 358, 359
    - add server 359
    - change server 359
    - delete certificate 359
    - delete private-key 360
    - delete server 360
    - list certificates 360
    - list crl 360
    - list private-keys 360
    - list servers 360
  - configuring 353, 357
  - configuring Public Key Infrastructure 353
  - monitoring commands 378
    - accessing (IPv4) 378
    - cert-load (IPv4) 379
    - cert-req (IPv4) 379
    - cert-save (IPv4) 379
    - list certificate (IPv4) 380
    - list configured-servers (IPv4) 380
    - load certificate (IPv4) 380

## Q

- queue
  - VCRM monitoring command 584
- queue-length
  - Bandwidth Reservation configuration command 37
- quick config, example 300

## R

- radius 617

- random early detection
  - configuration commands
    - delete 415
    - disable 416
    - enable 416
    - list 416
    - set 417
    - summary 415
  - configuration prompt
    - accessing 415
  - configuring 415
  - feature, summary 413
  - monitoring prompt
    - accessing 417
  - using 413
- RED
  - monitoring commands 417
    - clear 418
    - list 418
- refresh
  - TSF monitoring command 579
- reinit
  - MAC filtering configuration command 55
  - MAC filtering monitoring command 60
- remote AAA attributes 617
  - keywords 618
  - radius 617
  - TACACS 621
- remove
  - WAN Restoral configuration command 71
- request
  - DHCP server monitoring commands 545
- request forwarded to backend server 166
- request forwarded to the responsible cache 166
- request forwarded to the responsible cache and not found 167
- requirements
  - for dial-in-access server 462
- reserve
  - NAT command 455
  - Network Address Translator command 455
- reset
  - DHCP server monitoring commands 545
  - IP security monitoring command 385
  - NAT configuration command 456, 459
  - Network Address Translator configuration 459
  - Network Address Translator configuration command 456
  - TSF monitoring command 579
- restart
  - TSF monitoring command 579
- return codes 194
  - return code and descriptions 194

## S

- Scalable High Availability Cache 164
- secure tunnels 341
- SecurID
  - description 243
  - limitations 244

- security 170
  - accounting 239
  - authentication 239
  - authorization 239
- security association (SA) 345
- server
  - ACE/Server
    - limitations 244
    - support 243
  - authentication
    - definition 243
  - DIALs
    - configuration commands 466
    - definition 461
    - requirements 462
    - using 461
- set
  - DHCP server configuration commands 536
  - encoding subsystem parameters 220
  - IP security configuration command 370
  - IP security monitoring command 386
  - NAT configuration command 456
  - Network Address Translator configuration command 456
  - TSF configuration command 572
  - TSF monitoring command 580
  - voice configuration command 601
  - voice feature configuration command 595
  - WAN Reroute configuration command 72, 77
- set-action
  - MAC filtering update command 58
- set circuit defaults
  - Bandwidth Reservation configuration command 38
- show
  - Bandwidth Reservation configuration command 38
- static address mappings 447
- stats
  - IP security monitoring command 378, 386
- status
  - voice interface monitoring command 614
- subfield format
  - dependency subfield 193
  - name subfield 193
  - object subfield 193
  - password request subfield 194
  - URL request subfield 194
- subfield formats 192
- subvector format
  - policy response subvector 186
- subvector format 176
  - add object response subvector 184
  - delete object response subvector 184
  - dependency response subvector 184
  - disable response subvector 186
  - enable response subvector 186
  - policy command subvector 179
  - purge command subvector 182
  - purge response subvector 189
  - query command subvector 182
  - query response subvector 189
  - statics command subvector 183

- subvector format 176 *(continued)*
  - URL mask command subvector 183
  - URL mask response subvector 192
- subvector formats
  - add (force) object command subvector 177
  - add object command subvector 177
  - delete object command subvector 177
  - dependency command subvector 178
  - disable command subvector 179
  - enable command subvector 179

## T

- TACACS 621
- tag
  - Bandwidth Reservation configuration command 38
- talk
  - OPCON command 471, 479, 563, 574
- Talk
  - OPCON command 515, 543, 593, 605
- thin server feature--see TSF 580
- thin server function
  - configuring 563
- TN3270E Server 143
- trace
  - voice interface monitoring command 616
- translate
  - NAT configuration command 457
  - Network Address Translator configuration command 457
- transport mode 345
- tsf
  - configuring 563
- TSF
  - configuration steps 556
  - configuring BootP/DHCP Server 557
  - configuring the server for TSF 557
  - file cache updates 555
  - overview 551
  - sample configuration 558
  - using 551
  - using RFS 554
  - using TFTP 554
- tsf configuration commands
  - summary 563
- TSF configuration commands
  - add 563
  - delete 570
  - list 570
  - modify 571
  - set 572
- TSF dynamic reconfiguration 580
- TSF monitoring commands
  - accessing 574
  - delete-file 575
  - file 576
  - flush 575
  - refresh 579
  - reset 579
  - restart 579
  - set 580

- TSF monitoring commands *(continued)*
  - summary of 575
- tunnel-in-tunnel for IP security 348
- tunnel mode 345

## U

- untag
  - Bandwidth Reservation configuration command 39
- update
  - MAC filtering configuration command 55
- update subcommands
  - MAC Filtering configuration command 49
- use circuit defaults
  - Bandwidth Reservation configuration command 39
- using
  - dial-in access server 461
  - using the HTTP Proxy 163
  - using the WAN Restoral feature 63
  - using Web Server Cache 159

## V

- VCRM
  - configuring and monitoring 583
- VCRM monitoring command
  - clear 584
  - queue 584
- VCRM monitoring environment
  - accessing 583
- Virtual Circuit Resource Manager (VCRM)
  - configuring and monitoring 583
- VoFr commands
  - add 605
  - delete 608
  - disable 608
  - enable 608
  - list 608
  - modify 610
  - reorder-call-rule 611
  - set 611
- VoFR commands 604
- VoFR configuration command summary 605
- vofr configuration commands
  - accessing 599
- voice
  - voice feature commands, summary 593
- voice adapter overview 587
- voice configuration commands
  - list 600
  - set 601
- voice feature
  - configuring 593
  - dynamic reconfiguration 616
  - using 587
- voice feature commands
  - accessing 593
- voice feature configuration commands
  - add 594
  - delete 594
  - list 595
  - modify 595

- voice feature configuration commands *(continued)*
  - set 595
- voice features 587
- voice interface configuration commands
  - accessing 600
- voice interface monitoring commands
  - accessing 612
  - calls 612
  - status 614
  - summary of 612
  - trace 616
- voice interfaces
  - dynamic reconfiguration 616
- voice over frame relay (VOFR) 25
- voice over frame relay configuration information 588

- Web Server Cache monitoring commands *(continued)*
  - clear 210
  - delete 211
  - disable 212
  - enable 211
  - list 212
- Web Server Cache overview 159
- Web Server Caching
  - defining a cluster 110
- WRS--see WAN restoral 84

## W

- WAN Reroute
  - assigning the alternate link 92
  - configuring 89
  - configuring dial circuits 91
  - configuring Frame Relay 90
  - configuring ISDN 91
  - configuring the alternate link 92
  - discussion 87
  - overview 63
  - sample configuration 89
- WAN Reroute configuration commands
  - set 72, 77
- WAN Restoral
  - configuration procedure 65
  - overview 63
  - secondary dial circuit configuration 66
- WAN restoral and WAN reroute 84
- WAN Restoral configuration commands
  - add 67
  - disable 68
  - enable 69
  - list 70
  - remove 71
  - summary 67
- WAN restoral dynamic reconfiguration 84
- WAN Restoral monitoring commands
  - accessing 74
  - clear 75
  - disable 75
  - enable 76
  - list 79
  - summary 74
- Web Server Cache Commands 203
- Web Server Cache configuration commands
  - activate 203
  - add 203
  - delete 204
  - list 205
  - modify 206
- Web Server Cache dynamic reconfiguration 215
- Web Server Cache modify commands
  - modify 215
- Web Server Cache monitoring commands
  - activate 210





---

# Readers' Comments — We'd Like to Hear from You

Access Integration Services  
Using and Configuring Features  
Version 3.4

Publication No. SC30-3989-02

Overall, how satisfied are you with the information in this book?

	Very Satisfied	Satisfied	Neutral	Dissatisfied	Very Dissatisfied
Overall satisfaction	<input type="checkbox"/>	<input type="checkbox"/>	<input type="checkbox"/>	<input type="checkbox"/>	<input type="checkbox"/>

How satisfied are you that the information in this book is:

	Very Satisfied	Satisfied	Neutral	Dissatisfied	Very Dissatisfied
Accurate	<input type="checkbox"/>	<input type="checkbox"/>	<input type="checkbox"/>	<input type="checkbox"/>	<input type="checkbox"/>
Complete	<input type="checkbox"/>	<input type="checkbox"/>	<input type="checkbox"/>	<input type="checkbox"/>	<input type="checkbox"/>
Easy to find	<input type="checkbox"/>	<input type="checkbox"/>	<input type="checkbox"/>	<input type="checkbox"/>	<input type="checkbox"/>
Easy to understand	<input type="checkbox"/>	<input type="checkbox"/>	<input type="checkbox"/>	<input type="checkbox"/>	<input type="checkbox"/>
Well organized	<input type="checkbox"/>	<input type="checkbox"/>	<input type="checkbox"/>	<input type="checkbox"/>	<input type="checkbox"/>
Applicable to your tasks	<input type="checkbox"/>	<input type="checkbox"/>	<input type="checkbox"/>	<input type="checkbox"/>	<input type="checkbox"/>

Please tell us how we can improve this book:

Thank you for your responses. May we contact you?  Yes  No

When you send comments to IBM, you grant IBM a nonexclusive right to use or distribute your comments in any way it believes appropriate without incurring any obligation to you.

---

Name

---

Address

---

Company or Organization

---

Phone No.



Fold and Tape

Please do not staple

Fold and Tape



NO POSTAGE  
NECESSARY  
IF MAILED IN THE  
UNITED STATES

# BUSINESS REPLY MAIL

FIRST-CLASS MAIL PERMIT NO. 40 ARMONK, NEW YORK

POSTAGE WILL BE PAID BY ADDRESSEE

IBM Corporation  
Design & Information Development  
Department CGF/Bldg. 656  
PO Box 12195  
Research Triangle Park, NC  
27709-9990



Fold and Tape

Please do not staple

Fold and Tape





Printed in the United States of America  
on recycled paper containing 10%  
recovered post-consumer fiber.

SC30-3989-02



Spine information:



Access Integration Services

AIS V3.4 Using Features